

P170TXE E PLUS IVECO

NUEVO

DISPONIBLE



ESPECIFICACIONES DEL PRODUCTO

Plataforma P 170 TXE E-PLUS

Altura máxima: 16,9m

Deslocamento horizontal máximo de 11,8m

Capacidade do cesto 250 kg

Possibilidade de cesto em alumínio, ou cesto de fibra isolado a 1000V.

Chassi IVECO (PB 3500kg)

INFORMACIÓN DEL PRODUCTO

Información del lugar

PALFINGER PORTUGAL, 2135-169 - Portugal 

Vendedor

Palfinger portugal

Disponibile

Disponibile

Disponibile en

20.12.2024

Tipo de Producto

Nuevo

Email

comercial@palfinger.pt

Teléfonos de Contacto

00351263650990

P 170 TXE-E SMART PLUS

**MAXIMUM PERFORMANCE
OFFERED BY LATERAL
OUTREACH AND SMALL
STABILISATION FOOTPRINT**

LIFETIME EXCELLENCE

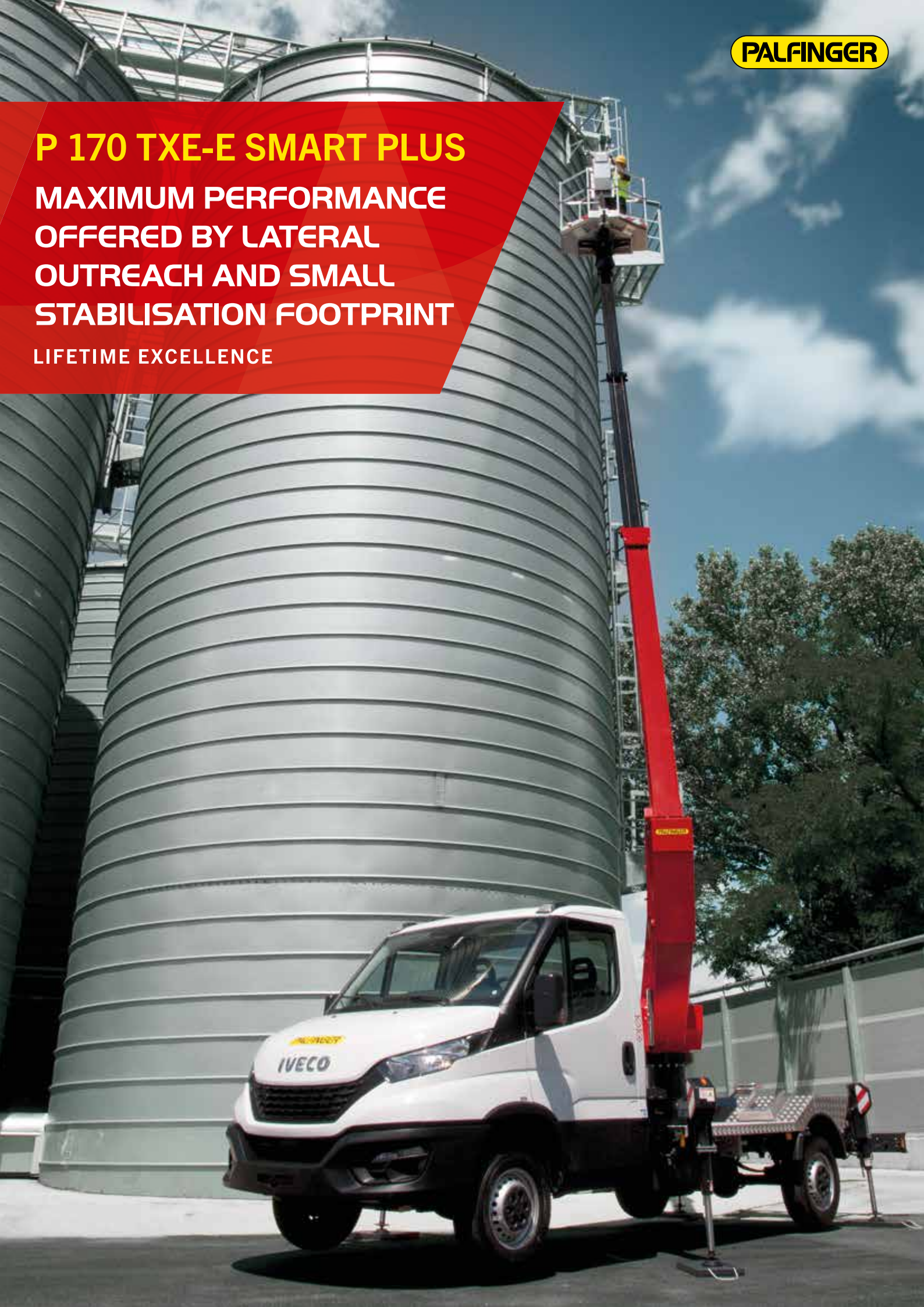

STRENGTHS

- Advanced performance telescopic platform, mounted on a 3.5 tonne truck.
- Multifunction electric controls for greater precision, speed, and manoeuvring comfort
- Vertical stabilisation with frontwards extending outriggers which compensate for uneven and sloping ground
- Platform with three stabilisation possibilities for each working condition:
 - Within the outer vehicle limits: for maximum compactness overall within small spaces
 - With front crossmembers extended: for maximum performance when working in elevated positions
 - Partial stabilisation: for maximum performance with minimum overall dimensions.

STANDARD

- 12V socket on basket
- 230V / 16A socket A or 110V / 16A 12V socket on basket
- Aerial section centring display for aerial part closing
- Air/water line from the column to the basket
- Anti-collision system cab/boom
- Painting with cataphoresis process, with KTL system patented by PALFINGER
- 4 spreader plates with proper housing on the chassis
- Top boom protection
- Electric hour meter
- Cage rotation 90°+ 90°
- Inclinator with audio alarm signal and signal lights relating to aerial work conditions
- Preparation for insulation upgrade ability.

MAIN ACCESSORIES

- 12 V emergency electric pump
- 230V / 16A or 110V / 16A electric pump with quick couplings
- Brushes kit on telescopic boom
- Cable control for emergency use
- Fibreglass basket (replacement for aluminium cage)
- 1000V insulation with fibreglass basket
- Fixed rotary lamp (single or double) on the turret
- Folding left and right bordering side, h 200 mm
- Home function
- Plastic storage toolbox at the rear
- Side protection.







DIMENSIONS







2917



TECHNICAL DATA

	Max. working height	16.9 m
	Max. working height from platform deck	14.9 m
	Max. working outreach	11.8 m
	Min. outrigger width	2.0 m
	Max. outrigger width	3.1 m
	Operating angle of main arm	-21°/+80°
	Turret rotation	370°

	Basket rotation	2x90°
	Basket dimensions	m 1.4 x 0.84 x 1.1 h
	Max. load allowed per basket	250 kg - 230 kg (FBG)
	Stabilization	Vertical, with front arms extendable hydraulically
	Gross vehicle weight	3.5 tonnes

WORK AREA

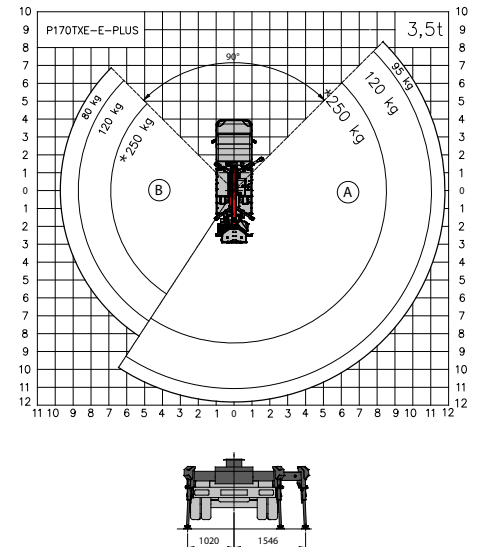
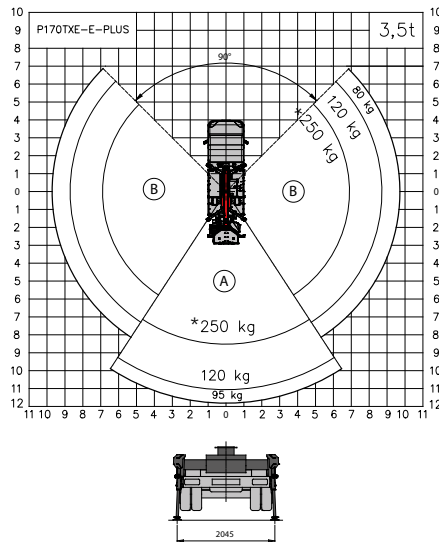
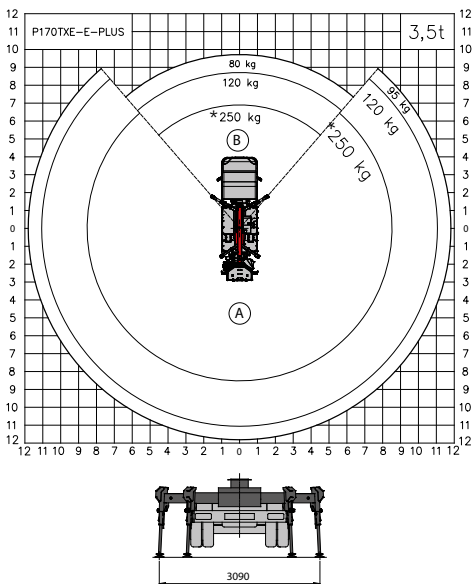
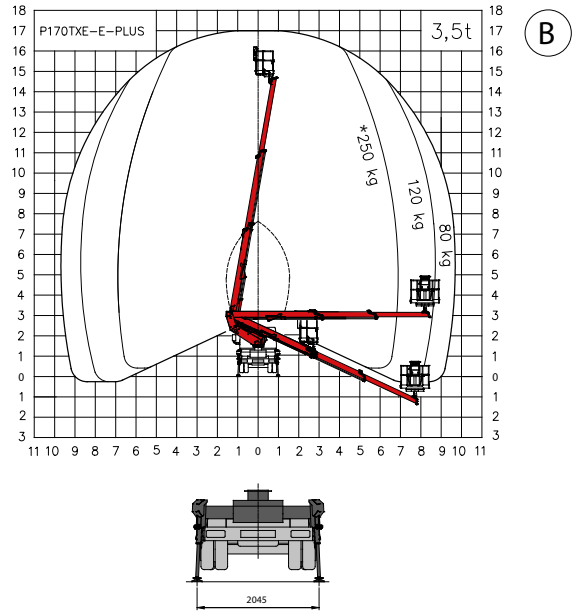
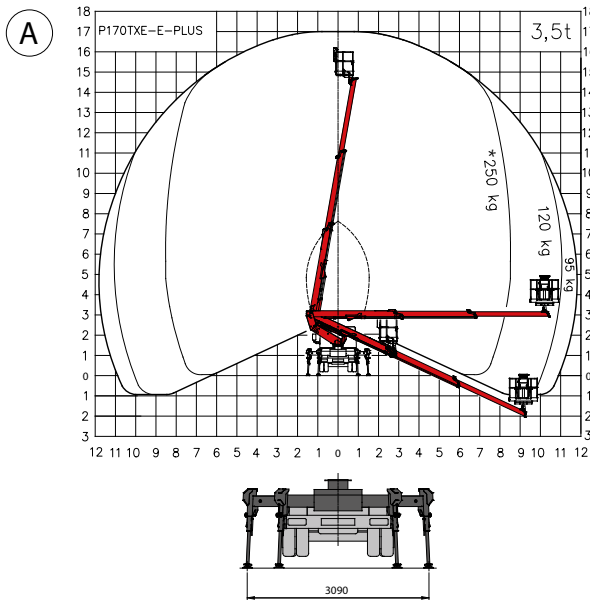

Weights may vary by +/- 5%
 Technical data may vary by +/- 3%
 *230 kg for FBG basket

CONTACT DETAILS**PALFINGER PLATFORMS ITALY SRL**

Via Enrico De Nicola, 31
41122 Modena (MO) - Italy
TEL: +39 059 252426
EMAIL: info@palfingerplatformsitaly.it

KP-P170TXEPM1+EN

The illustrations in the brochure may show units equipped with optional accessories and not always the standard version. National legislation must be complied with during construction/assembly. The dimensions stated are not binding. The company cannot be held responsible for any changes in technical information, inaccuracies, or translation errors.