

SCANIA

P 750

SCANIA P 410

NÚMERO DE REFERENCIA: U- E4013BGY

USADO

DISPONIBLE



INFORMACIÓN DEL PRODUCTO

Información del lugar

PALFINGER IBÉRICA, 28830 - España 

Vendedor

PALFINGER IBÉRICA

Disponibile

Disponibile

Tipo de Producto

Usado

Número de Referencia

U- E4013BGY

Email

dpt-comercial@palfinger.com

j.perez@palfinger.com

Teléfonos de Contacto

0034916088000

0034916088024

PRODUCTO

Fabricante	PALFINGER	Dimensión cesta	3,81 x 1,04 x 1,1 m
Modelo	P 750	Capacidad de carga	600kg
Año	2018	Rotación cesta	2 x 200°
Alcance lateral	39m (100 kg)	Rotación de la Torreta	240°
Altura de Trabajo	75m	Horas de trabajo	1.638

CAMIÓN

Fabricante	SCANIA	Emisiones	EURO VI-C
VIN	YS2P8X20005496971	Axes	8x2
Año	2018	Kilometraje	29.418
Power	410	First registration	E 2270 BGY
		Componentes	Plataforma Aérea

P 750

SENSATIONAL WORKING HEIGHT

LIFETIME EXCELLENCE

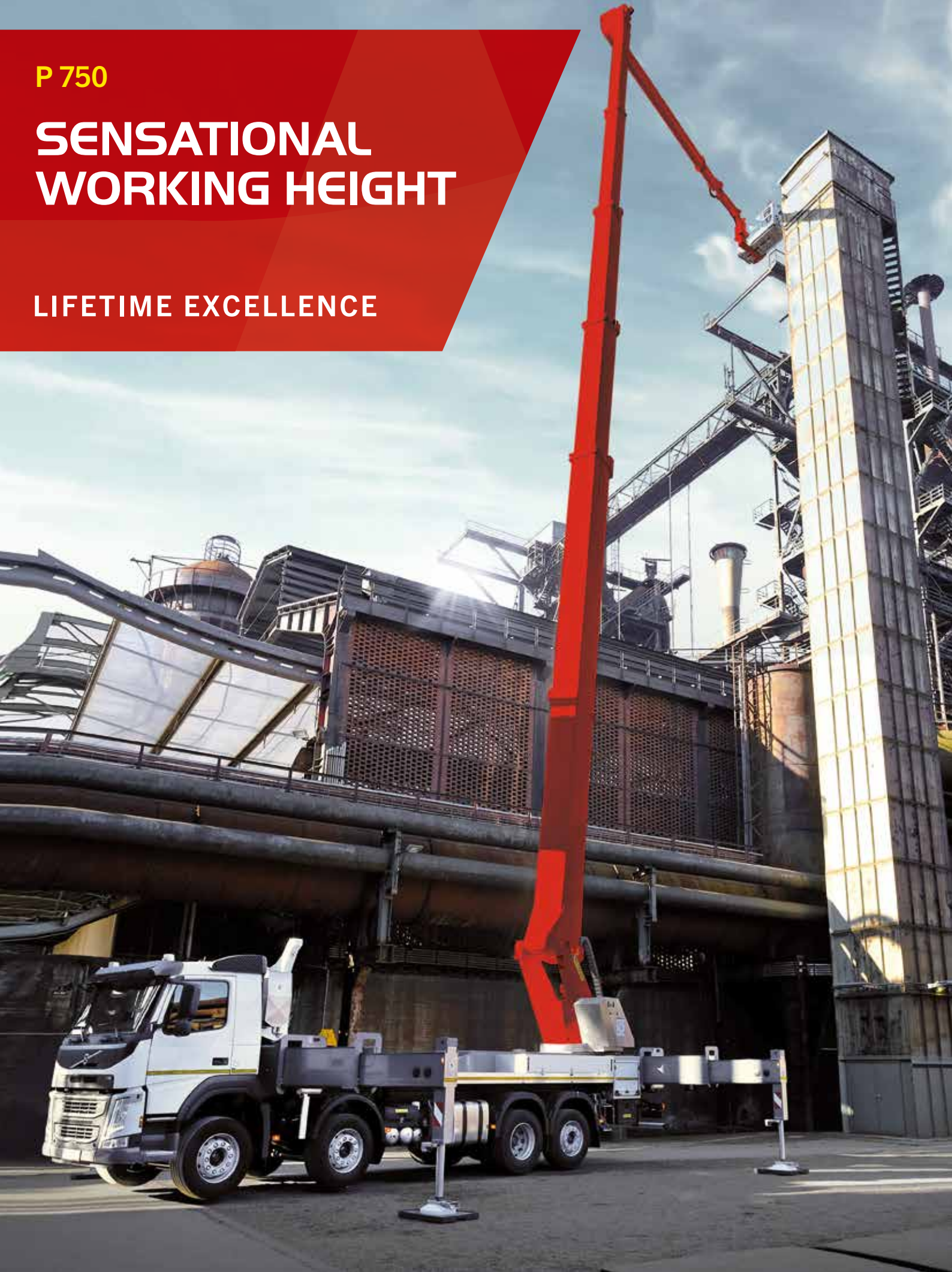

HIGHLIGHTS

- Greater working range thanks to 240° X-jib
- 2 x 200° basket rotation for perfect positioning of the workman basket
- Telescopic upper boom up to 19 m total length
- Automatic telescope lubrication system supplies the lower boom telescopes with grease during platform operation
- Telescopic basket with up to 600 kg basket load and integrated preparation for Powerlift-System
- Hanging basket enables operators to work close to objects

STANDARDS













- Rear view camera
- Memory-Function
- Automated positioning system
- Telescopic basket
- Driver information system
- Safety spreader plates
- 230 V CEE current supply with CEE socket in the workman cage
- Assistance systems

OPTIONS

- Powerlift-System: Transport device for working material with max. 600 kg payload to be carried externally on the basket.
- Material handler/crane in basket for lifting objects from the Powerlift and direct assembly at the place of use (400 kg payload).
- Telescopic camera basket with 600 kg basket load including mount for film illumination
- Ultrasonic sensors to protect the workman basket from collisions
- Mobile radio remote controls for access platform and stabilizer operation
- Access from both sides (access ladder on right and left-hand side) with lighting



TECHNICAL SPECIFICATIONS

	Total weight *	32200 kg		max. outreach	39 m
	Overall length	14.10 m		Rotation angle of turntable	540°
	Width in transportposition	2.54 m		Rotation angle of cage	2 x 200°
	Height in transportposition	3.95 m		Rotation angle of cage boom	240°
	max. stabiliser width	8.89 m		Size of cage	3.88 x 1.05 x 1.10 m
	max. working height	75 m		max. cage load	600 kg
	max. cage bottom height	73 m			

* Depends on truck chassis

WORKING DIAGRAMS

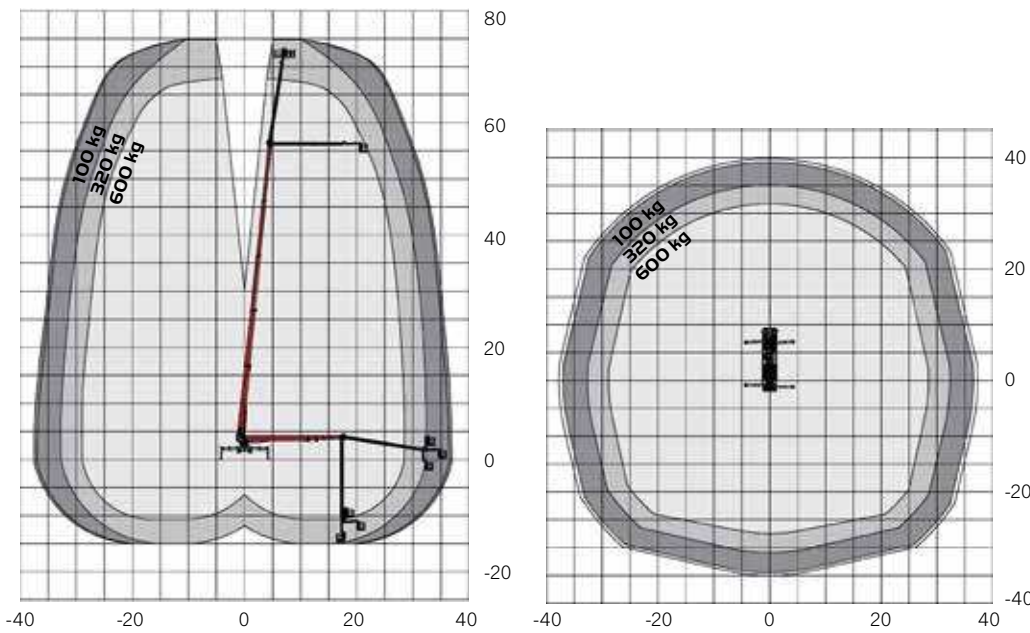

* A possible 2% tolerance is contingent on structural components

DIMENSIONS

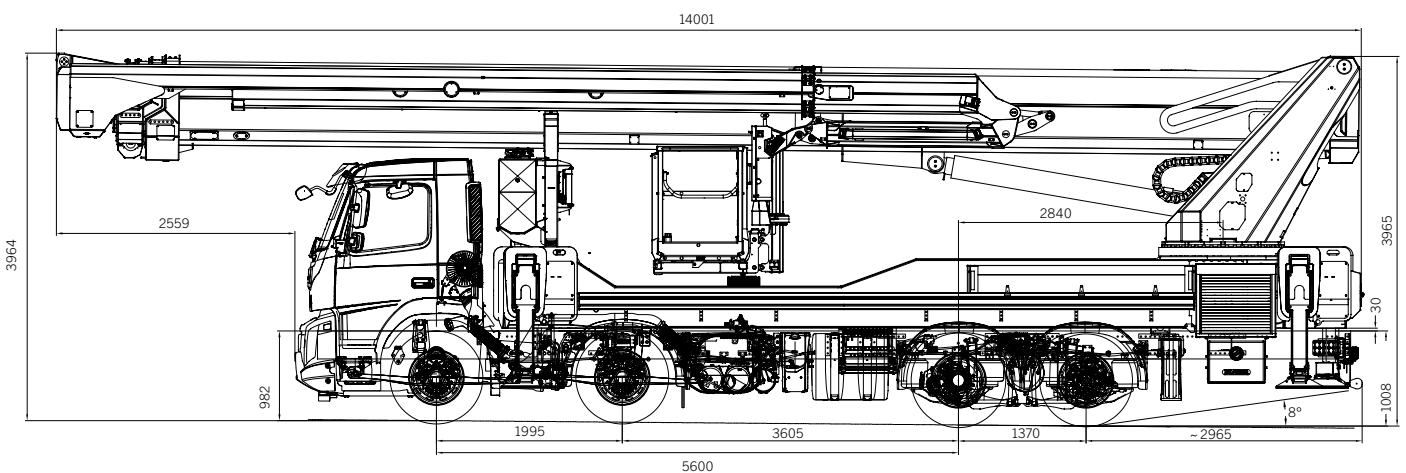

YOUR CONTACT

Palfinger Platforms GmbH

Düsseldorfer Str. 100
47809 Krefeld | Germany

KP-P750M2+EN

Units shown in the leaflet are partially optional equipped and do not always correspond to the standard version. Country-specific regulations must be observed. Dimensions may vary. Subject to technical changes, errors and translation mistakes.