

MAN

P 370 KS

MAN TGM 18.290 4X2 BB

NUEVO

EN PRODUCCIÓN



INFORMACIÓN DEL PRODUCTO

Información del lugar

Modena, 41122 - Italia 

Vendedor

Palfinger SRL

Disponible en

31.05.2026

Tipo de Producto

Nuevo

paldrive.detail.dealercontact

Palfinger SRL

Email

info@palfingerplatformsitaly.it

Teléfonos de Contacto

059252426

PRODUCTO

Fabricante	PALFINGER	Rotación columna	500°
Modelo	P 370 KS	Dimensión cesta	2,00 x 0,80 x 1,10 m
Año	2026	Capacidad de carga	500 kg
Alcance lateral	31,5 m	Rotación de la Torreta	185°
Altura de Trabajo	37,0 m	Material Cesta	Aluminium

CAMIÓN

Fabricante	MAN	Power	213 kW / 290 PS
Tipo de Vehículo	TGM 18.290	Emisiones	Euro 6
Drivers cabine	C	Axes	4x2
DEE (mm)	4.425 mm	Masa Máxima Autorizada	18.000 kg

Working diagrams

Palfinger P 370KS

on

MAN 18.XXX 16t

The working diagrams shown below have the following preconditions:

Solid line:

Standard working diagram

Working height = height of basket bottom + 2.0 m

The basket is in basic position (not turned) and retracted

The following applies generally:

All specifications refer to standard aluminum basket without additional equipment

Maximum inclination 0,5°

Set-up inclination is max. 2° with automatic range adjustment.

Note on working diagram:

Additional attachments that deviate from the standard reduce range and basket load

Special baskets have different ranges

Reach at plastic workman basket ~ 0,8m reduced

Permitted maximum basket load according to technical description

The outreaches are approximate dimensions and depend on the chassis, the type of support and the lifting platform's additional equipment.

Illustrations of truck and unit are only of symbolic nature and do not allow any conclusions regarding technical design.

Subject to technical change!

Palfinger P 370KS

Rear view

Extension of stabiliser
outrigger

Front left	100%
Front right	100%
Rear left	100%
Rear right	100%

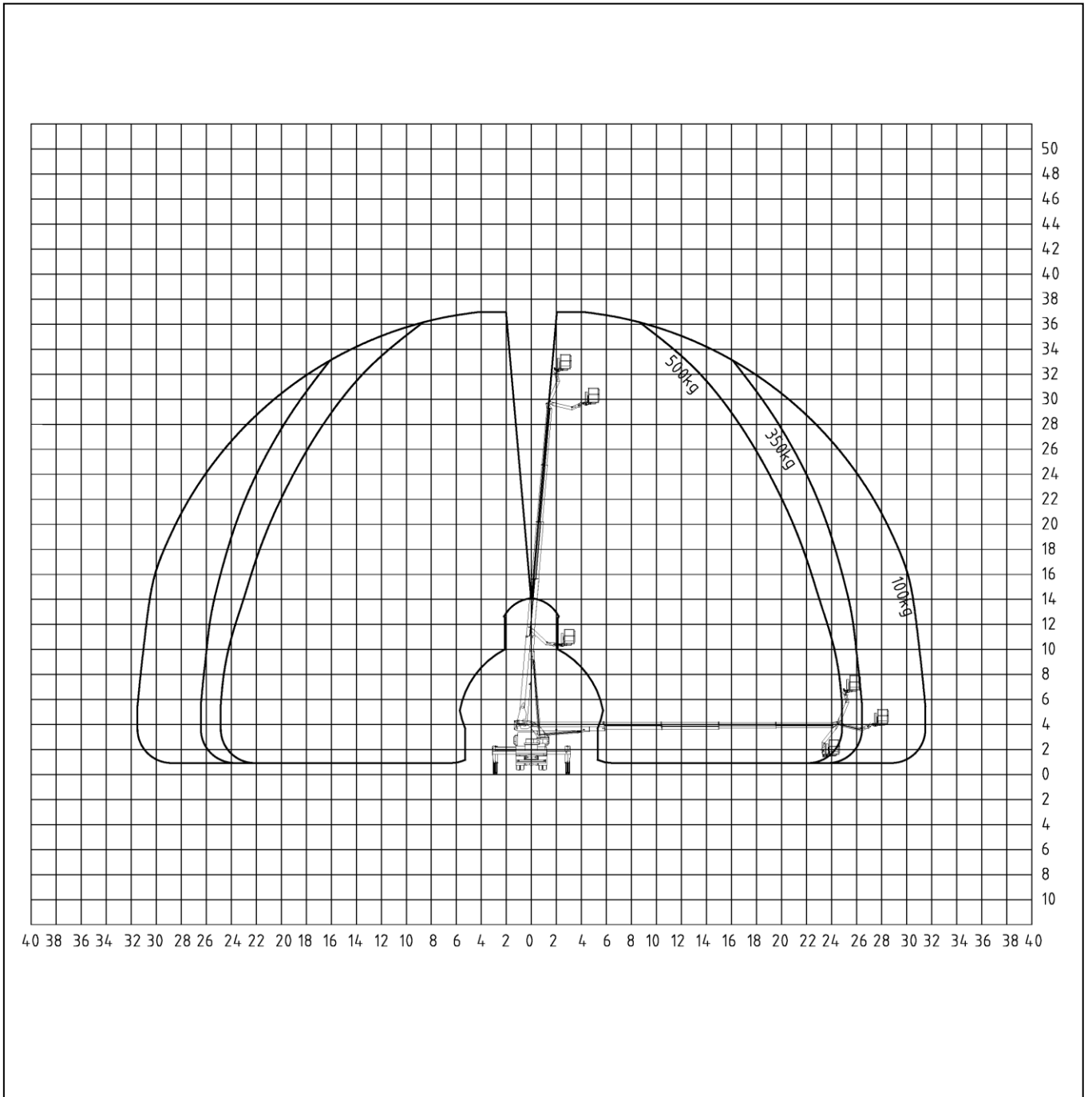

Palfinger P 370KS

Top view

Extension of stabiliser
outrigger

Front left	100%
Front right	100%
Rear left	100%
Rear right	100%

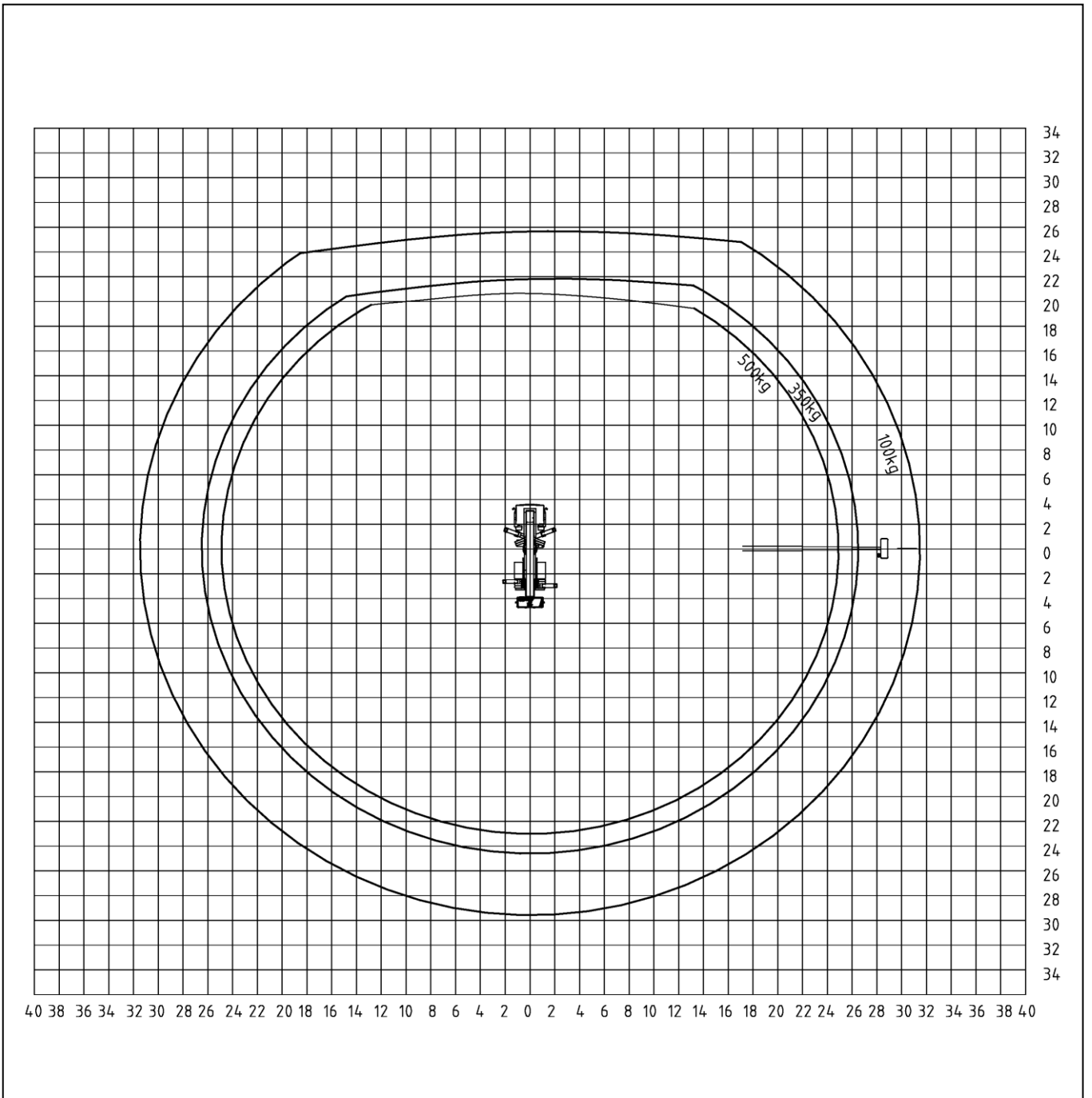

Palfinger P 370KS

Left view

Extension of stabiliser
outrigger

Front left	100%
Front right	100%
Rear left	100%
Rear right	100%

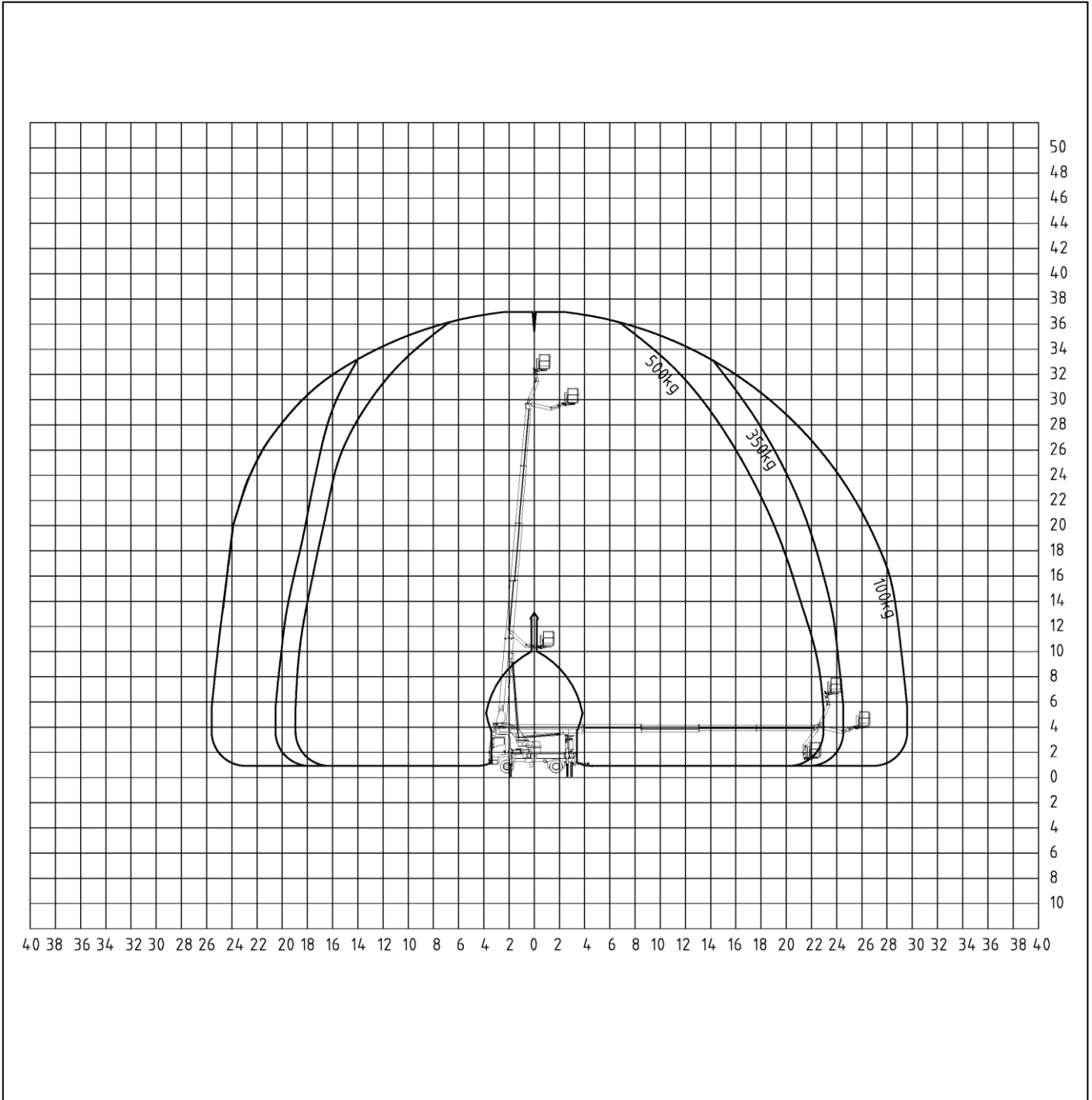

Palfinger P 370KS

Rear view

Extension of stabiliser
outrigger

Front left	50%
Front right	50%
Rear left	50%
Rear right	50%

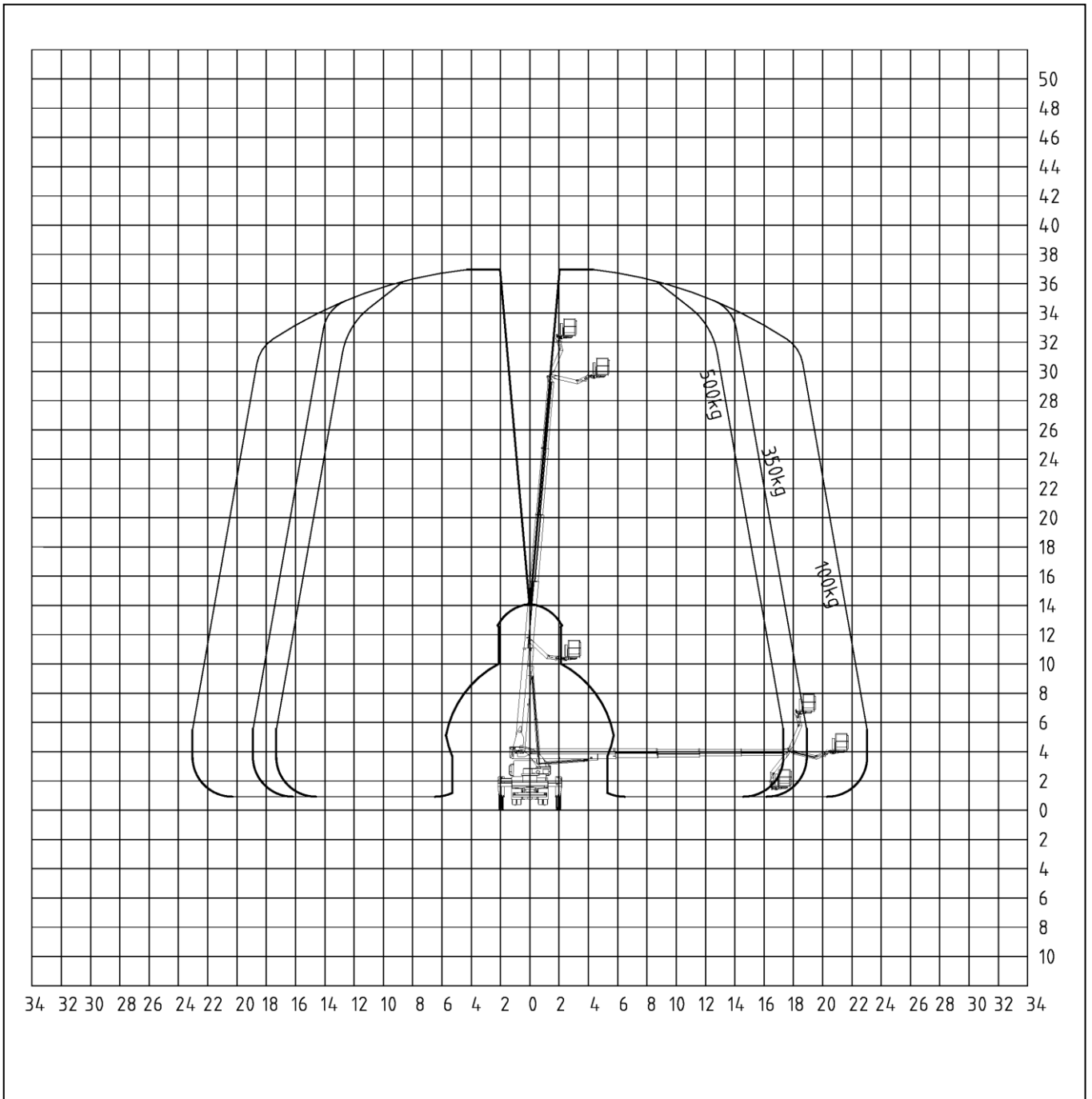

Palfinger P 370KS

Top view

Extension of stabiliser
outrigger

Front left	50%
Front right	50%
Rear left	50%
Rear right	50%

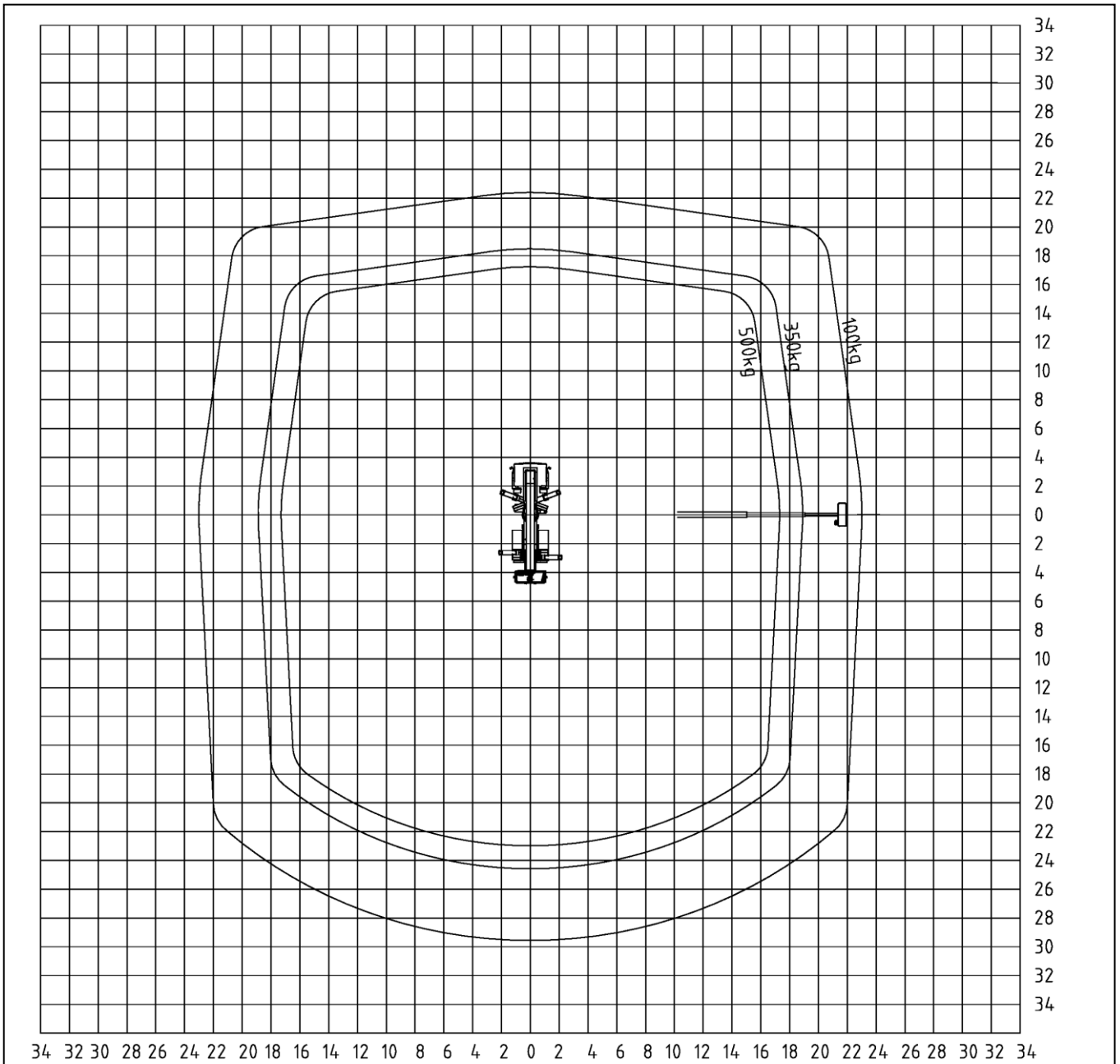

Palfinger P 370KS

Left view

Extension of stabiliser
outrigger

Front left	50%
Front right	50%
Rear left	50%
Rear right	50%

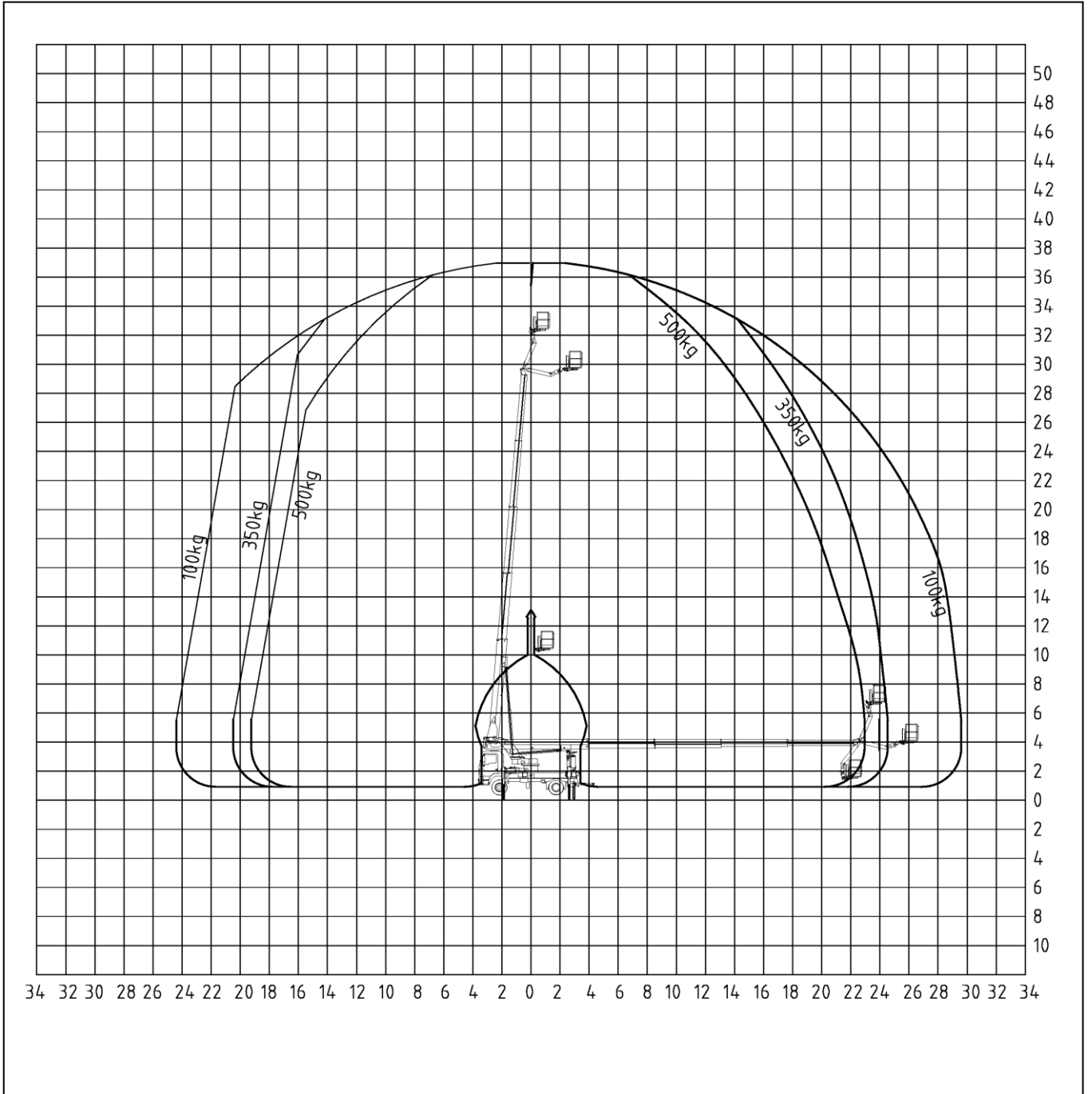

Palfinger P 370KS

Rear view

Extension of stabiliser
outrigger

Front left	0%
Front right	0%
Rear left	0%
Rear right	0%

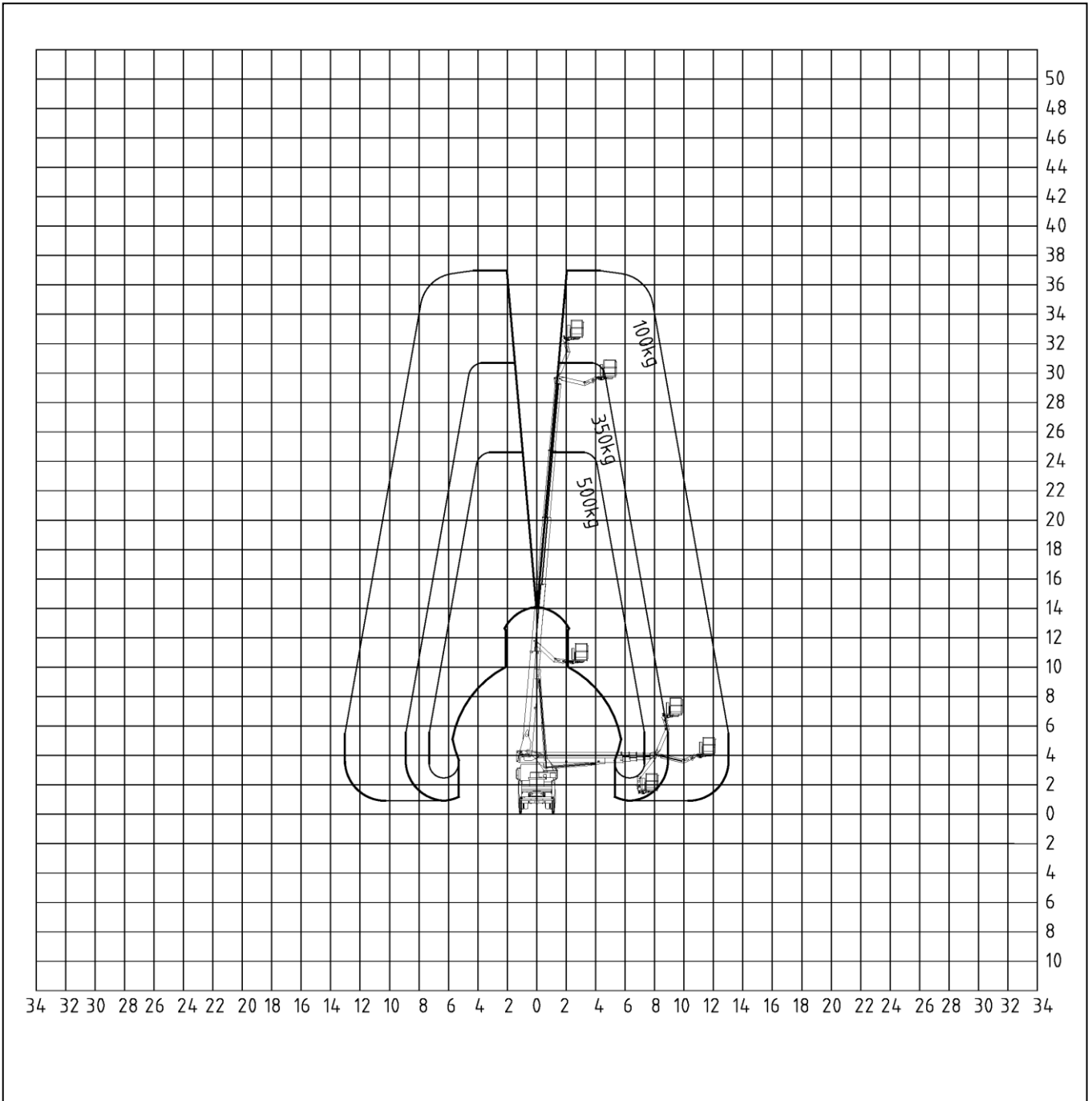

Palfinger P 370KS

Top view

Extension of stabiliser
outrigger

Front left	0%
Front right	0%
Rear left	0%
Rear right	0%

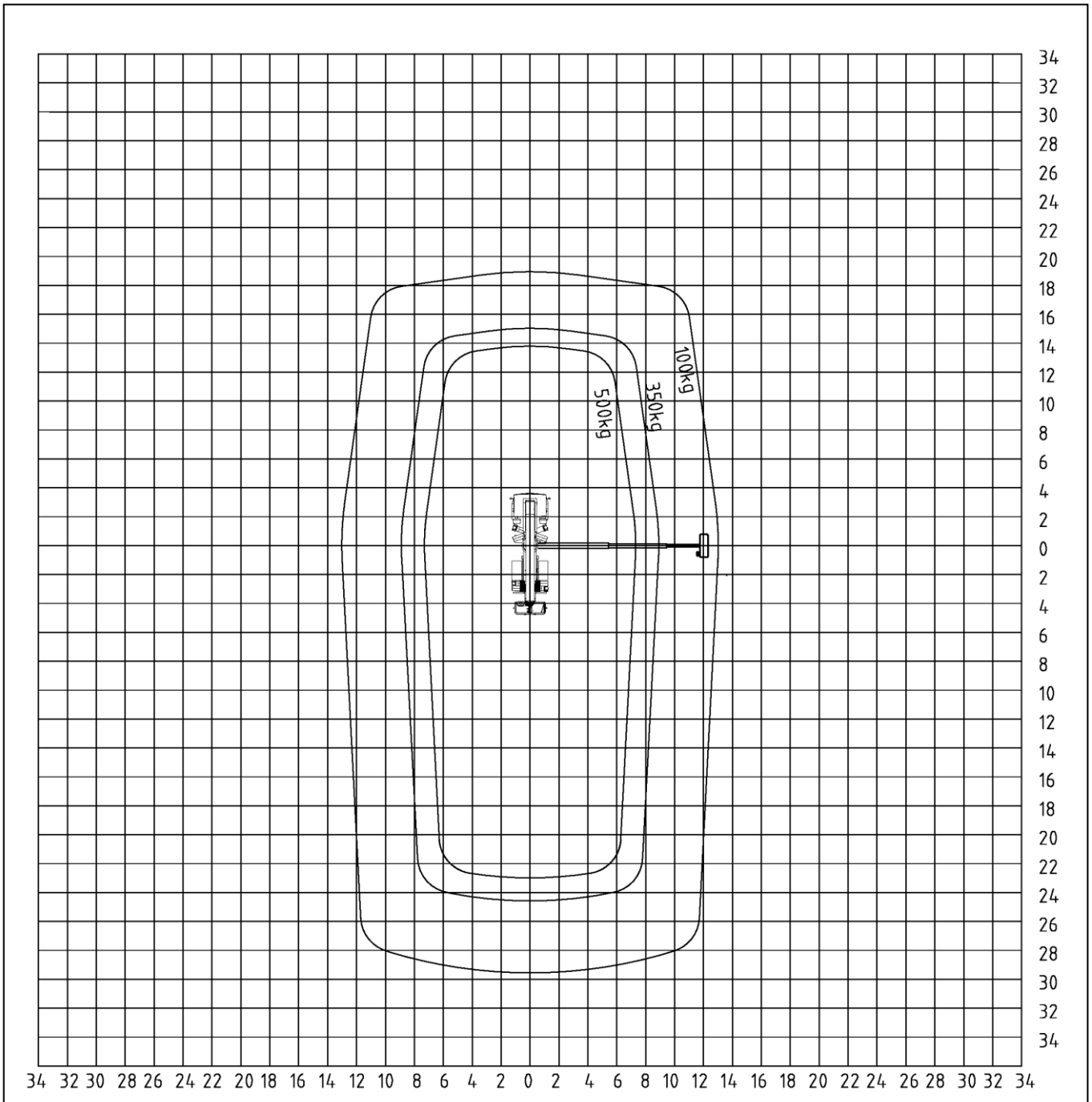

Palfinger P 370KS

Left view

Extension of stabiliser
outrigger

Front left	0%
Front right	0%
Rear left	0%
Rear right	0%

