

## C1500L

CONTRACT NUMBER: 200010121

NEW

ON REQUEST



### SPECIFICATION

C1500L Tail Lift

### OFFER INFORMATION

Location details

Köstendorf, 5203 - Austria

Dealer Name

PALFINGER EMEA GmbH



Availability

On request

Product type

new

Contract number

200010121

Dealer E-mail

[sales@palfinger.com](mailto:sales@palfinger.com)

Dealer phone

[004366488345792](tel:004366488345792)

**MBB C 1500 L**

# THE EFFICIENT AND FUNCTIONALLY TAIL LIFT

**LIFETIME EXCELLENCE**



# MBB C 1500 L

## THE EFFICIENT AND FUNCTIONALLY TAIL LIFT

### MBB C 1500 L

- 1500 kg lifting capacity at 600 mm load centre
- Robust 4-cylinder configuration
- Available with aluminium or steel platform
- Lightweight

### DIAGRAM

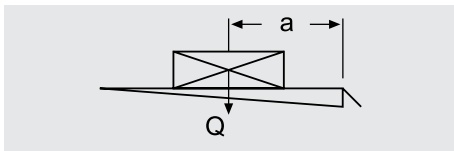

MBB C 1500 L	
a (mm)	Q (kg)
600	1500
720	1250
900	1000
1200	750

### WEIGHT

Platform type	depth (mm)	width (mm)	weight (kg)
Alum.	1550	2500	390
	1700	2500	398
	1825	2500	404
	1950	2500	410
	2050	2500	415
	2200	2500	423
Steel	1509	2500	528
	1809	2500	568
	2109	2500	608

### TECHNICAL DATA

Lifting capacity	1500 kg
Main beam	180 x 180 mm
Lifting gear hydraulics	2 x lift cylinder
	2 x tilt cylinder
Platform overlap with floor	- 57 mm
Lift arm pitch	1310 mm
Load centre - longitudinal	600 mm
Load centre - lateral	50 % of the full load on one side
Inclination angle of the platform	+90° to - 10°

### DIMENSIONS

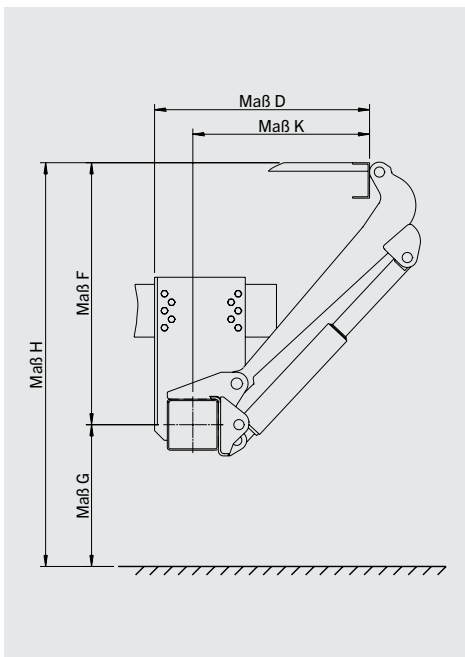

Lifting arms (in mm)	700	800	900
H (max.) loading height unloaded	1256	1409	1546
H (min.) loading height loaded	906	922	998
F (max.) middle of main beam to upper edge of loading floor	728	811	894
K (min.) at dimension F (max.)	515	571	627
D (min.) installation space (min.)	665	721	777
F (min.)	529	572	625
K (max.) at dimension F (min.)	710	801	886
D (max.) installation space (max.)	860	951	1036

**PALFINGER Tail Lifts GmbH**  
 Fockestraße 53  
 27777 Ganderkesee  
 Deutschland  
[www.palfinger.com](http://www.palfinger.com)



**PALFINGER TAIL LIFTS**

**ASSEMBLY INSTRUCTIONS**

**TAIL LIFTS  
STANDARD**





# **Assembly instructions**

for  
PALFINGER Tail Lifts  
Tail Lift Standard

07-500.99-04.10-03

Ref. no.: 2032342

15.06.2017

A 22839



## Table of contents

<b>1</b>	<b>About these instructions .....</b>	<b>7</b>
1.1	Abbreviations used .....	7
1.2	Enclosed documents .....	7
<b>2</b>	<b>Important safety information .....</b>	<b>9</b>
2.1	Personnel qualifications .....	9
2.2	Warning notices in these assembly instructions .....	10
2.3	You must take these points into account during installation ...	11
<b>3</b>	<b>Required tools and auxiliary equipment .....</b>	<b>13</b>
<b>4</b>	<b>List of models and scope of delivery .....</b>	<b>14</b>
4.1	Standard tail lift .....	15
4.2	Tail lift with welded consoles and slide-in unit .....	16
4.3	Tail lift with bolted consoles and slide-in unit .....	16
4.4	Tail lift with platform and turning unit .....	17
4.5	Scope of delivery .....	17
<b>5</b>	<b>Preparing for installation .....</b>	<b>18</b>
<b>6</b>	<b>Preparing vehicle .....</b>	<b>20</b>
6.1	Removing projecting parts of the vehicle .....	21
6.2	Creating cutouts for the lifting mechanism (optional) .....	22
6.3	Reinforcing rear cross-member (optional) .....	22
6.4	Preparing vehicles with box bodies .....	23
<b>7</b>	<b>Installing lifting mechanism .....</b>	<b>24</b>
7.1	Installation with installation aids .....	24
7.2	Installation with attached platform .....	33
<b>8</b>	<b>Establishing electrical connections .....</b>	<b>37</b>
8.1	Establishing connection to vehicle battery .....	37
8.2	Installing and connecting the control unit .....	39
8.3	Mounting the control panel holder .....	40
8.4	Connecting the manual cable switch/remote control (optional) .....	40
<b>9</b>	<b>Installing and connecting the platform .....</b>	<b>42</b>
9.1	Moving up and positioning platform .....	42
9.2	Bolting the platform to the control rod .....	43
9.3	Bolting the platform to the first tilt cylinder .....	44
9.4	Adjusting the tilt cylinder .....	47
9.5	Bolting the platform to the second tilt cylinder (apart from the types DUO and 1000 E) .....	48
9.6	Connecting plug for foot-operated switch and Warnfix .....	48
9.7	Installing tilt sensors .....	49
<b>10</b>	<b>Adjusting and testing installed tail lift .....</b>	<b>50</b>
10.1	Opening/closing platform and setting tilt switch b13 .....	50

10.2	Air bleeding the hydraulic cylinders .....	51
10.3	Checking horizontal position on ground .....	51
10.4	Performing an oil level check .....	52
10.5	Checking screw connections .....	52
10.6	Attaching warning strips, safety point decals (optional) and type plate .....	53
10.7	Adjusting the pressure switch of the hydraulic support (C 750 L to C 1000 L) .....	54
10.8	Performing acceptance test as per test book .....	55
<b>11</b>	<b>Index .....</b>	<b>56</b>
<b>12</b>	<b>Hydraulic circuit diagrams .....</b>	<b>58</b>

# 1 About these instructions

These assembly instructions contain important information to ensure that the **PALFINGER Tail Lifts** tail lift is safely and properly installed.

- ▶ Read these assembly instructions all the way through, particularly the chapter "Important safety information" on page 9, before attaching the tail lift.
- ▶ Observe all the generally applicable statutory and other binding European and national regulations on accident prevention, handling hazardous substances and on environmental protection.

## 1.1 Abbreviations used

A list of the abbreviations and symbols used in these assembly instructions is provided below.

Abbreviation/ symbol	Meaning
ETMA	European Taillift Manufacturer Association
GGVS	Hazardous goods ordinance road

## 1.2 Enclosed documents

In addition to this assembly manual, you will receive additional documents with your **PALFINGER Tail Lifts** tail lift. They form part of these assembly instructions and should be observed.

- ▶ Observed all documents enclosed with your ordered **PALFINGER Tail Lifts** tail lift.
- ▶ In addition, you should also observe the operating instructions for the **PALFINGER Tail Lifts** tail lift and all documents from the vehicle manufacturer.

The following documents are enclosed with the assembly instructions for the **PALFINGER Tail Lifts** tail lift:

- Operating instructions
- Test book
- Assembly instructions (short form)
- Underrun protection unit certificate
- Small and large test plate
- ETMA adhesive decal

- Brief operating instructions
- Type plate
- Attachment report (attachment diagram)
- General installation drawing

## 2 Important safety information

The **PALFINGER Tail Lifts** tail lift has been built according to the state-of-the-art and to recognised safety engineering rules. Nevertheless there is a danger of personal injury and material damage if you do not comply with the instructions in this chapter and in this operating manual.

- ▶ Read this operating manual thoroughly all the way through, before mounting the **PALFINGER Tail Lifts** tail lift.
- ▶ Keep the assembly manual at hand in a good condition so that it is always legible. Make sure that it is available to all responsible fitters at all times.
- ▶ Always ensure that this assembly manual and the supplied documents are always passed on along with the **PALFINGER Tail Lifts** to third parties.

### 2.1 Personnel qualifications

The assembly and commissioning of the **PALFINGER Tail Lifts** tail lift require systematic knowledge of mechanical, electrical, hydraulic and pneumatic systems as well as familiarity with the associated specialist terms. Consequently to ensure operational safety these activities may only be executed by trained and authorised specialists, who have been instructed in safety engineering aspects, or by an instructed person working under the supervision of a specialist.

A specialist is a person who, due to his specialised training, knowledge, and experience, as well as knowledge of the applicable regulations and guidelines, can evaluate the tasks assigned to him, recognise possible dangers, and implement suitable safety measures. A specialist must comply with the applicable technical rules.

## 2.2 Warning notices in these assembly instructions

In these assembly instructions, safety messages precede a procedure which incurs risks of personal injury or material damage.

Safety messages are structured as follows:

 <b>SIGNAL WORD</b>
<b>Description of type and source of the hazard</b>
Description of consequences of non-observance
▶ Description of measures for avoiding danger

The **warning triangle** indicates a risk of fatal or severe injuries.



The **signal word** indicates the severity of the danger.

The paragraph "**Type and source of hazard**" describes the nature and source of the danger.

The paragraph "**Consequences**" describes possible consequences of ignoring the warning.

The "**Avoidance of hazard**" paragraphs indicate how to avoid the danger. It is essential that the measures to avert danger are complied with.

The signal words have the following meanings:

Signal word	Application
 <b>DANGER!</b>	Indicates a danger that will certainly result in death or severe injury if you fail to avoid it.
 <b>WARNING!</b>	Indicates a danger that may result in death or severe injury if you fail to avoid it.
 <b>CAUTION!</b>	Indicates a danger that may result in minor to medium severe injuries if you fail to avoid it.
<b>NOTICE!</b>	Indicates possible material damage. The environment, equipment or the <b>PALFINGER Tail Lifts</b> tail lift may be damaged if you fail to avoid this danger.
<b>NOTE</b>	If you do not observe this information, the installation process may be adversely affected.

## 2.3 You must take these points into account during installation

### 2.3.1 General instructions

- Observe this installation manual and in particular all the safety instructions.
- Structural modifications may only be performed by **PALFINGER Tail Lifts** contract workshops. Your nearest contract workshop and other contact information can be found in the workshop directory.
- Only use **PALFINGER Tail Lifts** original parts during installation work.
- Observe all applicable accident prevention regulations.
- Observe the vehicle manufacturer's attachment guidelines.
- Observe the respectively applicable general installation diagram from **PALFINGER Tail Lifts**.
- Observe the respectively applicable general attachment report (attachment diagram) from **PALFINGER Tail Lifts**.
- Make sure that any welding work is only performed by certified welders. It is essential to comply with the vehicle maker's specifications as well as the applicable standards and regulations for welding work.

### 2.3.2 Before starting installation

- Before starting installation, read the safety instructions in the operating manual, especially the chapter "Care and maintenance".
- Observe the vehicle manufacturer's attachment guidelines.
- Observe the additional assembly instructions that were included with the respective components (e.g. camera system).
- Place the vehicle on a level and firm surface for installation and align the vehicle so it is also level.
- If the vehicle has air suspension, deactivate this.
- Remove the battery terminals and ABS plugs before installation.

### 2.3.3 During installation

- When connecting the hydraulic parts, ensure that the connections are clean and that no contamination can get into the hydraulic circuit.
- Make sure that the **PALFINGER Tail Lifts** tail lift and its moving parts, the coupling, the brake system, the oil lines, the pneumatic lines and the cabling of the vehicle are not damaged.
- Do not apply any overpressure to the functions lift/lower, open/close, retract or extend before the installation is entirely completed.

### 2.3.4 During initial commissioning

- During initial commissioning of the **PALFINGER Tail Lifts** tail lift, check whether all safety and warning features are available and functional.
  - Warning strips
  - Warning lights
  - Roll bar
- Lubricate all bearings and pins before initial commissioning.

### 3 Required tools and auxiliary equipment

To assemble your **PALFINGER Tail Lifts** tail lift you will need the following tools and auxiliary equipment:

<b>Tools</b>
Wrench size in mm: 6, 8, 10, 13, 32, 36, 41, 46, 50, 60, 65, 70
Set of Allen keys up to 24 mm
Torque wrench 25 up to 300 Nm
Socket wrench 4, 6
4x screw clamps
Peening tool
Hand-held electric drill
2-hand electric drill
Spiral drill up to 14 mm diameter
Crimping tool for cable lugs (16 mm <sup>2</sup> , 25 mm <sup>2</sup> , 35 mm <sup>2</sup> )
Insulation stripper
Side cutter
TORX screwdrivers
Mallet
Impact wrenches size in mm: 46, 50, 60, 65
Locking pliers for external rings A2
<b>Auxiliary equipment</b>
Assembly aid (assembly device)
Stop bracket
Marker
Tape measure
Trolley jacks
Hot air dryer
1 set of punches
Battery terminal grease
Lubricant grease for bearing pins
Grease gun

## 4 List of models and scope of delivery

Below a list of standard version models of **PALFINGER Tail Lifts** tail lifts.

The following models are available:

MBB C 1000 S – C 3000 S

MBB C 1000 LD – C 2500 L

MBB C 1500 SZ – C 2500 LZ

MBB C 1500 SK – C 2500 SK

MBB C 750 SPLD SPRD –  
C 1000 SPL SPR

MBB C 750 LD – C 1000 L

MBB C 1000 ML – C 1500 ML

MBB C 1000 ML PRO –  
C 1500 ML PRO

MBB C 750 S

MBB C 750 LX

MBB C 750 SX

MBB C 500 LD – C 750 L

MBB C 750 SPL SPR

MBB C 1500 LX – C 2000 LX

MBB C 500 LG

MBB C 1000 SB – C 1500 LB

The following general drawings show the structure of the **PALFINGER Tail Lifts** tail lift and of the individual sub-assemblies.

## 4.1 Standard tail lift

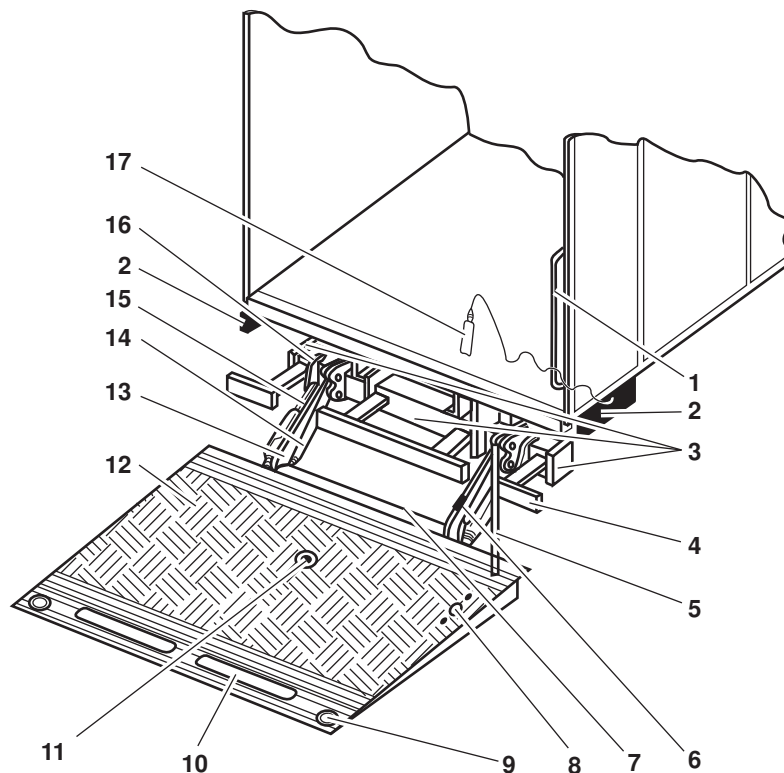

- |   |   |
|---|---|
| <b>1</b> Attachment grab handle (not included in scope of delivery) | <b>9</b> Warning lamps (option)           |
| <b>2</b> Side control panel (option)                                | <b>10</b> Startup rail (roll bar, option) |
| <b>3</b> Hydraulic unit and controller                              | <b>11</b> Useful load centre of gravity   |
| <b>4</b> Underride protection                                       | <b>12</b> Platform                        |
| <b>5</b> Platform support rod (not included in scope of delivery)   | <b>13</b> Torsion frame                   |
| <b>6</b> Tilt switch b13, tilt switch b15                           | <b>14</b> Lift cylinder                   |
| <b>7</b> Tilt switch b16, tilt switch b15                           | <b>15</b> Tilt cylinder                   |
| <b>8</b> Foot-operated switch (option)                              | <b>16</b> Stand tube                      |
|   | <b>17</b> Manual cable switch (option)    |

## 4.2 Tail lift with welded consoles and slide-in unit

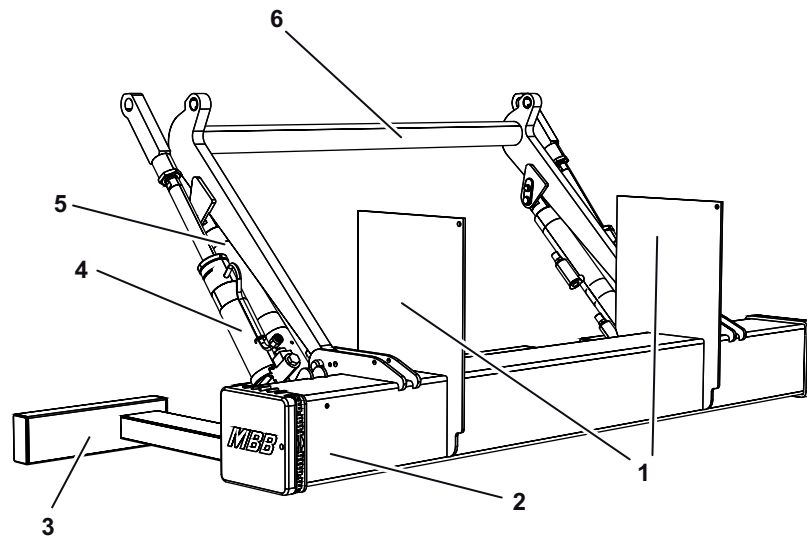

- |   |                       |   |               |
|---|-----------------------|---|---------------|
| 1 | Welded console plates | 4 | Tilt cylinder |
| 2 | Hydraulic unit        | 5 | Lift cylinder |
| 3 | Underide protection   | 6 | Lift rocker   |

## 4.3 Tail lift with bolted consoles and slide-in unit

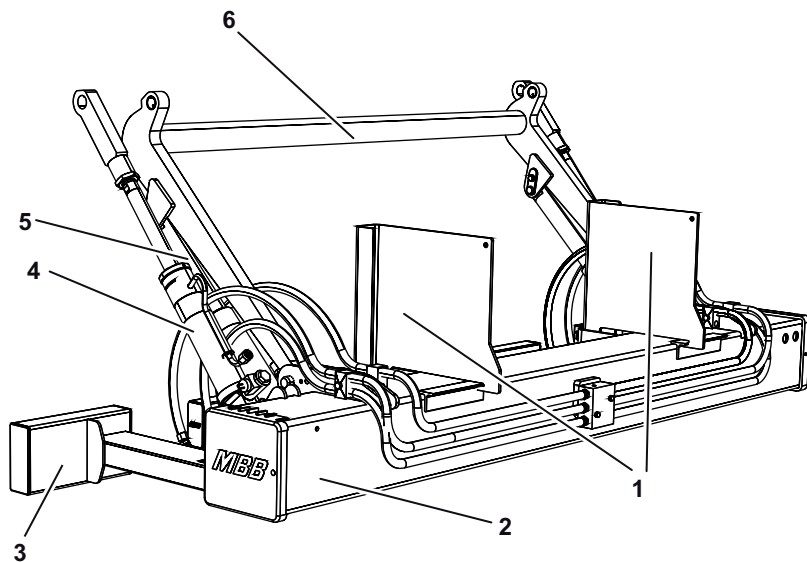

- |   |                       |   |               |
|---|-----------------------|---|---------------|
| 1 | Bolted console plates | 4 | Tilt cylinder |
| 2 | Hydraulic unit        | 5 | Lift cylinder |
| 3 | Underide protection   | 6 | Lift rocker   |

## 4.4 Tail lift with platform and turning unit

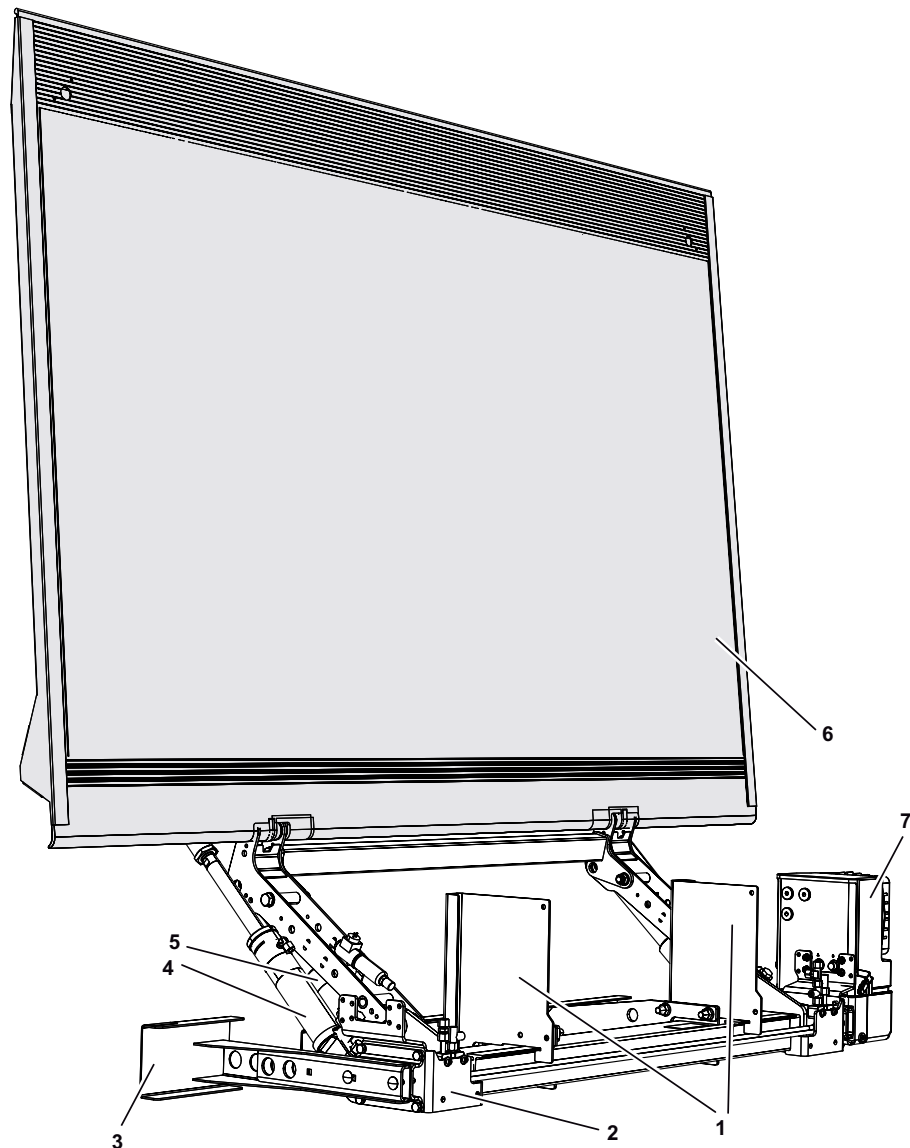

- |                         |                 |
|-------------------------|-----------------|
| 1 Bolted console plates | 4 Tilt cylinder |
| 2 Hydraulic unit        | 5 Lift cylinder |
| 3 Underride protection  | 6 Platform      |
|                         | 7 Turning unit  |

## 4.5 Scope of delivery

The scope of delivery of your **PALFINGER Tail Lifts** tail lift is based on the model you ordered and any agreed special accessories.

## 5 Preparing for installation

This chapter contains basic information about what you need to remember when preparing to install your **PALFINGER Tail Lifts** tail lift. This information relates to the "standard" versions of all **PALFINGER Tail Lifts** tail lift models.

- ▶ First read this assembly manual through and then follow the instructions step-by-step.
- ▶ You should also observe the operating manual for your **PALFINGER Tail Lifts** tail lift and in particular all the safety instructions.
- ▶ Perform all the preparatory work properly and carefully.
- ▶ If in doubt or if you have any questions, please contact your **PALFINGER Tail Lifts** dealer before proceeding with work.

### **⚠ CAUTION**

#### **Incorrect installation can result in damage to the vehicle and the tail lift!**

The vehicle and the tail lift may be damaged if you incorrectly install the tail lift.

- ▶ It is essential to comply with the vehicle maker's guidelines for mounting attachments
- ▶ It is especially important to comply with the tail lift's maximum permitted rated load and the axle spacing for the tail lift.

- ▶ Before starting installation, please check the following points:

- Is the delivered **PALFINGER Tail Lifts** tail lift consistent with your order and have all parts required for installation been correctly delivered?
- Have the general installation diagram and the attachment report (attachment diagram) been provided in accordance with your ordered **PALFINGER Tail Lifts** tail lift type?
- Is the vehicle suitable for mounting the **PALFINGER Tail Lifts** tail lift? Do the vehicle dimensions correspond to those of the **PALFINGER Tail Lifts** tail lift?
- Is the operating voltage of the vehicle battery appropriate for the rated voltage of the **PALFINGER Tail Lifts** tail lift?
- Is the capacity of the vehicle battery sufficient for the **PALFINGER Tail Lifts** tail lift? The following capacities are required:

Load bearing capacity	12 V	24 V
500 - 1000 kg	143 Ah	105 Ah
1500 - 3000 kg	180 Ah	180 Ah

- Are all required tools and auxiliary equipment available? Are any other special tools required?
- Do cutouts have to be made for the lifting mechanism?
- Should a seal be installed in vehicles with a box body without rear doors? If yes, you must allow a space between the platform and the box body.
- Is the use of trailers planned? If yes, sufficient space for the trailer coupling must be available and the free movement of the drawbar must be ensured.
- Has allowance been made for the space required for the optional grab handle (25 mm finger room between platform and handle)?

When all these points have been checked off, you can start with the installation of your **PALFINGER Tail Lifts** tail lift. The installation consists of several steps, which are described in more detail on the following pages. They include:

- preparation of vehicle or vehicle chassis (see chapter 6 on page 20),
- installing the lifting mechanism (see chapter 7 on page 24),
- establishing electrical connections (see chapter 8 on page 37),
- installing and connecting the platform (see chapter 9 on page 42),
- adjusting and testing the platform (see chapter 10 on page 50).

## 6 Preparing vehicle

Before mounting the **PALFINGER Tail Lifts** tail lift on your vehicle, you must prepare the vehicle accordingly. The specific steps vary according to the intended purpose and the vehicle type.

### Technical parameters

You can obtain the most important technical parameters from the general installation diagram and thus determine in advance the scope of work required to prepare the vehicle. These include:

- the installation height
- the required projection
- the position of the platform and lifting mechanism under the vehicle
- the fixing of installation aids
- the required space for the lifting mechanism for any offset rear lights
- the thickness of the vehicle's rear cross-member and any cutouts required in the lower tail chassis

To prepare the vehicle for installation of the **PALFINGER Tail Lifts** tail lift, the following steps must be completed:

- remove projecting parts of the vehicle (see chapter 6.1 on page 21),
- make any necessary cutouts for the lifting mechanism and reinforce these (see chapter 6.2 on page 22),
- reinforce the rear cross-member, if required (see chapter 6.3 on page 22).

### Vehicles with box bodies

Additional steps may be necessary for vehicles with box bodies or flat beds (with or without gates) (see chapter 6.4 on page 23). These include:

- mounting the supplied connecting profile on the vehicle,
- preparing and mounting bridging profiles/spacers,
- mounting the optional sealing system.

## 6.1 Removing projecting parts of the vehicle

### ATTENTION

#### Damage and loss of components

If you do not safely store the removed components in a dry place, they may be damaged or lost.

- ▶ Remove the interfering components carefully from the vehicle.
- ▶ Store the removed components in a secure, dry place.

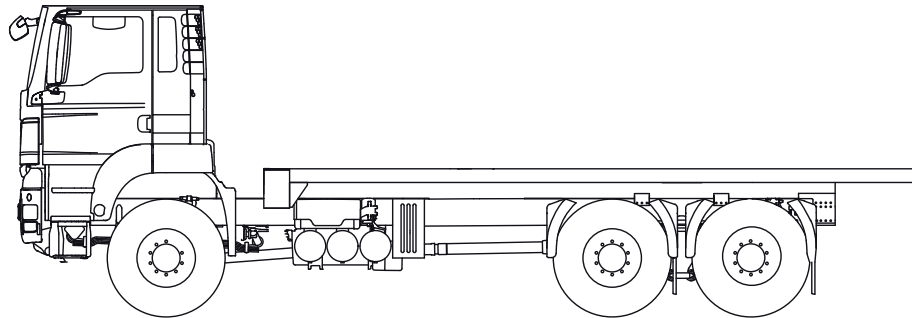

- ▶ Remove all interfering components from the vehicle. These may include:
  - rear lights,
  - reversing lights,
  - license plate,
  - spare wheel holder,
  - pallet carrier,
  - parts of the vehicle exhaust.
- ▶ Store the removed components in a secure, dry place.

Components that are not compatible with your **PALFINGER Tail Lifts** tail lift may not be reinstalled.

- ▶ Consult your vehicle maker to find alternative solutions for incompatible components.

## 6.2 Creating cutouts for the lifting mechanism (optional)

For most applications you will not need any special cutouts for the lifting mechanism. If this is necessary, however, you can obtain the dimensions for the cutouts from the general installation diagram or the attachment report (attachment diagram) from **PALFINGER Tail Lifts**.

- ▶ Transfer the dimensions or the lifting mechanism cutouts from the attachment diagram to the vehicle chassis.
- ▶ Create the cutouts according to the attachment mounting diagram and reinforce them.
- ▶ Seal the blank body parts with rust protection and repaint them. Observe the vehicle manufacturer's superstructure guidelines.

## 6.3 Reinforcing rear cross-member (optional)

Your truck's rear cross-member must be rated for your ordered type of **PALFINGER Tail Lifts** tail lift. Your vehicle's rear cross-member should be able to bear approximately twice the rated load of your **PALFINGER Tail Lifts** tail lift (e.g. with a 1000K tail lift around 2000 kg). If the rated load of the rear cross-member is insufficient for the ordered **PALFINGER Tail Lifts** tail lift, you may have to reinforce it.

## 6.4 Preparing vehicles with box bodies

### Mounting the sealing system

A sealing system can be ordered from **PALFINGER Tail Lifts** and pre-installed for vehicles with box bodies. The sealing system is mounted according to the special assembly instructions supplied.

### Box bodies with doors

To avoid damage to box body doors, you must attach spacers and bridging profiles. You must then abut the platform to the superstructure end with the bridging profile when the doors are open.

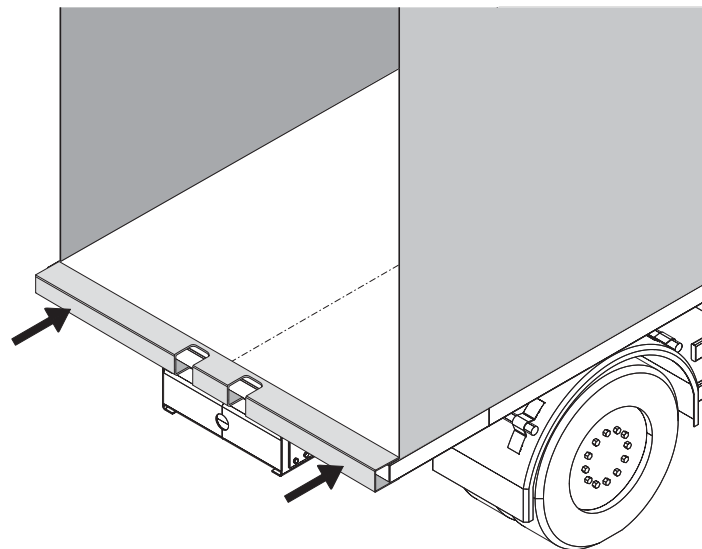

- ▶ Prepare the spacers for the lifting mechanism area (if necessary).
- ▶ Fix the spacers to the door.
- ▶ Create a bridging profile (e.g. a square tube with rounded edges 60x40x3).
- ▶ Mount the bridging profile over the entire loading area width.

## 7 Installing lifting mechanism

There are two options for mounting the lifting mechanism:

- Installation with installation aids (see chapter 7.1 on page 24)
- Installation with mounted platform (see chapter 7.2 on page 33),

### 7.1 Installation with installation aids

To assist in the installation of the lifting mechanism of your **PALFINGER Tail Lifts** tail lift, you can on request obtain special installation aids. This installation aids support you in mounting the lifting mechanism. The following steps are required when installing with installation aids:

- position and fix the installation aids on the vehicle chassis (see chapter 7.1.1 on page 24)
- position lifting mechanism under the vehicle (see chapter 7.1.2 on page 25),
- bolt lifting mechanism to installation aids (see chapter 7.1.3 on page 26),
- position the stand tube (see chapter 7.1.4 on page 27),
- fix lifting mechanism with console plates to vehicle chassis (see chapter 7.1.5 on page 27),
- mount hydraulic unit (see chapter 7.1.6 on page 32),
- remove installation aids (see chapter 7.1.7 on page 32).

#### 7.1.1 Positioning and fixing the installation aids on the vehicle chassis

#### **⚠ CAUTION**

##### **Risk of falling equipment!**

If you incorrectly position the installation aids or do not fix it correctly, the lifting mechanism may fall and cause personal injury or material damage.

► Make sure that the installation aids are correctly positioned and properly fixed.

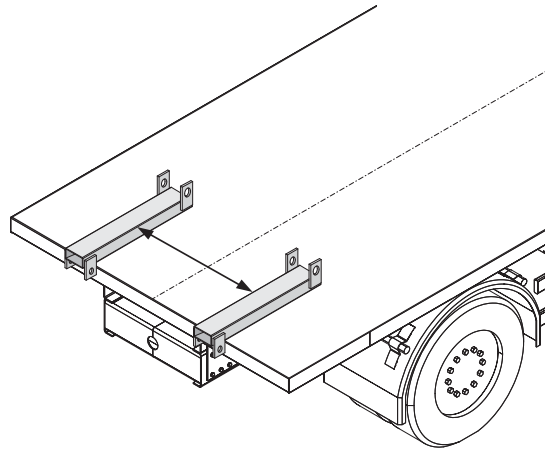

- ▶ Lay the installation aids on the loading area.
- ▶ Align the installation aids on the loading area. Refer to the dimensions in the general installation diagram.
- ▶ Securely fix the installation aids to the vehicle chassis with, for example, screw clamps.

### 7.1.2 Positioning lifting mechanism under the vehicle



- ▶ Raise the lifting mechanism with suitable lifting equipment such as a forklift truck or trolley jacks, for example.
- ▶ Carefully position the lifting mechanism under the vehicle.
- ▶ Detach the cables and hoses and feed them through the openings provided in the vehicle chassis.
- ▶ Carefully raise the lifting mechanism and move it into the installation position.
- ▶ Maintain the installation position with the lifting equipment until the lifting mechanism is finally fixed to the vehicle chassis.

### 7.1.3 Bolting the lifting mechanism to the installation aid

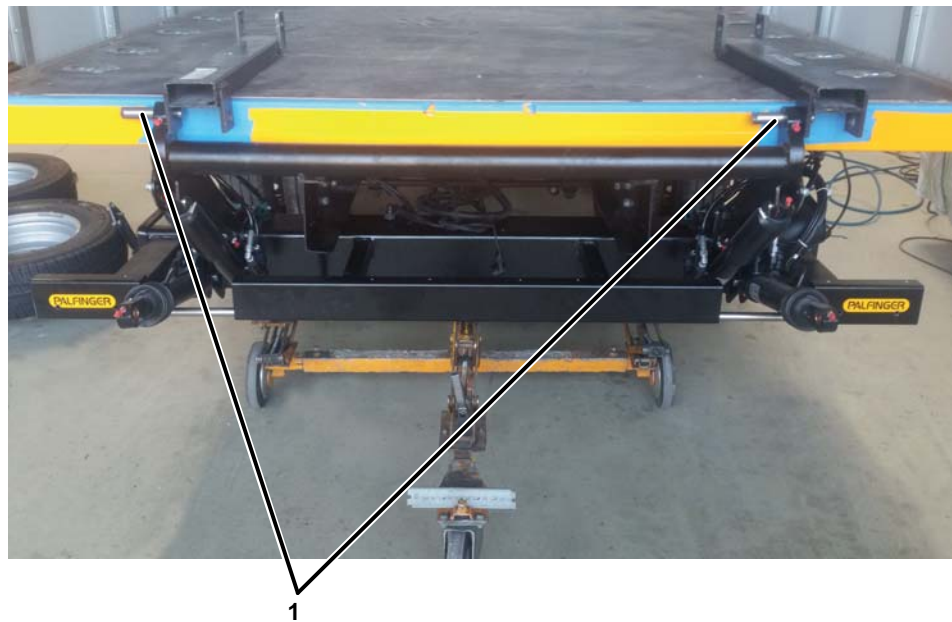

- ▶ Make sure that the lifting mechanism is in its final installation position.
- ▶ It may be necessary, for example if a sealing system is present, to attach spacers to ensure correct spacing between the control rod and vehicle chassis.
- ▶ Secure the lifting mechanism with screw clamps to the vehicle chassis.
- ▶ Lay the cables and hoses under the vehicle chassis.
- ▶ Bolt the lifting mechanism to the installation aid (1) and check the alignment to the vehicle body. The control rod must be lie flush on both sides of the rear cross-member.

### 7.1.4 Positioning the stand tube



- ▶ Adjust the stand tube height according to the general installation diagram. Ensure the greatest possible ground clearance and the free movement of all components.
- ▶ Move the stand tube into the horizontal position so that the top edge is parallel to the vehicle body.
- ▶ Secure the stand tube with screw clamps.

### 7.1.5 Fixing the lifting mechanism to console plates on the vehicle chassis

Attachment of the lifting mechanism to the vehicle chassis depends on the type of console plates used. The following console plates can be ordered from **PALFINGER Tail Lifts**:

- welded consoles
- bolted consoles

The installation sequence differs according to the type of console plates used.

The welded consoles are attached in advance by **PALFINGER Tail Lifts** to the lifting mechanism. The customer notifies **PALFINGER Tail Lifts** of the required distances between the consoles and these cannot be subsequently changed. The lifting mechanism is attached with the console plates to the vehicle chassis.

The bolted consoles are first adjusted on the lifting mechanism to the chassis size and then fixed. Together with the lifting mechanism, they are then attached to the vehicle chassis. The long holes in the bolted consoles make transverse adjustments possible.

To fix the lifting mechanism with welded consoles to the vehicle chassis, proceed as follows:

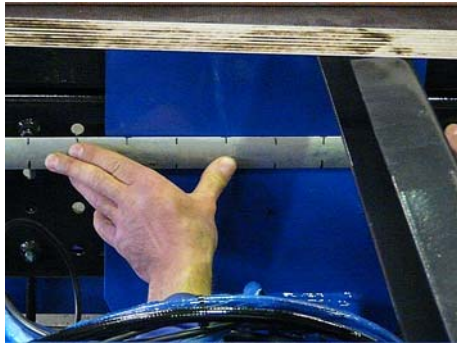

- ▶ Mark the following holes on the console plate. Observe the general installation diagram and vehicle manufacturer's box body mounting guidelines. Above all, note the number, position and diameter of drill holes.



- ▶ Drill the holes in the console plates.



- ▶ Bolt the console plates to the vehicle chassis. In the process, note the tightening torques in the general installation diagram and in the table on page 29.

If it should become necessary to perform any welding work on the stand tube, strictly observe the following safety instruction:

### NOTICE

#### Risk of damage to slide-in unit by welding

If you should fail to remove the slide-in unit before starting any welding work on the stand tube, the slide-in unit may be damaged.

- ▶ Prior to performing any welding work on the stand pipe, always remove the slide-in unit.
- ▶ Take appropriate measures to protect the slide-in unit from possible damage due to welding.

Table 1: Tightening torques on the consoles

Type HLB	Bolts/consoles	Bolt type	Tightening torque
C 500 SD	<b>4</b>	<b>M14x1.5</b>	<b>190 Nm</b>
C 500 SPLD/SPRD			
C 750 SPL/SPR			
C 750 S			
C 500 LD			
C 750 L			
C 750 LX			
C 750 LG			
C 750 LD			
C 750 ML (PRO) - C 1000 ML (PRO)			
C 750 SPLD/SPRD	<b>6</b>	<b>M14x1.5</b>	<b>190 Nm</b>
C 1000 S			
C 1000 SB			
C 1000 SPL/SPR			
C 1000 LD			
C 1000 L			
C 1500 L			
C 1500 ML PRO			
C 1500 S - C 2000 S	<b>10</b>	<b>M14x1.5</b>	<b>190 Nm</b>
C 1500 LX - C 2000 LX			
C 1500 LB			
C 1500 SZ			
C 2000 LZ			
C 1500 SK - C 2000 SK			
C 2000 L - C 2500 L			
C 2000 LK			
C 2000 LX PTG			
C 2500 S			
C 2500 SK	<b>10</b>	<b>M16x1.5</b>	<b>310 Nm</b>
C 3000 S	<b>14</b>	<b>M14x1.5</b>	<b>190 Nm</b>

To fix the **lifting mechanism with bolted consoles** to the vehicle chassis, proceed as follows:

### NOTE

We recommend installation of the bolted consoles to the vehicle chassis before positioning of the lifting mechanism under the vehicle.

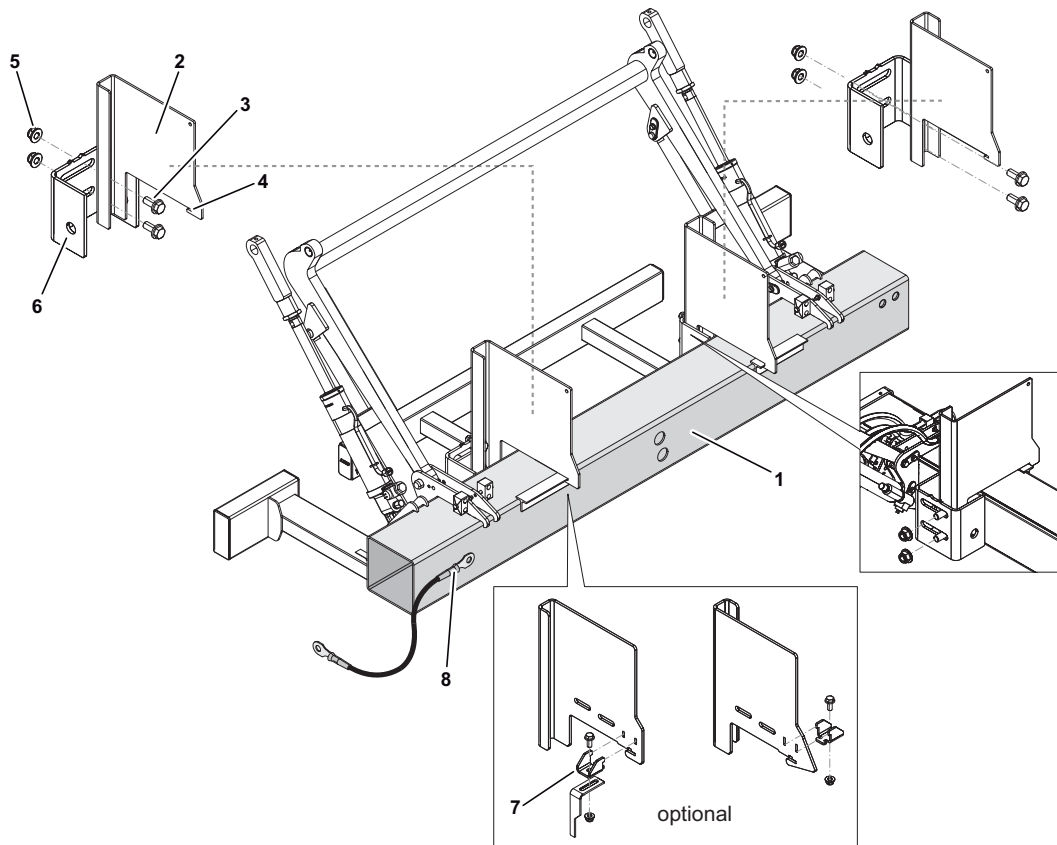

- |                        |                                  |
|------------------------|----------------------------------|
| <b>1</b> Stand tube    | <b>5</b> Hex. nuts               |
| <b>2</b> Console plate | <b>6</b> U-section               |
| <b>3</b> Bolts         | <b>7</b> Locking clamps (option) |
| <b>4</b> Hooks         | <b>8</b> Ground cable (option)   |

- ▶ **Optional:** Connect the locking clamps (7) to the console plate (2).
- ▶ Thread the console plates (2) with the bolts (3) and the hook (4) into the mountings on the stand tube (1).
- ▶ Turn the hex. nuts (5) on the bolts (3) and thus fix the console plate (2) and the U-section (6).
- ▶ Align the two console plates corresponding to the frame width and pretighten the hex. nuts.

- ▶ Mount the lifting mechanism as described in section „Installing lifting mechanism“ from page 24.
- ▶ Then precisely align the console plates (2) with respect to height and width to the chassis.
- ▶ Fix the console plates to the vehicle chassis and tighten the hex. nuts (5).
- ▶ **Optional:** Screw the locking clamps (7) by means of the hex. screw and nut to the stand tube (1).
- ▶ Note the following tightening torques.

Table 2

Bolts	Tightening torque
Bolt M20x1.5 - St10.9	400 Nm
Bolt M14x1.5 - St10.9	190 Nm
Bolt M10 - St8.8	50 Nm

The bolts must be regularly retightened regularly:

- after 3 weeks in operation
- after 3 months in operation
- check and if necessary retighten half-yearly

If the battery cable is not directly connected to the battery and the ground runs over the vehicle chassis, it may be necessary to fabricate a ground cable from the delivered cable lugs and protective caps.

#### **NOTE**

Before connecting the ground cable, find out from the vehicle maker whether this is possible.

- ▶ Cut off the required length of cable from the supplied battery cable.
- ▶ Keep the ground cable (8) as short as possible and attach it to the ground screw provided on the stand tube.
- ▶ Before lifting the platform, make sure that the solenoid valves on the lift cylinder can move freely at the U-section (6) of the bolted console. Otherwise you must turn the coil on the solenoid valve through 90°.

### 7.1.6 Installing the hydraulic unit (option)

The installation of your hydraulic unit depends on the selected type. Three types are available:

- slide-in unit
- turning unit
- box unit

The hydraulic unit is normally premounted by **PALFINGER Tail Lifts**. If request, you can also obtain a box unit with long cables and hoses. You can then mount this box unit at any position at any position under the vehicle. If the cables and hoses are too long, you must bundle them and fix them under the vehicle.

### 7.1.7 Removing the installation aid

#### **ATTENTION**

#### **Risk of damage to components!**

As there is still too little oil in the lift cylinders, the control rods can swing out in an uncontrolled fashion, thus damaging the lifting mechanism.

- ▶ Carefully fold down the control rods.



- ▶ Remove the pins between the control rods and the installation aids and carefully fold the control rods down.
- ▶ Release the screw clamps with which the installation aids are fixed to the vehicle chassis.
- ▶ Remove the installation aids from the vehicle chassis.

## 7.2 Installation with attached platform

The following steps are required when installing with premounted platform:

- position lifting mechanism under the vehicle (see chapter 7.2.1 on page 33),
- mount the platform on the lifting mechanism (see chapter 7.2.2 on page 34),
- mount auxiliary device (see chapter 7.2.3 to page 34),
- position and fix platform (see chapter 7.2.4 on page 35),
- install lifting mechanism (see chapter 7.2.5 on page 36),
- remove auxiliary device (see chapter 7.2.6 on page 36).

### 7.2.1 Positioning lifting mechanism under the vehicle

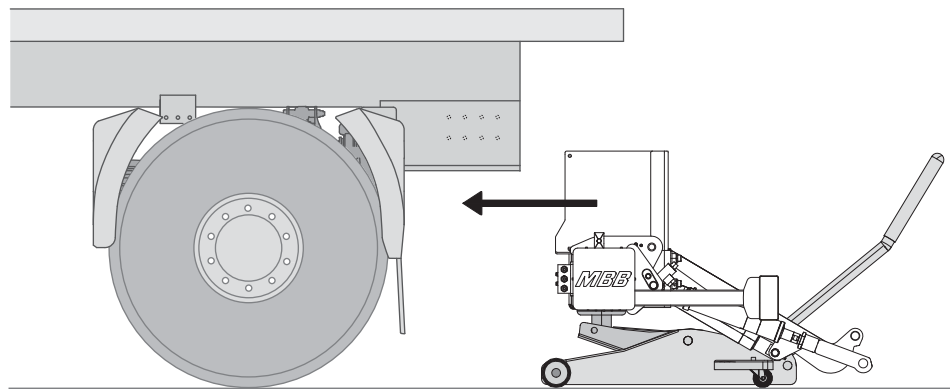

- ▶ Raise the lifting mechanism with suitable lifting equipment such as a trolley jack, for example.
- ▶ Carefully position the lifting mechanism under the vehicle.

## 7.2.2 Mounting the platform on the lifting mechanism

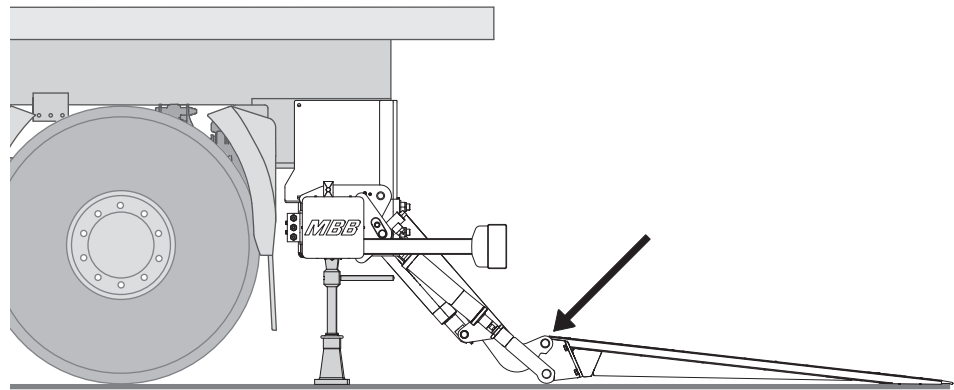

- ▶ Mount the platform on the lifting mechanism.
- ▶ Bolt the platform to the control rod without the tilt cylinders. Use the spacers delivered with the product to align the platform to the body.

## 7.2.3 Mounting auxiliary device

### CAUTION

#### Risk of falling equipment!

If you incorrectly position the auxiliary device or do not fix it correctly, the lifting mechanism with the platform may fall and cause personal injury or material damage.

- ▶ Make sure that the auxiliary device has a sufficient load bearing capacity to bear the lifting mechanism with platform.
- ▶ Make sure that the auxiliary device is correctly positioned and properly fixed.

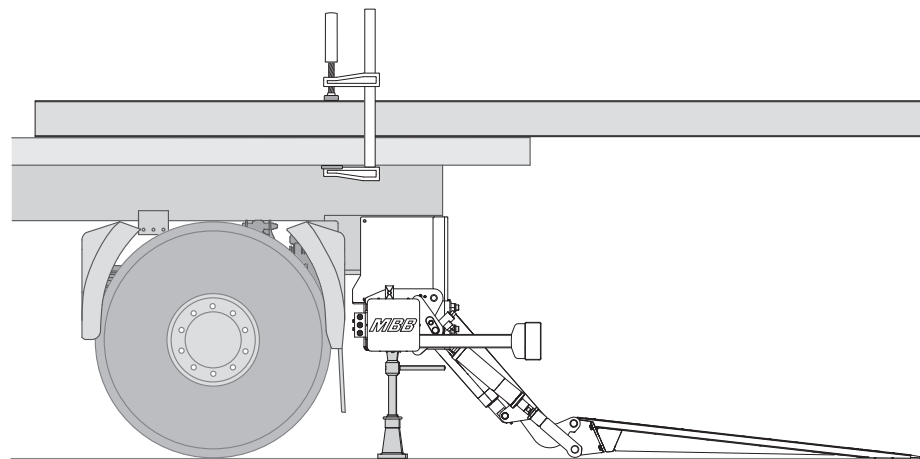

- ▶ Place two straight steel bearers of sufficient length on the load area between the control rod arms and vehicle body wall.

- ▶ Align the auxiliary device to the load area and fix it securely to the vehicle chassis with, for example, screw clamps.
- ▶ Ensure that the auxiliary device at least correspondingly projects above the platform height at the back.

#### 7.2.4 Positioning and fixing the platform

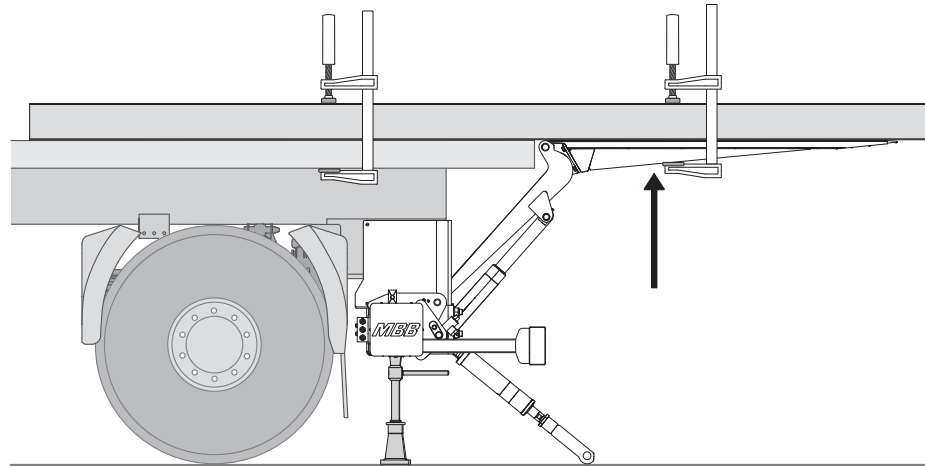

- ▶ Carefully raise the platform under the auxiliary device and align it with the body.
- ▶ Make sure that the control rod heads rest up against the rear wall apron. Observe the relevant installation diagram.
- ▶ Fix the platform securely to the auxiliary device. For this purpose, use appropriately rated screw clamps and additionally secure the platform against falling with trestles, for example.
- ▶ Detach the cables and hoses and feed them through the openings provided in the vehicle chassis.
- ▶ Carefully raise the lifting mechanism and move it into the installation position.
- ▶ Maintain the installation position with the lifting equipment until the lifting mechanism is finally fixed to the vehicle chassis.

### 7.2.5 Installing lifting mechanism

- ▶ Proceed with the installation of the lifting mechanism from step „Positioning the stand tube“ on page 27.
- ▶ Fix the lifting mechanism according to the type of console plates used (see chapter 7.1.5 on page 27).
- ▶ For this purpose, use the adjustment gauge indicated on the installation diagram.
- ▶ Bolt the tilt cylinders to the platform (see chapter 9.3 on page 44).

### 7.2.6 Removing auxiliary device

- ▶ Release the screw clamps fixing the auxiliary device to the vehicle chassis.
- ▶ Remove the auxiliary device from the vehicle chassis.

## 8 Establishing electrical connections

To electrically connect your tail lift, use the supplied **PALFINGER Tail Lifts** electrical circuit diagram and the vehicle maker's attachment guidelines. You will find the respective **PALFINGER Tail Lifts** electrical circuit diagram in the electrical unit on the circuit board.

The following steps are required:

- establish connection to vehicle battery (see chapter 8.1 on page 37),
- install and connect optional control unit (see chapter 8.2 on page 39),
- mount control panel holder (see chapter 8.3 on page 40),
- connect optional hand cable switch (see chapter 8.4 on page 40),
- connect optional remote control (see chapter 8.4 on page 40).

### 8.1 Establishing connection to vehicle battery

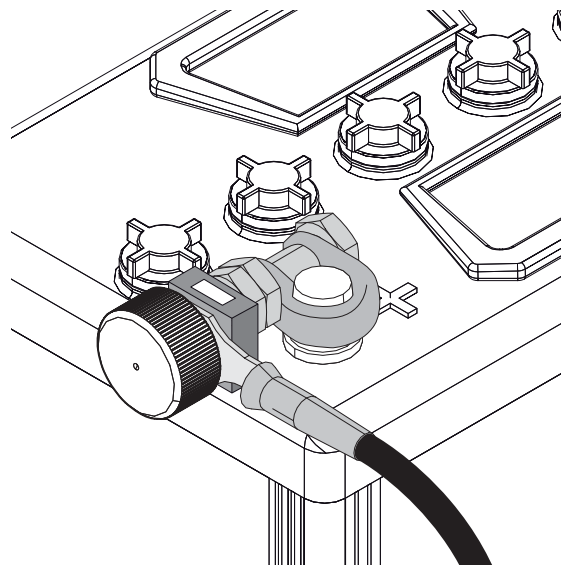

- ▶ Lay the plus battery cable to the battery. Shorten as required.
- ▶ Attach the cable lug to the battery cable.
- ▶ Attach the main fuse with the cable lug and connect the battery cable to the battery plus terminal.

Optional:

- ▶ Run the ground cable to the battery. Shorten as required.
- ▶ Crimp the cable lug and mount it on the battery's minus terminal.

With vehicles with preinstalled ETMA interface

- ▶ Plug the plus and minus cables into the mating plugs.

**NOTE**

With hazardous goods vehicles, the ground cable must be connected to the battery or in accordance with the respective vehicle manufacturer's guidelines for mounting attachments.

## 8.2 Installing and connecting the control unit

The optional control unit must be mounted in a suitable location in the driver's cab. If a control unit is already present in the vehicle, you must connect your **PALFINGER Tail Lifts** tail lift according to a special circuit diagram, which you can obtain from **PALFINGER Tail Lifts**.

### NOTE

Connection of the control device must not take place until the electrical connection of the plus and minus cable has taken place.

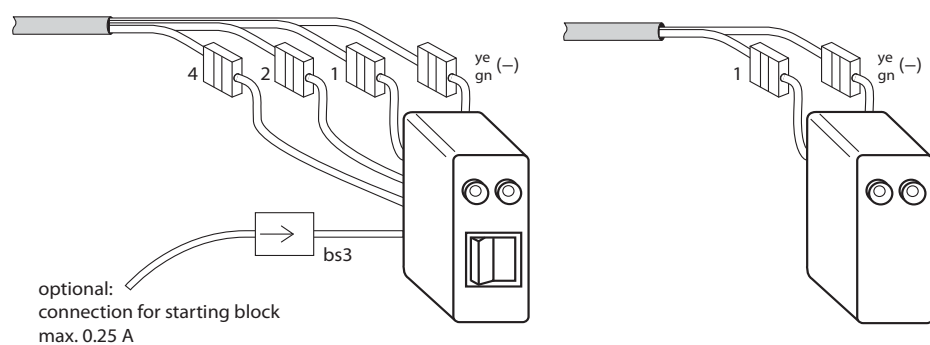

- ▶ Run the cable for the control unit to the driver's cab.
- ▶ Select a suitable location on the dashboard in the driver's cab.
- ▶ Establish an electrical connection as per the **PALFINGER Tail Lifts** circuit diagram.
- ▶ Mount the control unit on the dashboard.

### 8.3 Mounting the control panel holder



- Fix the control panel holder with screws or weld it in position as per the **PALFINGER Tail Lifts** installation diagram.

### 8.4 Connecting the manual cable switch/remote control (optional)

A manual cable switch or a remote control are optionally available with your **PALFINGER Tail Lifts** tail lift.

#### **NOTE**

When installing a manual cable switch, you must attach the cable with socket under the vehicle loading area so that the cable can be connected to the manual cable switch.

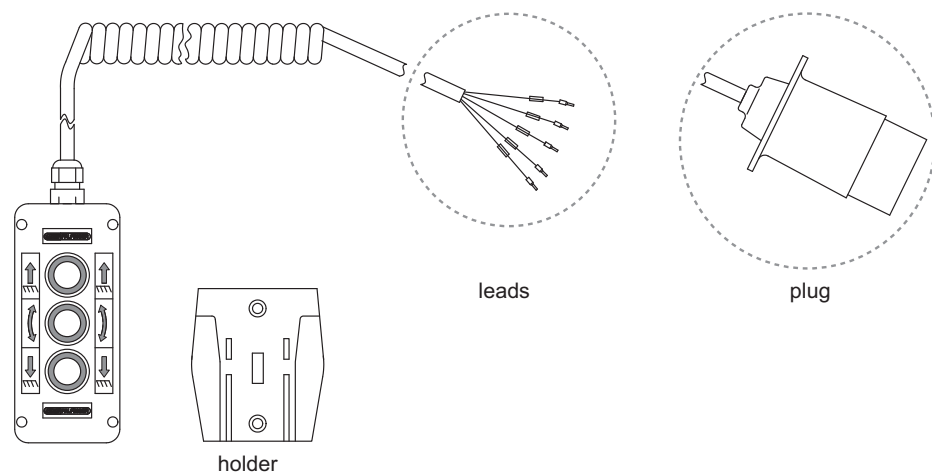

Lead	Pin	Leads manual cable switch	
		with 3 buttons	with 2 buttons
1	4	white	-
2	5	green	-
3	6	brown	yellow
4	3	yellow	red
ye/gn	2	red	green/black

Table: 3 Socket connection

- ▶ Select a suitable place for mounting the socket under the vehicle loading bay. A fixing option is provided on most control panel holders.
- ▶ Mount the socket.
- ▶ Connect the cable from the manual cable switch in the terminal box in accordance with the **PALFINGER Tail Lifts** wiring diagram.
- ▶ Find a suitable and secure storage location for the manual cable switch. Operation of the manual cable switch only permissible from the marked position on the platform.

**NOTE**

If the manual cable switch is on the attachment, this is not supplied with a socket but is connected via a junction box with the wire from the circuit board. The manual cable switch is then fixed and cannot be unplugged. The required circuit diagram is available on request from **PALFINGER Tail Lifts**.

**Wireless remote control** The receiver for a wireless remote control is prewired and only has to be clipped onto to slot J31 on the circuit board and connected to ground. You will then have to attach the receiver to the stand tube. The receiver and the wireless remote control are preadjusted so that they are immediately operational. A detailed description is supplied with the wireless remote control.

## 9 Installing and connecting the platform

If you have installed your **PALFINGER Tail Lifts** tail lift with premounted platform (see chapter 7.2 on page 33), you can skip the first three steps in platform installation and begin with step „Adjusting the tilt cylinder“ on page 47.

The following steps are required:

- bring up the platform with the lifting equipment and position it (see chapter 9.1 on page 42)
- bolt the platform to the control rod (see chapter 9.2 on page 43),
- bolt the platform to the first tilt cylinder (see chapter 9.3 on page 44),
- adjust the tilt cylinder (see chapter 9.4 on page 47),
- bolt the platform to the second tilt cylinder (see chapter 9.5 on page 48)
- connect plug for foot-operated switch and Warnfix (see chapter 9.6 on page 48),
- install tilt sensor (see chapter 9.7 on page 49).

### 9.1 Moving up and positioning platform

This step is only required if you have installed your **PALFINGER Tail Lifts** tail lift with the supplied installation aids (see chapter 7.1 on page 24).



- ▶ Raise the platform with a suitable lifting equipment, e.g. a forklift truck and bring the platform up to the truck tailgate.



- ▶ Carefully raise the platform and move it into the installation position at the truck tailgate.
- ▶ Maintain the installation position with the lifting equipment until the platform is bolted to control rod and tilt cylinders.

## 9.2 Bolting the platform to the control rod

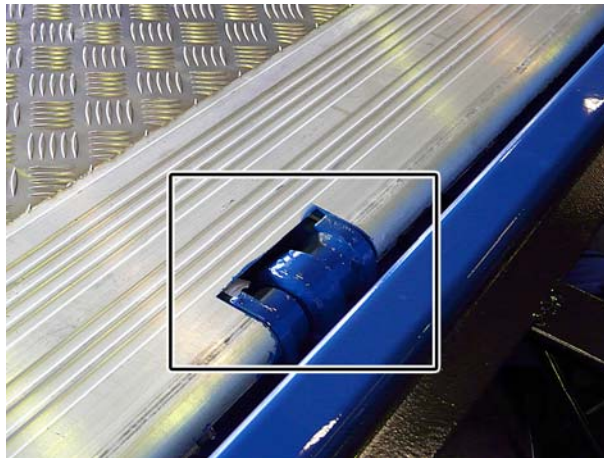

- ▶ Make sure that the platform is in its final installation position.
- ▶ Grease the two bearing pins.
- ▶ Bolt the platform to the control rod. Use the spacers delivered with the product to align the platform to the body.

### 9.3 Bolting the platform to the first tilt cylinder

Depending on your tail lift model, you will need to bolt one or two tilt cylinders to the platform. If your tail lift is equipped with two tilt cylinders, you should initially only bolt one tilt cylinder to the platform.

#### Inserting the air filter (option)

Depending on the hydraulic unit manufacturer, you will have to remove the plug screw of the oil tank and replace it with an air filter, before you can bolt the platform to the first tilt cylinder.

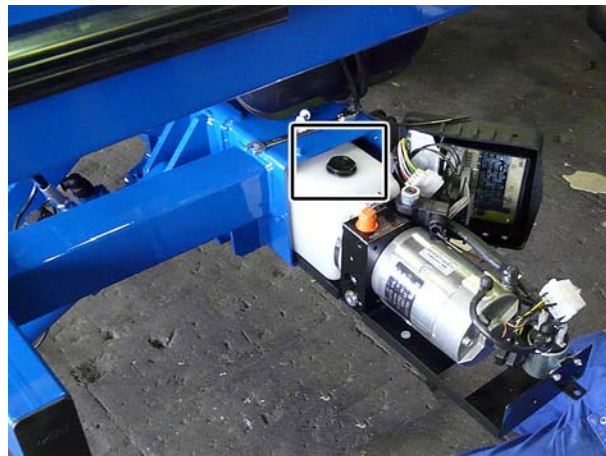

- ▶ Open the sealing cap on the hydraulic unit and carefully pull the hydraulic unit out.
- ▶ Remove the oil tank screw plug.



- ▶ Insert the enclosed air filters.

- ▶ Slide the hydraulic unit back in, close the sealing cap and secure this with the clip.
- ▶ Then check whether the hydraulic unit is correctly connected. Refer to the enclosed hydraulic circuit plan.

**Bolting the platform  
to the tilt cylinder**



- ▶ Detach the bellows hose clamp and slide the bellows down.
- ▶ Turn the rod end of the tilt cylinder on the piston rod as far as it will go.
- ▶ Adjust the tilt cylinder length so that it possible to easily bolt the tilt cylinder to the platform.

**NOTE**

To do this actuate the rotary switch for "Open" or "Close", at the same time holding the tilt sensor b15 or b16 with the cable pointing downwards (not necessary with "Basic" controller).

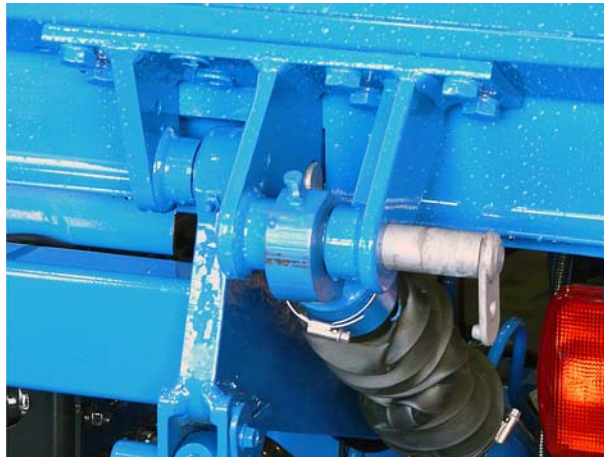

- ▶ Grease the pin and bolt the tilt cylinder to the platform. Use the spacers delivered with the product to align the platform to the body.
- ▶ During the assembly, make sure that the lubrication nipple on the piston rod end is oriented upwards and that the PALFINGER logo is not upside down.

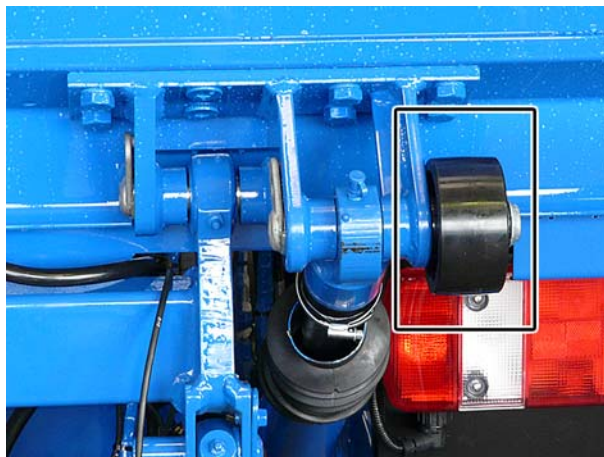

- ▶ Mount the floor roller and secure the pin.
- ▶ Move the lifting mechanism via the lift cylinder to the upper stop.
- ▶ Remove the lifting equipment.

## 9.4 Adjusting the tilt cylinder

### NOTE

At the desired end position of the platform, the tilt cylinder must be extended to the stop.



- ▶ Close the platform to the extent possible. The tilt cylinder is extended to the stop.
- ▶ Release the tilt cylinder via the "Open" rotary switch.
- ▶ Move the platform to the desired end position. To do this, turn the piston rod with a wrench.
- ▶ Repeat the adjustment process if required, until the platform has reached the desired position.



- ▶ Release the tilt cylinder by opening the platform.
- ▶ Tighten the locking nut on the piston rod as per the **PALFINGER Tail Lifts** installation diagram.
- ▶ Pull the bellows back over the piston rod and secure it with the clip.

## 9.5 Bolting the platform to the second tilt cylinder (apart from the types DUO and 1000 E)

If you have bolted the platform to the first tilt cylinder, you can now bolt it to the second tilt cylinder. The second tilt cylinder is installed as described in chapter 9.3 on page 44.

## 9.6 Connecting plug for foot-operated switch and Warnfix



- ▶ Detach the strain relief.
- ▶ Pull the cables for the foot-operated switch and the Warnfix from the platform.
- ▶ Connect the plugs with the plugs that come from the control rod. Make sure that colour-coding of the plugs match.
- ▶ Stow the connected cables again in the tailgate.
- ▶ Reconnect the strain relief.
- ▶ Make sure that the attached cables are carefully laid and securely fastened. Make sure that bending lengths are sufficient.

## 9.7 Installing tilt sensors



- ▶ Mount the tilt sensors as shown on the right of the platform.
- ▶ Feed the cables through the openings. Bundle up cables that are too long and secure these with cable binders.
- ▶ Connect the cables and pull them back to the right length.
- ▶ Fix the sensor to the platform.
- ▶ Observe the torque of 5 Nm.
- ▶ Lay a loop for strain release.
- ▶ Secure the cables with cable binders.

## 10 Adjusting and testing installed tail lift

When you have installed your **PALFINGER Tail Lifts** tail lift, you must then adjust it and test that it is functioning properly. This entails the following jobs:

- opening/closing platform and setting tilt switch **b13** (see chapter 10.1 on page 50),
- air bleeding hydraulic cylinders (see chapter 10.2 on page 51),
- checking horizontal position on ground (see chapter 10.3 on page 51),
- performing oil level check (see chapter 10.4 on page 52),
- checking all screw connections (see chapter 10.5 on page 52),
- attaching warning strips, safety point decals (optional) and type plate (see chapter 10.6 on page 53),
- performing acceptance test as per test book (see chapter 10.8 on page 55).

### 10.1 Opening/closing platform and setting tilt switch **b13**

#### **NOTE**

When the tilt sensor **b15** is present on the lift arm of your tail lift, this adjustment is not required.

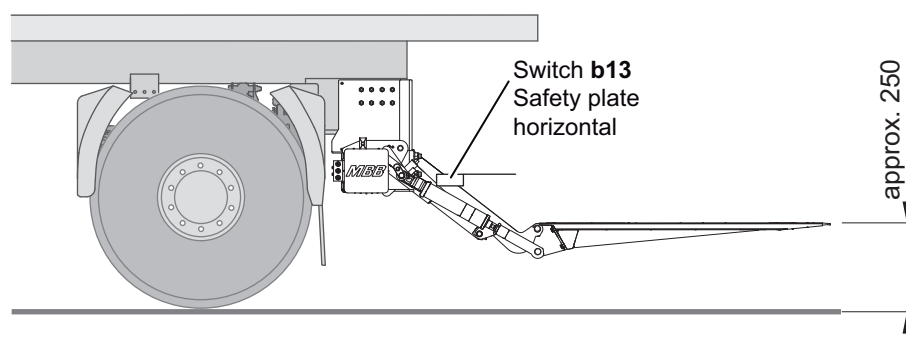

- ▶ Close the platform via the control panel
- ▶ Open the platform until it is approx. 250 mm above the ground.
- ▶ Release the screw on tilt switch **b13** on the right torsion arm.
- ▶ Adjust tilt switch **b13** so that it is horizontal.
- ▶ Retighten the screw on tilt switch **b13**.
- ▶ Observe the torque of 9 Nm.
- ▶ Fold back the safety plate.

## 10.2 Air bleeding the hydraulic cylinders

- ▶ Raise and lower the platform several times.
- ▶ Open and close the platform several times.

## 10.3 Checking horizontal position on ground

### NOTE

This test only has to be performed if tilt switch **b16** is provided.

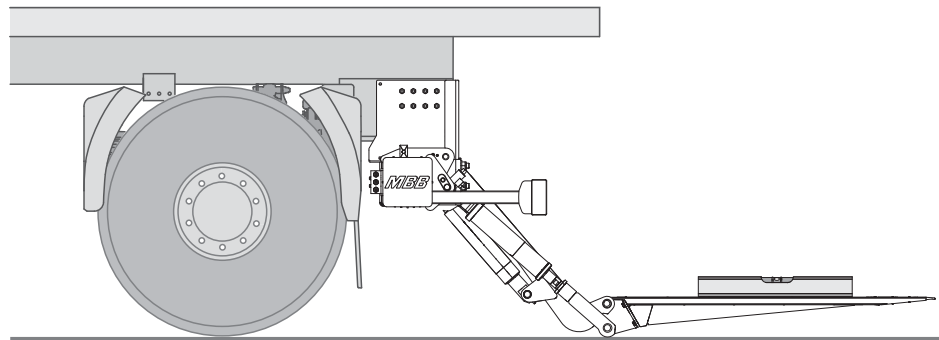

- ▶ Open and lower the platform until it sets down on the ground.
- ▶ Check that the platform rests horizontally on the ground.
- ▶ If the platform does not lie level, release the screw on tilt switch **b16**.
- ▶ Adjust tilt switch **b16** so that the platform rests level on the ground.
- ▶ Retighten the screw on tilt switch **b16**.
- ▶ Observe the torque of 9 Nm.

## 10.4 Performing an oil level check



- ▶ Lower the tail lift so that it rests on the ground.
- ▶ Open the sealing cap on the hydraulic unit and carefully pull the hydraulic unit out until the valve block is projecting.
- ▶ Check the oil level with the mark on the oil reservoir or with a dipstick.
- ▶ As required, top up with oil or drain the excess oil off (see chapter "Testing the oil level" in operating manual of your **PALFINGER Tail Lifts** tail lift).
- ▶ Slide the hydraulic unit back into the stand tube and fix the sealing cap.

## 10.5 Checking screw connections

- ▶ Study the **PALFINGER Tail Lifts** installation diagram.
- ▶ Obtain the required tightening torques for the screw connections from the **PALFINGER Tail Lifts** installation drawing.
- ▶ Make sure that all screw connections are secure.

## 10.6 Attaching warning strips, safety point decals (optional) and type plate

The scope of delivery of all **PALFINGER Tail Lifts** tail lifts includes two warning strips. The warning strips are mounted according to the enclosed "Installation instructions for warning strips" (drawing no. 92-597.99-00.00-00).

The safety point decals are only included in your scope of delivery if your tail lift is equipped with wireless remote control. In this case you will receive an installation diagram for the safety point decals (drawing no. 08-522.99-04.00-01).

- ▶ Mount the warning strips according to the enclosed assembly instructions on the **PALFINGER Tail Lifts** tail lift.
- ▶ If available, mount the safety point decals according to the supplied assembly instructions on the **PALFINGER Tail Lifts** tail lift.



- ▶ Clean and degrease the surface for the type plate at the bottom right of the platform.
- ▶ Glue the supplied type plate to the platform.
- ▶ Glue the test plaque on a prominent place.

## 10.7 Adjusting the pressure switch of the hydraulic support (C 750 L to C 1000 L)

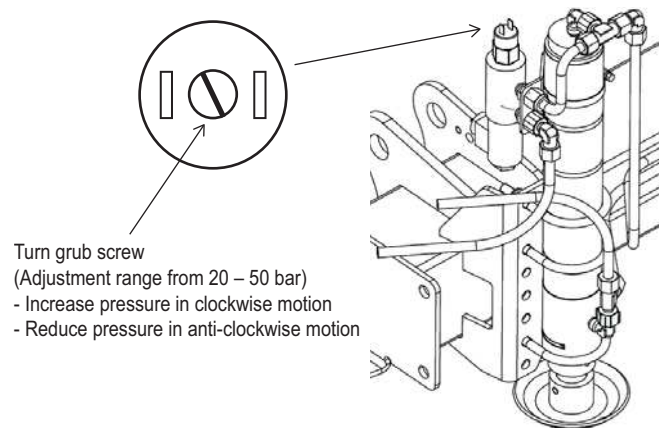

If the hydraulic support raises the vehicle too high or the props do not reach the ground, the pressure switch of the support can be adjusted.

The grub screw on the pressure switch must be turned for this purpose. To decrease the contact pressure of the props, turn the grub screw anti-clockwise one rotation.

To increase the contact pressure of the props, turn the grub screw clockwise one rotation.

After adjusting the contact pressure, check the adjustment by lowering the props. If the desired shut-off of the support is not provided, repeat the adjustment.

## 10.8 Performing acceptance test as per test book

- ▶ Perform initial commissioning in accordance with the test book.
- ▶ Enter the required details in the test book.
  - Company
  - Code
  - Installation company
  - Details of signatory
- ▶ It is essential that you enter the details on the operator and vehicle on page 3 as well as the form "Confirmation by the installation firm" on page 11 of the test book.

## 11 Index

### A

Abbreviations 7

Adjusting

tail lift 50

tilt cylinder 47

auxiliary equipment 13

### B

Bolting

platform to the control rod 43

platform to the tilt cylinder 44

platform to the tilt cylinders 44

### E

Enclosed documents 7

### F

Foot-operated switch

connecting plug 48

### H

Hydraulic circuit diagrams 58

### I

Installing

control unit 39

tilt sensors 49

Installing lifting mechanism

with installation aids 24

with platform 33

### M

Model line 14

### P

Personnel qualifications 9

Preparing

for installation 18

vehicle 20

### S

Safety instructions

before starting installation 11

during installation 12

general 11

initial commissioning 12

scope of delivery 14

Set tilt switch b13 50

**T**

## Tail lift

platform 17

standard 15

with bolted consoles 16

with welded consoles 16

## Tools 13

## Truck

with box body 20

**W**

## Warnings

layout 10

# 12 Hydraulic circuit diagrams

## 12.1 Standard tail lift with four cylinders

96-560.98-00.00-00

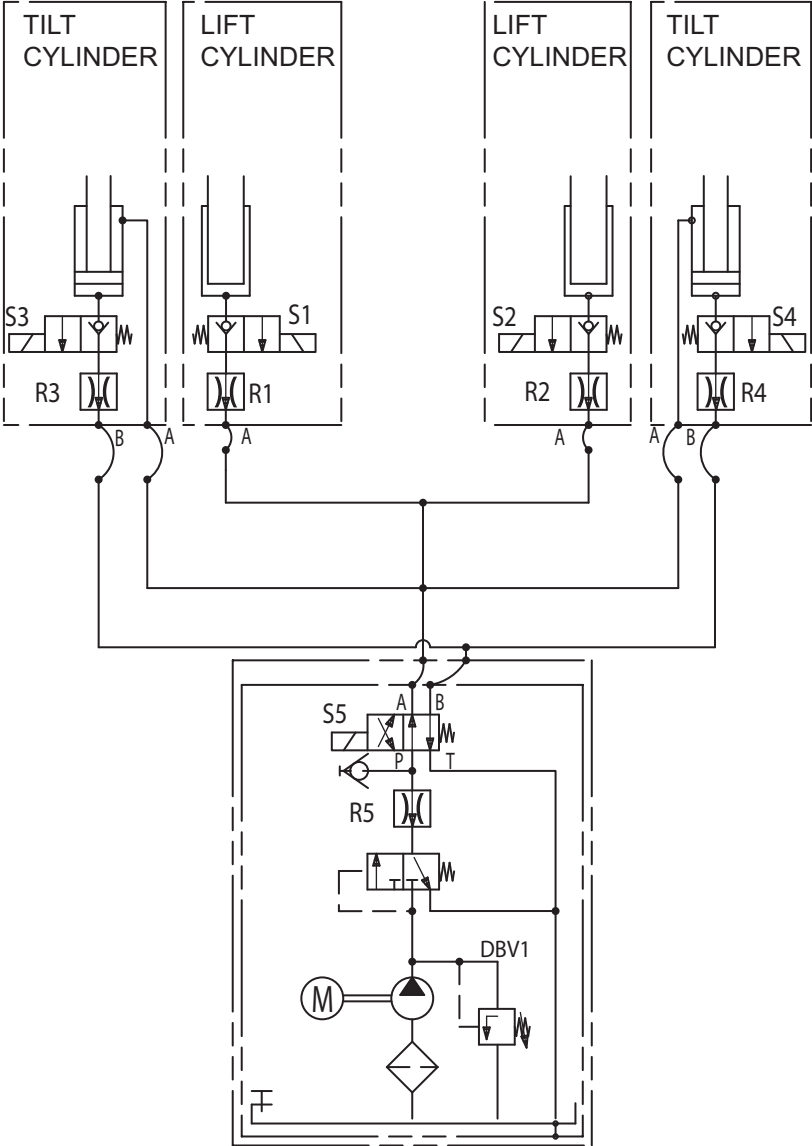

## 12.2 Standard tail lift with two cylinders

97-510.98-00.00-00

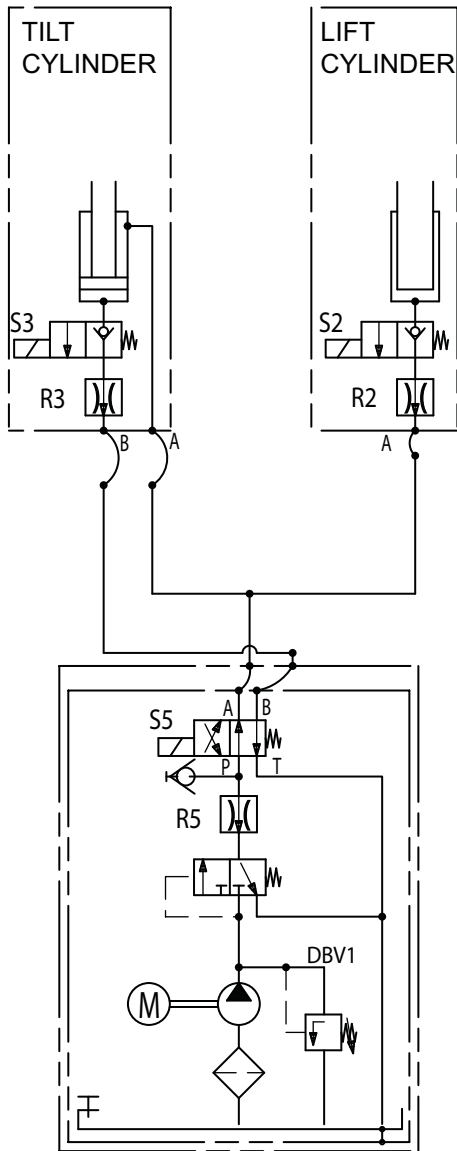

### 12.3 Standard tail lift with hydraulic support

96-524.98-01.00-00

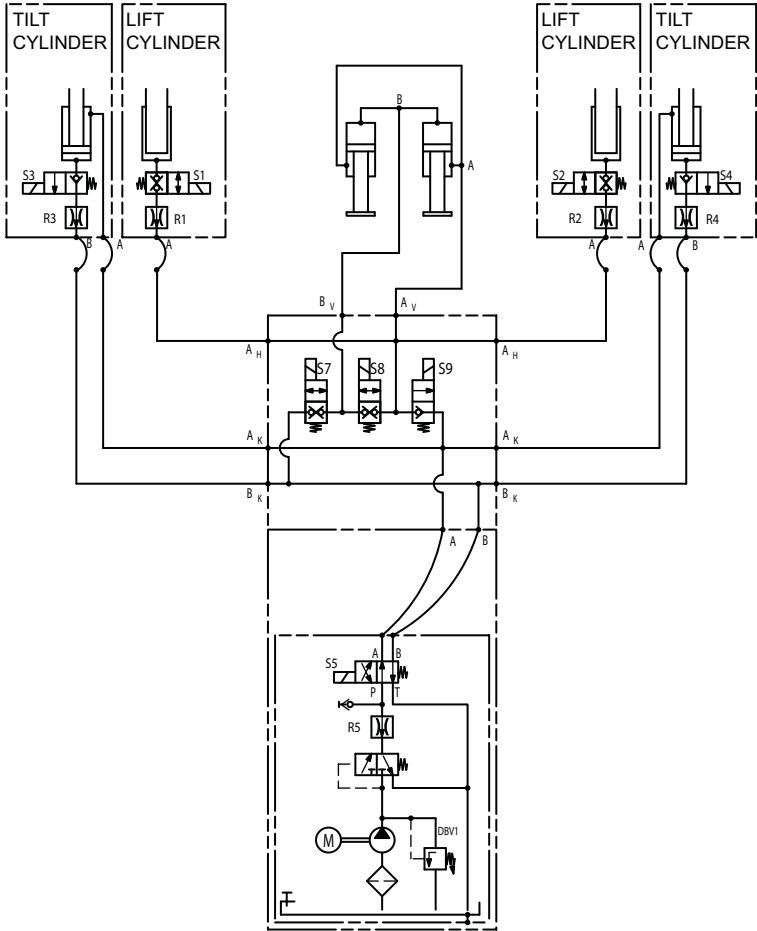

### 12.4 Tail lifts with hydraulic support MBB C 750 L – C 1000 L

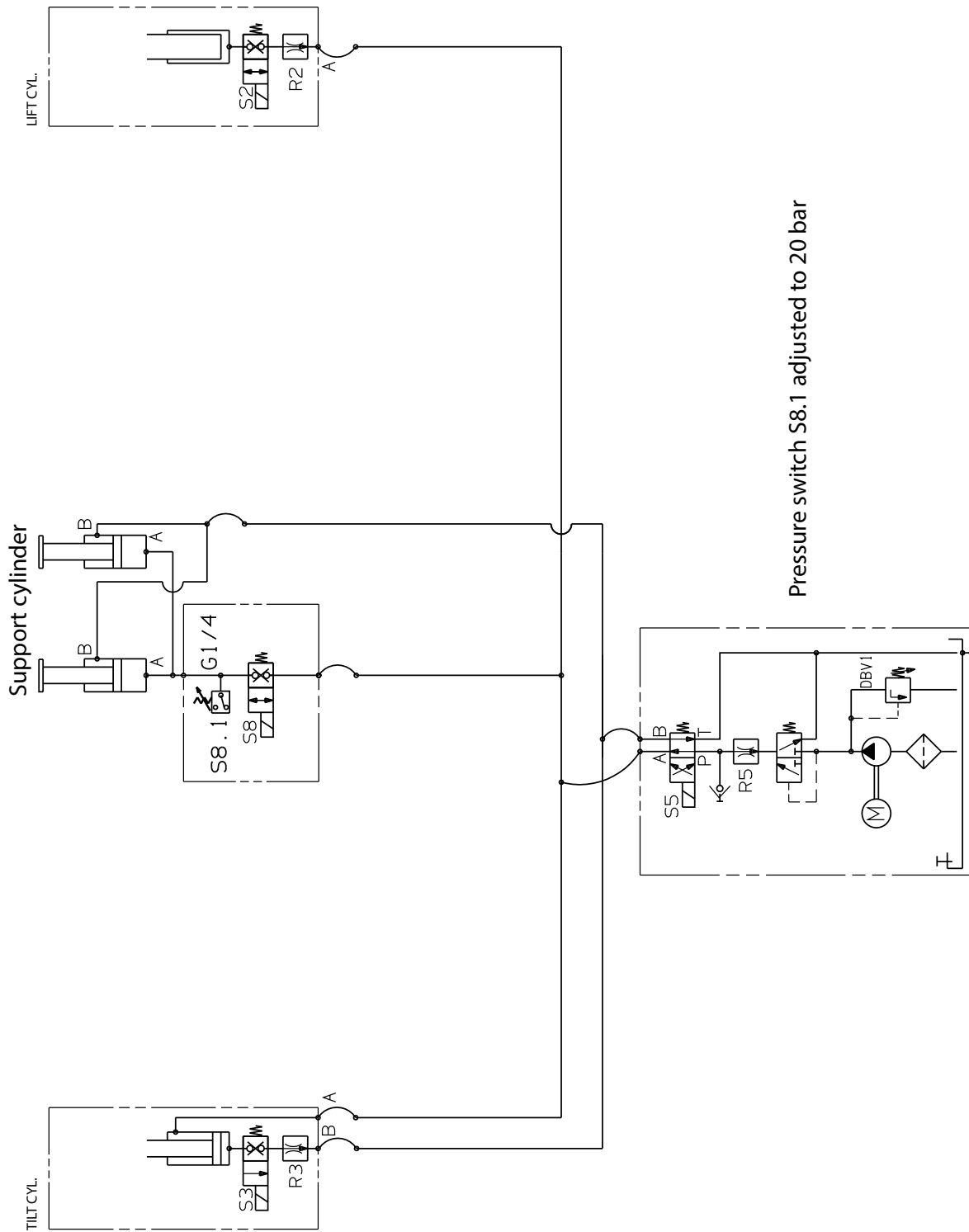

### 12.5 Standard tail lift with hydraulic under-ride protection

99-514.98-01.00-00/3

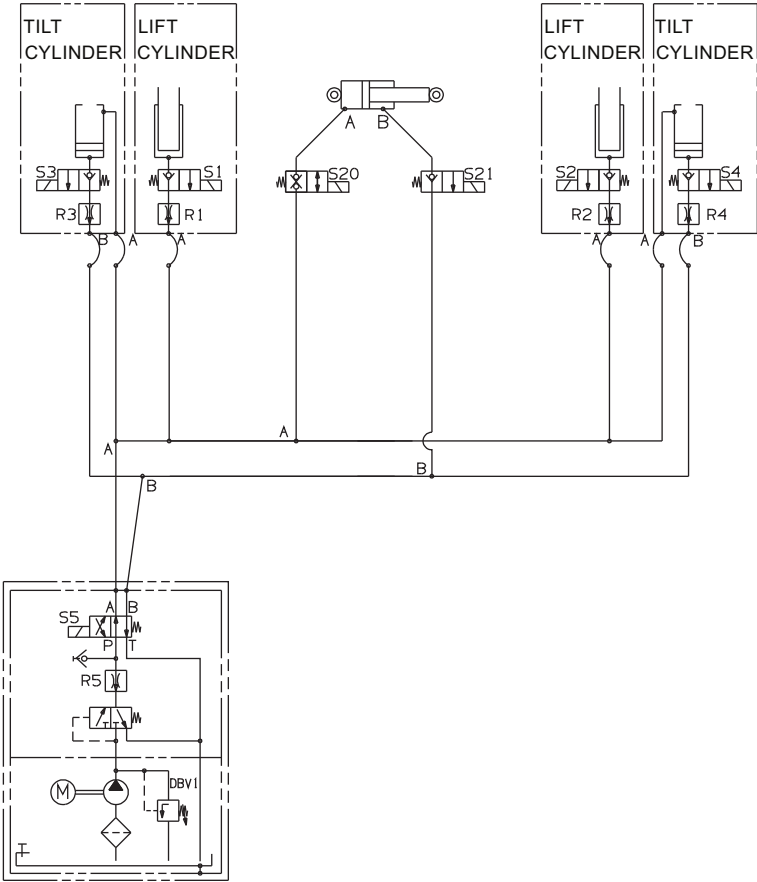



**PALFINGER Tail Lifts GmbH**

Fockestraße 53  
D-27777 Ganderkesee/Hoykenkamp  
Tel.: +49-4221 8530  
Fax: +49-4221 87536  
infombb@palfinger.com  
www.palfinger.com

**PALFINGER Hayons S.A.S**

Rue de l'Eglise  
F-61310 Silly en Gouffern  
Tel.: +33-2 33 12 44 00  
Fax: +33-2 33 12 44 01  
francemb@palfinger.com  
www.palfinger.com

**PALFINGER Tail Lifts s.r.o.**

Gogolova 18  
SK-85101 Bratislava  
Tel.: +421-252 636 611  
Fax: +421-252 636 612  
mbbsk@palfinger.com  
www.palfinger.com

**PALFINGER Tail Lifts Ltd.**

Bessemer Road  
Welwyn Garden City  
UK-Herts AL7 1ET  
Tel.: +44-01707 325571  
Fax: +44-01707 327752  
inforatcliff@palfinger.com  
www.palfinger.com

**PALFINGER TAIL LIFTS**

**OPERATING INSTRUCTIONS**

**TAIL LIFTS**





# **Operating Instructions**

**for**

## **PALFINGER Tail Lifts**

Standard Tail Lifts  
Retractable Tail Lifts  
Foldable Tail Lifts  
Column Lifts

# Table of Contents

<b>Table of Contents</b> .....	<b>4</b>
<b>About these Instructions</b> .....	<b>6</b>
Further Documentation .....	6
<b>Important Safety Information</b> .....	<b>7</b>
Proper Use .....	7
Qualification of Personnel .....	7
Safety Instructions in these Instructions .....	8
Observe the Following .....	8
<b>PALFINGER Tail Lifts– The Tail Lift</b> .....	<b>10</b>
<b>Scope of Delivery</b> .....	<b>11</b>
<b>How to Find Your Tail Lift Model</b> .....	<b>12</b>
<b>Model Overviews</b> .....	<b>14</b>
Standard Tail Lifts .....	14
Standard Tail Lifts .....	15
Standard Tail Lifts .....	16
Standard Tail Lifts with Electrical Cylinders .....	17
Retractable Tail Lifts .....	18
Retraction Equipment .....	19
Foldable Tail Lifts .....	20
Column Lifts .....	21
<b>Presetting the Tail Lift</b> .....	<b>22</b>
Setting the Ground Adjustment Timing .....	22
Presetting the Platform Tilt .....	22
Adjusting the pressure switch of the hydraulic stabilizer feet .....	23
<b>General Operation</b> .....	<b>24</b>
Switching on the Tail Lift .....	25
Extending the Stabilizer Feet at Your Vehicle .....	27
Retracting the Stabilizer Feet at Your Vehicle .....	28
Putting up or laying down the safety railing at the platform ..	28
Moving the Platform .....	31
Loading or Unloading the Platform .....	34
Switching off the Tail Lift .....	36
Driver's cab control unit .....	37

<b>Operating Elements .....</b>	<b>38</b>
Lateral Operating Element .....	38
Operation Using two Hand Cable Controls with three Pushbuttons, each .....	92
Optional Operating Method: Foot Control .....	98
Optional Operating Method: Hand Cable Control with two Pushbuttons .....	100
Optional Operating Method: Hand Cable Control with three Pushbuttons .....	102
Optional Operating Method: Hand Cable Control with four Pushbuttons for MBB C 750 SX .....	105
Optional Operating Method: Wireless Remote Control Unit (Standard) .....	108
Special Operating Elements .....	110
Special Operating Elements .....	112
Special Operating Elements .....	114
Programming a Key Code .....	116
<b>Service and Maintenance .....</b>	<b>120</b>
Maintenance Before Starting .....	123
Maintenance Depending on Usage Frequency .....	124
Monthly Maintenance .....	130
Quarterly or Semi-annual Maintenance .....	133
Annual Maintenance .....	133
Checks .....	138
<b>Eliminating Faults .....</b>	<b>139</b>
<b>Technical Data .....</b>	<b>156</b>
Load Diagrams .....	157
Hydraulic Diagrams .....	163
<b>Lubricants and Operating Media .....</b>	<b>178</b>
Recommended Hydraulic Oil Grades .....	178
Environment-friendly Oils .....	178
Recommended Lubricant Grease .....	178
<b>Available Accessories .....</b>	<b>178</b>
<b>Index .....</b>	<b>181</b>

## About these Instructions

These instructions contain important information to install, operate, and maintain the **PALFINGER Tail Lifts** tail lift in a safe and proper way, and to eliminate simple faults yourself.

- ▶ Before starting to work with the tail lift, read these instructions completely, particularly chapter „Important Safety Information“.

### Further Documentation

- Assembly instructions
- Assembly drawing
- Spare parts catalog (online)
- Test data booklet
- Assembly inspection report (on request)
- Brief operating instructions (optional)
- Supplement to operating instructions (optional)

## Important Safety Information

The **PALFINGER Tail Lifts** tail lift is manufactured according to state-of-the-art processes and approved safety standards. However, the risk of personal injuries and material damage exists if the following general safety instructions and the warnings prior to the work instructions given in this manual are not obeyed.

- ▶ Therefore, read these instructions thoroughly and completely before operating the tail lift.
- ▶ Store the instructions in such a way that all users have access to the instructions at any time.
- ▶ Always provide these operating instructions if you sell or rent out the vehicle with the tail lift.

## Proper Use

- ▶ Exclusively use the tail lift for loading and unloading goods. During loading and unloading, only the operator is allowed to travel on the lift.
- ▶ Observe all capacity limits as stated in the technical data. Proper use also means that you have read and understood these instructions, particularly chapter „Important Safety Information“.

Improper use is considered any use where the tail lift is used

- outside the application areas stated in these instructions,
- under operating conditions that deviate from the description in these instructions.

## Qualification of Personnel

The operation of the tail lift is only allowed for:

- personnel who has read and understood these instructions, particularly chapters „Important Safety Information“ and „General Operation“,
- and has been familiarized with mode of action and handling the tail lift.

## Safety Instructions in these Instructions

Safety instructions have been included before any instruction for actions where the risk of personal injuries or material damage exists.

Safety instructions are structured as follows:

### SIGNAL WORD



#### Description of type and source of hazard

Description of consequences if instructions are not observed

▶ Description of actions to eliminate the hazard

The described actions to eliminate the hazard must be absolutely complied with!

The signal word designates the severity of the hazard:

Signal word	Usage
<b>DANGER!</b>	<b>Indicates a direct</b> serious hazard that will result in severe injuries or even death, if the hazard is not avoided.
<b>WARNING!</b>	<b>Indicates a potential hazard that may result in severe injuries or even death, if the hazard is not avoided.</b>
<b>CAUTION!</b>	<b>Indicates a potentially hazardous situation that may result in medium or light injuries or damage to property if the hazard is not avoided.</b>

## Observe the Following

### General Notes



- Always have these instructions readily available in the vehicle.
- Constructional changes may only be performed by the contractor repair shop of **PALFINGER Tail Lifts**. You will find the address of your local contractor repair shop and other contact information in the list of repair shops.
- For maintenance, use only original **PALFINGER Tail Lifts** spare parts.
- Observe all applicable accident prevention regulations.

### When Switching On



- Before switching on the tail lift, check whether all safety and warning devices are in place and function properly.
  - Warning flags
  - Warning lights
  - Supporting straps
  - Roll stops

### During Operation



- Make sure that the tail lift is unlocked before taking it into operation.
- Provide sufficient illumination of the loading area.
- Never transport persons on the tail lift.
- Always load the tail lift in such a way that the weight is evenly distributed.
- Secure the load so that it cannot fall off the tail lift. Rolling containers without brakes may only be transported on the tail lift if you secure them with roll stops (roll-off protection) against rolling away.
- Keep the maneuvering area around the vehicle free.

### Prior to Maintenance



- Switch off the battery main switch or remove the grounding strap.
- Secure or relieve the springs before replacement.
- If hydraulic oil emerges, do not put your hands into the oil stream.
- When executing any maintenance work under the platform, secure the moving part against moving down.

### At Disposal



- Dispose of oils and filters according to the regulations in your country.

## PALFINGER Tail Lifts– The Tail Lift

Congratulations to the purchase of your new tail lift made by **PALFINGER Tail Lifts!**

With more than 50 years of experience in the field of hydraulic tail lifts, **PALFINGER Tail Lifts GmbH** is among the leading manufacturers of these highly helpful load systems.

You will encounter the tail lifts of the **PALFINGER Tail Lifts** brand and also former brands such as Hubfix, Interlift, and Hayons Inter in more than 40 countries throughout the world. More than 100,000 tail lifts manufactured in the factory near Bremen can be found on all five continents.

A unique service network with more than 2,500 service stations in Europe alone guarantees optimum logistics without borders. Your new **PALFINGER Tail Lifts** tail lift is features innovative and reliable technology. It was manufactured by our employees with great care. These are the best prerequisites for a long and problem-free service-life.

To familiarize yourself with the operation of the new tail lift, we ask you to read the following operating instructions carefully. In these instructions you also find the necessary safety instructions for the operation of the tail lift.

In case you have any questions concerning your tail lift, the **PALFINGER Tail Lifts** service team is readily available for you.

## Scope of Delivery

- Tail lift
- Adhesive label – ETMA information
- Large identification plate (for the platform)
- Small identification plate (for the lifting device)
- Underrun bumper shield (UBS)
- Load diagram
- Operating Instructions
- Test data booklet
- Starter kit, consists of:
  - Underrun bumper certificate
  - Assembly instructions
  - Brief operating instructions
  - Large inspection organization (TÜV) plate
  - Small inspection organization (TÜV) plate

# How to Find Your Tail Lift Model

Each tail lift model has been assigned a letter (**A** to **V**) in these operating instructions. You will find the letter at the beginning of each chapter that contains information concerning your tail lift model. The following overview indicates which letter is valid for your model.

## Standard Tail Lifts

### A

#### Lateral Operating Pane

MBB C 1000 S – C 3000 S

MBB C 1000 LD – C 2500 L

MBB C 1500 SZ – C 2500 SZ

MBB C 1500 SK – C 2500 SK

MBB C 750 SPLD SPRD –  
C 1000 SPL SPR

MBB C 750 LD – C 1000 L

MBB C 1000 ML – C 1500 ML

MBB C 1000 ML PRO –  
C 1500 ML PRO

MBB C 750 S

MBB C 750 LX

MBB C 750 SX

MBB C 500 LD – C 750 L

MBB C 750 SPL SPR

MBB C 1500 LX – C 2000 LX

MBB C 1000 SB – C 1500 LB

### B

#### One-Cylinder Model

MBB C 500 LG

### C

#### minifix

MBB C 350 VAN – C 500 VAN

### E

#### Electrical Cylinders

MBB C 1000 E

## Retractable Tail Lifts

### **F** Platform Single-Folded

MBB R 750 L – R 2500 S  
 MBB R 1500 L  
 MBB R 1500 L FLAT  
 MBB R 1500 SK – R 2000 LK  
 MBB R 1500 S TRAIL –  
 R 2000 L TRAIL  
 MBB R 1500 S TRUCK –  
 R 2000 L TRUCK  
 MBB R 1000 S TRUCK-LGD –  
 R 2000 L TRUCK-LGD  
 MBB R 1500 S TRAIL-LGD –  
 R 2500 L TRAIL-LGD

### **G** Platform Double-Folded

MBB R 1500 SH – R 2000 LH  
 MBB R 750 SM – R 2000 LM

## Foldable Tail Lifts

### **K** Four-Cylinder Model

MBB F 1000 SH – F 2000 LH  
 MBB F 1000 SX – F 1500 LX

### **L** Two-Cylinder Model

MBB F 1000 LD – F 1500 LU  
 MBB F 1000 L – F 1500 L

### **M** One-Cylinder Model

MBB F 500 L – F 600 L

## Column Lifts

### **V** Standard Column Lift

MBB V 4000 S

## Model Overviews

### A Standard Tail Lifts

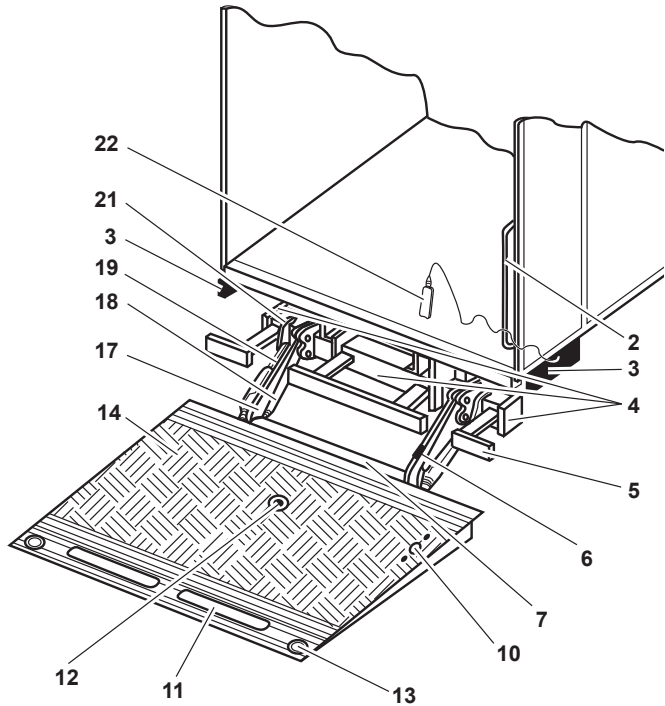

- |    |   |    |   |
|----|---|----|---|
| 2  | Supporting strap on body (not in scope of delivery) | 11 | Roll stop (roll-off protection, optional) |
| 3  | Lateral operating panel                             | 12 | Payload center of gravity                 |
| 4  | Hydraulic unit                                      | 13 | Warning lights (optional)                 |
| 5  | Underrun bumper                                     | 14 | Platform                                  |
| 6  | Lift arms switch b13, tilt sensor b15               | 17 | Torsion frame                             |
| 7  | Lift arms switch b16, tilt sensor b15               | 18 | Lift cylinder                             |
| 10 | Foot control  | 19 | Tilt cylinder                             |
|    |   | 21 | Support tube                              |
|    |   | 22 | Hand cable control                        |

## **B Standard Tail Lifts**

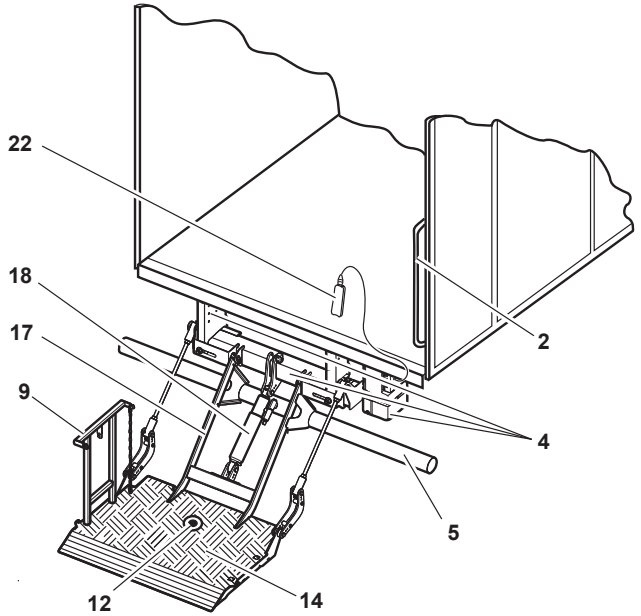

- |   |                                     |
|---|-------------------------------------|
| <b>2</b> Supporting strap on body<br>(not in scope of delivery) | <b>12</b> Payload center of gravity |
| <b>4</b> Hydraulic unit   | <b>14</b> Platform                  |
| <b>5</b> Underrun bumper  | <b>17</b> Torsion frame             |
| <b>9</b> Railing  | <b>18</b> Lift cylinder             |
|   | <b>22</b> Hand cable control        |

## C Standard Tail Lifts

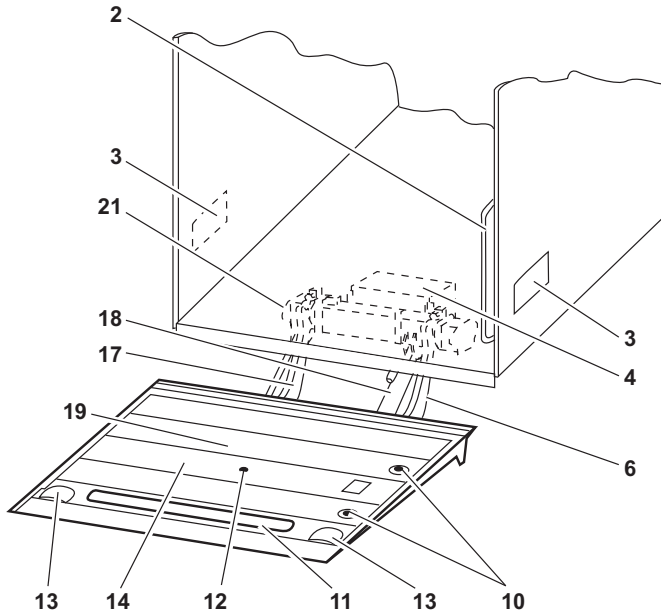

- |   |  |
|---|--|
| <b>2</b> Supporting strap on body<br>(not in scope of delivery) | <b>13</b> Warning lights<br>(optional)           |
| <b>3</b> Lateral operating panel                                | <b>14</b> Platform                               |
| <b>4</b> Hydraulic unit   | <b>17</b> Torsion frame                          |
| <b>6</b> Lift arms switch b13                                   | <b>18</b> Lift cylinder                          |
| <b>10</b> Foot control  | <b>19</b> Tilt cylinder (covered by<br>platform) |
| <b>11</b> Roll stop (roll-off protection,<br>optional)          | <b>21</b> Support tube                           |
| <b>12</b> Payload center of gravity                             |  |

## **E Standard Tail Lifts with Electrical Cylinders**

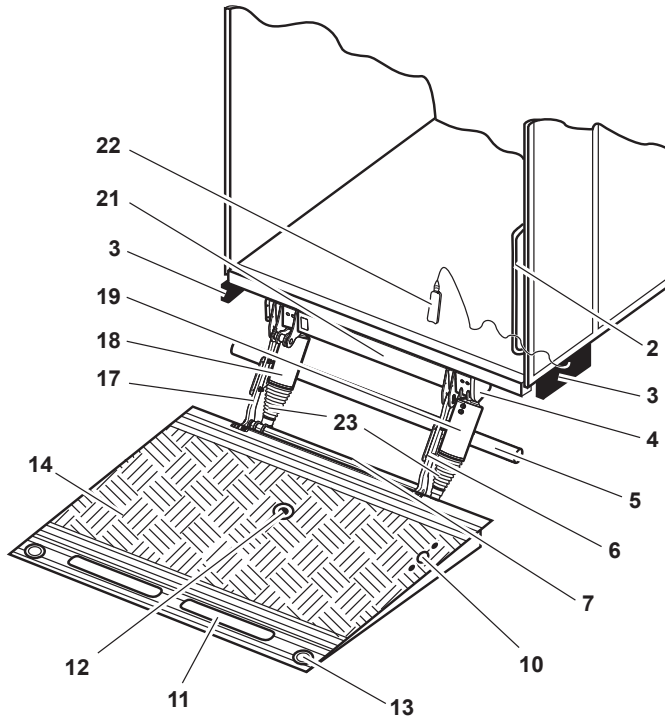

- |  |                                     |
|--|-------------------------------------|
| <b>2</b> Supporting strap on body (not in scope of delivery) | <b>12</b> Payload center of gravity |
| <b>3</b> Lateral operating panel                             | <b>13</b> Warning lights (optional) |
| <b>4</b> Power unit  | <b>14</b> Platform                  |
| <b>5</b> Underrun bumper                                     | <b>17</b> Torsion frame             |
| <b>6</b> Tilt sensor b15                                     | <b>18</b> Lift cylinder             |
| <b>7</b> Tilt sensor b15                                     | <b>19</b> Tilt cylinder             |
| <b>10</b> Foot control                                       | <b>21</b> Support tube              |
| <b>11</b> Roll stop (roll-off protection, optional)          | <b>22</b> Hand cable control        |
|  | <b>23</b> Bellows                   |

## FG Retractable Tail Lifts

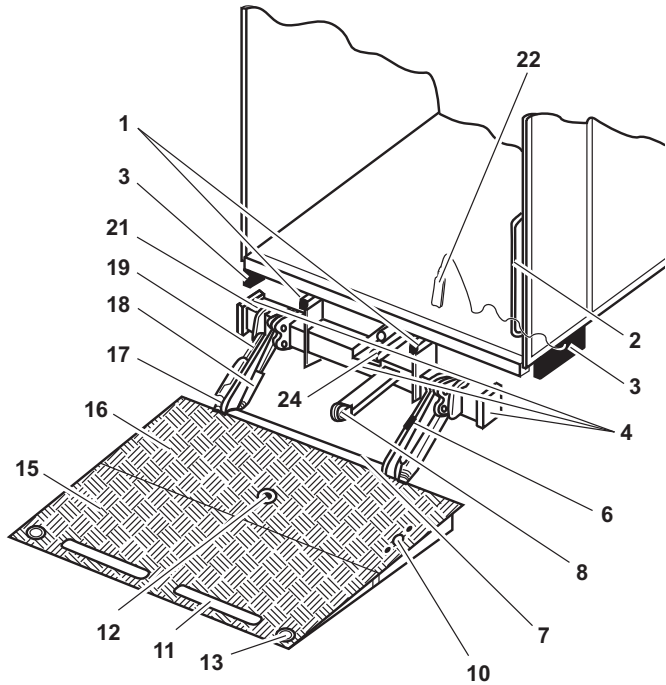

- |  |                                       |
|--|---------------------------------------|
| <b>1</b> Guide rails   | <b>12</b> Payload center of gravity   |
| <b>2</b> Supporting strap on body (not in scope of delivery) | <b>13</b> Warning lights (optional)   |
| <b>3</b> Lateral operating panel                             | <b>15</b> Folding part of platform    |
| <b>4</b> Hydraulic unit                                      | <b>16</b> Stationary part of platform |
| <b>6</b> Lift arms switch b13, tilt sensor b15               | <b>17</b> Torsion frame               |
| <b>7</b> Lift arms switch b16, tilt sensor b15               | <b>18</b> Lift cylinder               |
| <b>8</b> Guide pulley  | <b>19</b> Tilt cylinder               |
| <b>10</b> Foot control (optional)                            | <b>21</b> Support tube                |
| <b>11</b> Roll stop (roll-off protection, optional)          | <b>22</b> Hand cable control          |
|  | <b>24</b> Guide cylinder              |

## Retraction Equipment

F

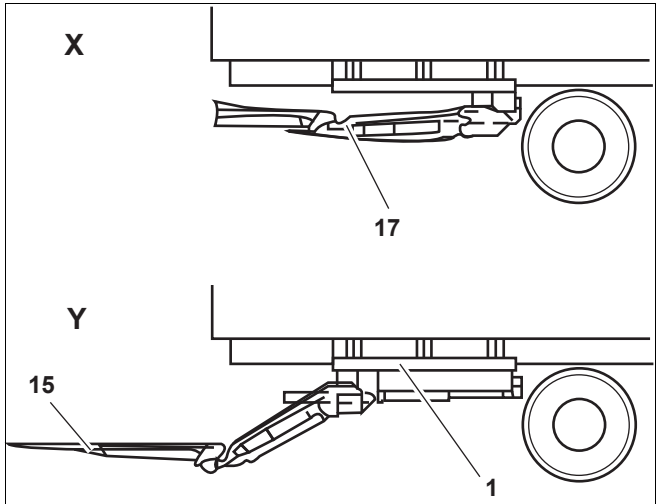

G

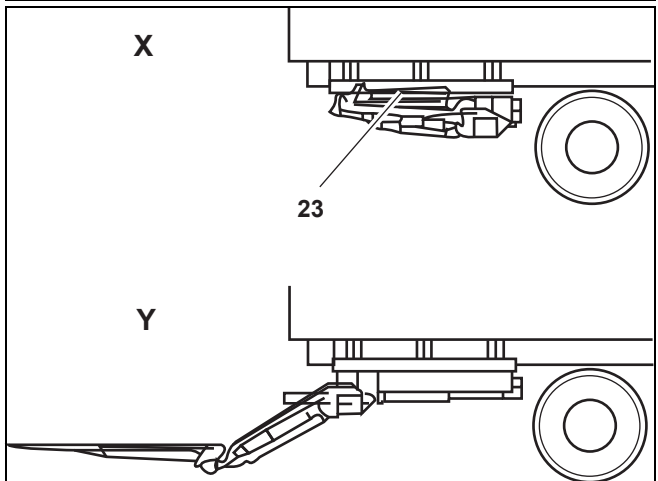

- 1 Guide rails
- 15 Folding part of platform
- 17 Torsion frame
- 23 Platform package

- X Transport position
- Y Operating position

## K L M Foldable Tail Lifts

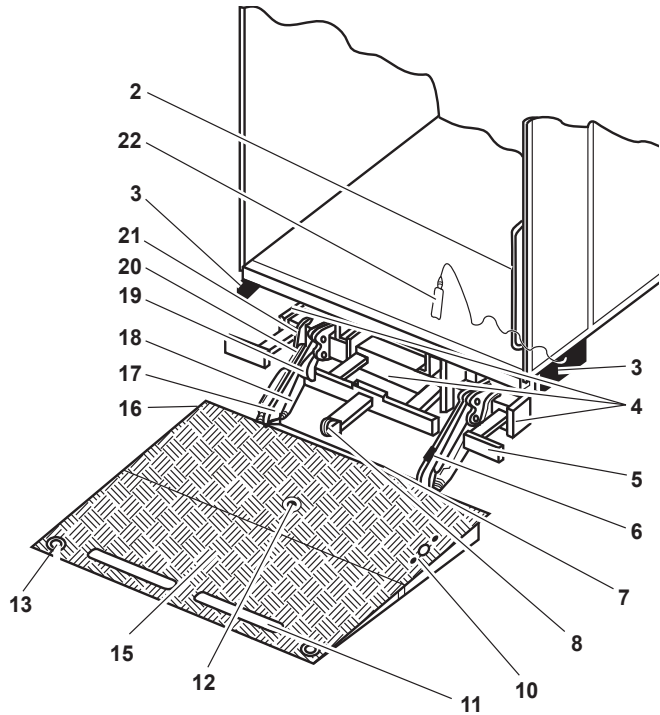

- |    |   |    |                             |
|----|---|----|-----------------------------|
| 2  | Supporting strap on body (not in scope of delivery) | 12 | Payload center of gravity   |
| 3  | Lateral operating panel                             | 13 | Warning lights (optional)   |
| 4  | Hydraulic unit                                      | 15 | Folding part of platform    |
| 5  | Underrun bumper                                     | 16 | Stationary part of platform |
| 6  | Lift arms switch b13, tilt sensor b15               | 17 | Torsion frame               |
| 7  | Lift arms switch b16, tilt sensor b15               | 18 | Lift cylinder               |
| 8  | Guide pulley  | 19 | Tilt cylinder               |
| 10 | Foot control (optional)                             | 20 | Roller at underrun bumper   |
| 11 | Roll stop (roll-off protection, optional)           | 21 | Support tube                |
|    |   | 22 | Hand cable control          |

## V Column Lifts

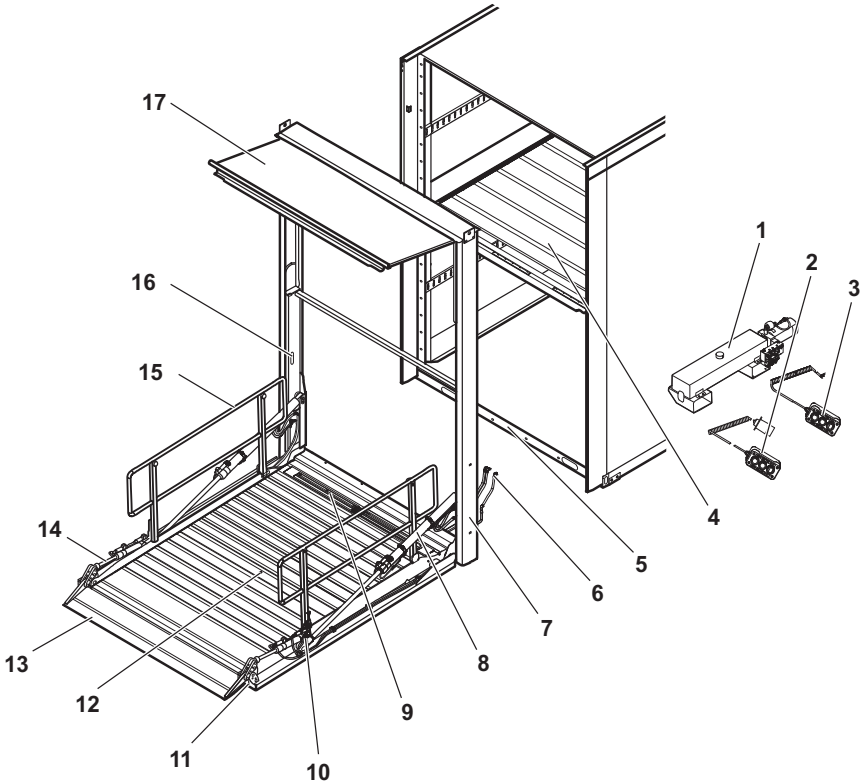

- |   |   |    |   |
|---|---|----|---|
| 1 | Hydraulic unit with oil tank                  | 10 | Tilt sensor b15 (factory-set, do not change position) |
| 2 | Hand cable control 1                          | 11 | Warning light   |
| 3 | Hand cable control 2                          | 12 | Payload center of gravity                             |
| 4 | Vehicle deck 2                                | 13 | Link bridge (roll stop, towards external side)        |
| 5 | Vehicle deck 1                                | 14 | Tilt cylinder   |
| 6 | Hydraulic hoses (connected to hydraulic unit) | 15 | Safety railing  |
| 7 | Guide frame                                   | 16 | Slide   |
| 8 | Closing cylinder                              | 17 | Top flap  |
| 9 | Roll-stop, towards vehicle rear               |    |   |

## Presetting the Tail Lift

This chapter provides principle settings to enable the comfortable and safe use of the tail lift.

**A C F**

### Setting the Ground Adjustment Timing

Only for E-Type equipment with lift arms switch b13 the workshop can determine the time the platform initiates the tilt process (ground adjustment) after making contact with the ground.

To adjust the timing for the ground adjustment:

- ▶ Loosen the fastening screw at lift arms switch b13 (6).
- ▶ To set an „earlier“ ground adjustment, turn lift arms switch b13 (6) a few millimeters clockwise.  
To set a „later“ ground adjustment, turn lift arms switch b13 (6) a few millimeters counterclockwise.
- ▶ Retighten the fastening screw at lift arms switch b13 (6).
- ▶ Check whether the platform initiates the tilt process at the time desired.
- ▶ Check whether the spring washer is mounted between lift arms switch and screw and fold back the locking plate.

*The time the platform is supposed to tilt has been preset now. The platform tilts earlier or later.*

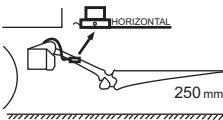
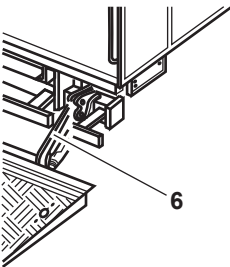

**A E F G K**

### Presetting the Platform Tilt

After the platform was lifted from the ground, it reverts to the preset position. You can adjust the tilt of the platform slightly higher or lower.

- ▶ Adjust the desired upper position using the “Open/Close” pushbuttons of the operating panel (see chapter “Operating Elements” from p. 38). This is only possible with the tilt sensor b15 on the platform.

## A Adjusting the pressure switch of the hydraulic stabilizer feet

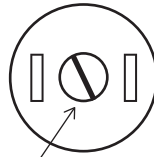

Turn set screw  
(adjustment range 20 to 50 bars)  
- clockwise to  
increase pressure  
- counterclockwise to  
reduce pressure

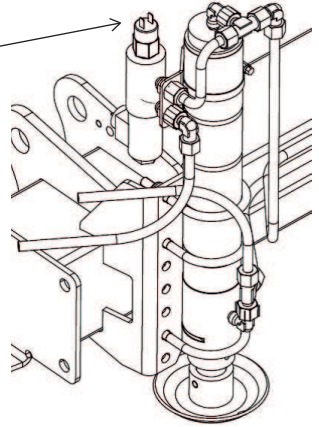

If the hydraulic stabilizer feet should lift the vehicle excessively or should not reach the ground, the pressure switch of the stabilizer can be adjusted.

For this purpose, turn the set screw on the pressure switch.

In order to reduce the contact pressure of the stabilizer feet, turn the set screw counterclockwise by one turn.

In order to increase the contact pressure of the stabilizer feet, turn the set screw clockwise by one turn.

After the adjustment, verify the contact pressure by lowering the stabilizer feet. If the stabilizer feet are not yet switched off as required, repeat the setting procedure.

## General Operation

This chapter provides basic information that you must observe during operation. This information applies to all tail lift models.

- ▶ Read the entire chapter carefully and pay special attention to the following safety instructions.

### CAUTION!



#### **Hazard of battery discharge!**

When the symbol shown on the left is depicted on the operating element of your tail lift, the tail lift is equipped with a battery monitoring system (BÜW).

When the battery capacity falls below the limit value, a buzzer is sounded and the tail lift is automatically switched off, to conserve battery power. The battery power is already at a low level that only one more engine start is possible. IF you continue to use the tail lift, you will not be able to start the vehicle!

- ▶ Start the vehicle engine immediately after hearing the buzzer, to recharge the battery!

**Note:** For more information on the recommended battery capacity refer to the corresponding table on p. 156.

## Switching on the Tail Lift

### CAUTION!



#### Risk of injury or material damage due to insufficient safety measures!

Personnel can be injured and material damage can occur at your vehicle, the tail lift, or other vehicles if you do not observe the following:

- ▶ Prior to starting work, be sure that all safety and warning devices are present and operational.
- ▶ Only stop in places where the traffic regulations permit a stop.
- ▶ Secure the vehicle against rolling away, for example by using the parking brake, engaging a gear, or wheel chocks.
- ▶ Secure the traffic area with warning flags and warning lights before loading or unloading the vehicle. Pay special attention to secure the operating elements of the tail lift that stick out into the moving traffic.

Depending on the model there are four ways to switch on the tail lift:

- Switch in driver's cab
- Key control at lateral operating element
- Key code at lateral operating element
- Battery main switch

To switch on the tail lift using the **switch** in the driver's cab:

- ▶ Set the switch in the driver's cab to "ON".

*The switch marking is no longer visible.*

*The operational readiness of the tail lift is shown by an optical signal in the driver's cab.*

*If the vehicle is equipped with a starter interlock, the vehicle cannot be started.*

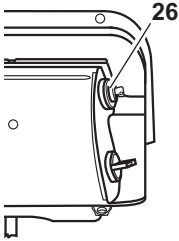

To switch on the tail lift using the **key control (26)** at the lateral operating element:

- ▶ Insert the key into the keyhole of the key control and turn it clockwise.

*The operational readiness of the tail lift is shown by an optical signal in the driver's cab.*

To switch on the tail lift using the **key code** at the lateral operating element:

- ▶ Enter the key code using the Lift and Close pushbuttons (see Chapter "Programming a Key Code" from p. 116").

*The operational readiness of the tail lift is shown by an optical signal in the driver's cab.*

To switch on the tail lift using the **battery main switch**:

- ▶ Turn the battery main switch clockwise until the cam is engaged.

*The operational readiness of the tail lift is shown by an optical signal in the driver's cab.*

## Extending the Stabilizer Feet at Your Vehicle

### CAUTION!



#### Damage to the vehicle!

The vehicle chassis frame can be damaged by insufficient carrying capacity of the ground or by incorrectly adjusted hydraulic stabilizer feet.

- ▶ Make sure that the carrying capacity of the ground is appropriate for the stabilizer feet!
- ▶ Never lift up the vehicle by means of the hydraulic stabilizer feet!
- ▶ Readjust the stabilizer feet several times while loading the vehicle.

### CAUTION!



#### Risk of injury or material damage for vehicles with air suspension

When you do not block the air suspension of your vehicle, the load is completely taken off the axles and the weight is transferred to the stabilizer feet. This can result in personal injuries and your tail lift, your vehicle, or the load can be damaged.

- ▶ Set the air suspension control lever of your vehicle to position "Block"!

#### Vehicles with Mechanical Stabilizer Feet

Mechanical stabilizer feet prevent chassis damage. When loading the vehicle, the stabilizer feet skid through.

To extend the mechanical stabilizer feet:

- ▶ Loosen the clamping device.
- ▶ Lower the stabilizer feet until they touch the ground.
- ▶ Hand-tighten the clamping device.

#### Vehicle with Hydraulic Stabilizer Feet

- ▶ To extend the hydraulic stabilizer feet, see "Operation Using Two-hand Control and Hydraulic Stabilizer Feet" from p. 44.

## Retracting the Stabilizer Feet at Your Vehicle

### Retracting Mechanical Stabilizer Feet

- ▶ Loosen the clamping device.
- ▶ Push the stabilizer feet back into the transport position.
- ▶ Hand-tighten the clamping device.

### Retracting Hydraulic Stabilizer Feet

#### CAUTION!



#### Risk of chassis damage!

In case of vehicles with air suspension, the entire weight can be shifted to the stabilizer feet.

- ▶ Before retracting the stabilizer feet, lift the vehicle by means of the air suspension in such a way that the stabilizer feet are relieved.
- ▶ To retract the hydraulic stabilizer feet, see “Operation Using Two-hand Control and Hydraulic Stabilizer Feet” from p. 44.

## Putting up or laying down the safety railing at the platform

Depending on the model, the platform of your tail lift is protected by a safety railing. There are two possible basic types of safety railings:

- a P-shaped safety railing
- an A-shaped safety railing

In order to put up or lay down the safety railings at the platform, proceed as described below:

### Putting up P-shaped safety railings

- ▶ Rotate the respective safety railing by 90° upwards, until it locks into place.

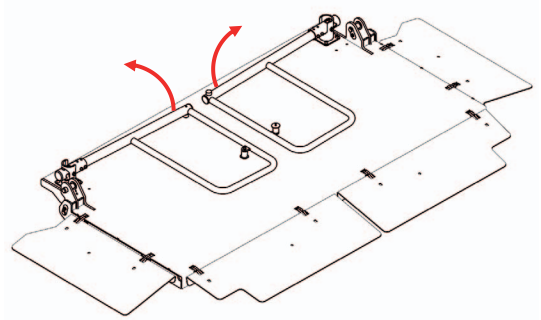

### Laying down P-shaped safety railings

- ▶ To unlock pull up the respective safety railing (1).
- ▶ Rotate the respective safety railing inwards (2), until the magnetic resilient pad touches down onto the platform.

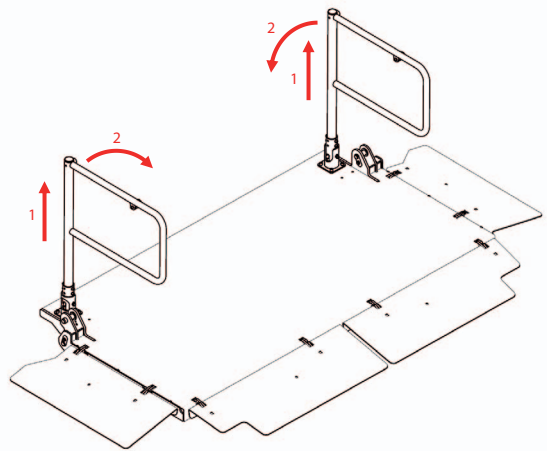

### Putting up A-shaped safety railing

- ▶ Pull the respective safety railing briefly towards the center of the platform (1).
- ▶ Rotate the respective safety railing by 90° upwards (2) and lower it until it locks into place.

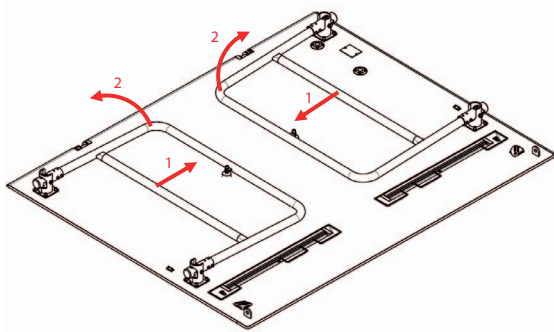

### Laying down A-shaped safety railing

- ▶ Pull up the respective safety railing (1).
- ▶ Then rotate the respective safety railing inwards (2), until the magnetic resilient pad touches down onto the platform.

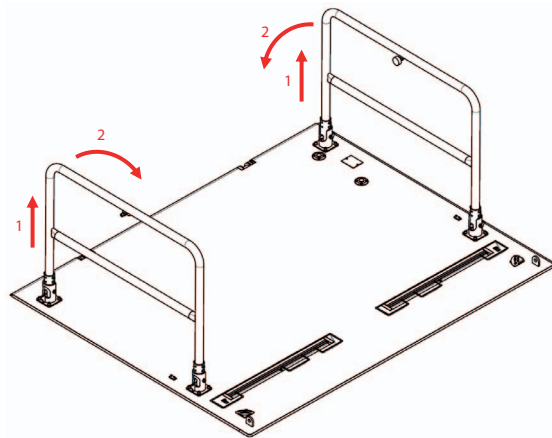

## Moving the Platform

### CAUTION!



#### Risk of injury and material damage when moving the platform!

Personnel can be injured when moving the platform. Vehicles and other object in the maneuvering area can be damaged. Load items can fall down and be damaged or injure other persons.

- ▶ Make sure that sufficient space is available behind the vehicle for the tail lift.
- ▶ Keep other persons away from the maneuvering area while you move the platform.
- ▶ Watch the payload, the maneuvering area, and the squeeze area to the vehicle while you move the platform.
- ▶ Observe that the operating element are only actuated to move the platform.
- ▶ Adjust the platform tilt only in no-load condition.

### CAUTION!



#### Risk of injury because of insufficient holding or too little space on the platform!

Persons can fall off the platform and suffer from injuries.

- ▶ When loading the platform, leave enough free space for the operator (minimum 50 x 60 cm).
- ▶ Only one person – the operator – is allowed to travel on the platform at any time.
- ▶ Never hold the payload, always hold tight to the supporting strap!
- ▶ Watch the payload and the maneuvering area while moving the platform.

How to move the platform depends on the model and the associated lateral operating element. For a detailed description refer to chapter “Operating Elements” from p. 38.

## Explanation of Terms

Actions for the platform:

- **Open**



The platform opens and moves from the vertical transport position to the desired operating position. This position is stored and reverted to when lifting the platform after the ground adjustment.

- **Close**



The platform closes and moves from the horizontal operating position to the vertical transport position.

- **Extend**

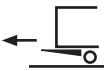

The platform extends from under the vehicle.

- **Retract**

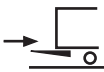

The platform retract under the vehicle.

- **Fold out**



The platform folds out from the transport position to the operating position.

- **Fold in**



The platform folds in from the operating position to the transport position.

- **Lower**



The platform moves in horizontal position downwards.

- **Lift**



The platform moves in horizontal position upwards.

• **Ground adjustment**



After bringing down the platform it tilts from the operating position to adjust to the ground level.

The foldable models **M** tilt gradually during bringing down the platform.

• **Setting the Platform to its Horizontal Position**



Before the platform is raised from the ground it tilts back into the horizontal operating position that was stored during opening.

The foldable models **M** tilt gradually during lifting to the horizontal operating position.

• **Set the platform tilt**



The platform can move to the desired operating position with a higher or lower tilt angle.

**Opening/Folding out/Extending the Platform and Setting the Platform Tilt**

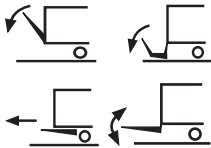

- ▶ Loosen the platform interlock (if present).
- ▶ Open, fold out or extend the tail lift depending on the model by means of the lateral operating element, the foot control, or the hand cable control, as described in chapter “Operating Elements” from p. 38 in this manual.
- ▶ Depending on the model, turn the rotary switch to open or close the platform, as described in chapter “Operating Elements” from p. 38 in this manual, until the unladen platform reaches the desired tilt angle.

**Bringing Down the Platform**



While the platform is brought down it remains in horizontal position. After the platform has touched the ground it tilts until the platform edge is flush with the ground.

- ▶ Lower the platform depending on the model by means of the lateral operating element, the foot control, or the hand cable control, as described in chapter “Operating Elements” from p. 38 in this manual.

*The platform is slowly brought down and automatically adjusts to the ground.*

## Lifting the Platform



Before the platform is lifted it tilts to the horizontal position. While the platform is lifted it remains in horizontal position.

- ▶ Lift the platform depending on the model by means of the lateral operating element, the foot control, or the hand cable control, as described in chapter "Operating Elements" from p. 38 in this manual.

## Closing/Folding In/Retracting the Platform

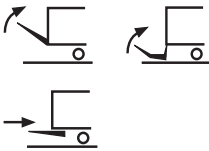

- ▶ Close, fold in or retract the platform depending on the model by means of the lateral operating element, the foot control, or the hand cable control, as described in chapter "Operating Elements" from p. 38 of this manual.
- ▶ Close the platform interlock (if present).

## Loading or Unloading the Platform

### CAUTION!



#### Damage to the tail lift by incorrect loading!

The tail lift can be damaged if the platform load is too high or unbalanced.

- ▶ Do not exceed the maximum load weight specified in chapter "Technical Data" from p. 156 of this manual when loading the platform. Take the weight of the operator standing on the platform into account. The load diagram is also shown at the lateral operating element.
- ▶ Center the load on the platform. The payload center of gravity should be as close to the vehicle as possible. If you load the platform on one side only, the payload weight may be max. 50% of the permitted payload.
- ▶ Rolling containers without brakes may only be loaded if the tail lift is equipped with a roll-off protection (roll stops or grooves). Rolling containers without brakes must always be secured by this roll-off protection.

### CAUTION!



#### Risk of injury!

Persons can fall off the platform and suffer from injuries.

- ▶ When loading the platform, leave enough free space for the operator (minimum 50 x 60 cm).

## Loading or Unloading the Platform on the Ground

- ▶ Roll or lift the payload onto the platform.
- ▶ Secure any rolling containers on the tail lift by installed brake devices or roll-off protections.

## Loading or Unloading the Platform at a Ramp

### CAUTION!



#### Risk of falling when loading at a ramp!

Person can trip and fall down if there is an edge between ramp and platform during loading or unloading.

- ▶ When the vehicle is unloaded and is lifted up by the spring action, lower the platform manually.

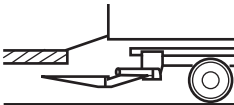

min. 150 mm

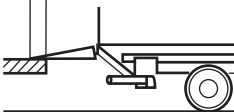

#### Note:

You can load your vehicle at a ramp in two possible ways:

1. You can use a separate dock plate. Make sure that sufficient space for tail lift exists under the ramp (see figure on the left)!
2. You can use the tail lift itself as dock plate at a ramp. Make sure that the platform edge overlaps the ramp at least 150 mm (see figure on the left).

The maximum permissible load must not be exceeded.

The tail lifts are equipped with a float mode. The float mode is a safety feature. When the vehicle lowers itself during loading, the float mode causes the platform to automatically yield and reposition itself. This does not apply to column lifts.

The float mode does not function during unloading. You must manually lower the platform. Thus you prevent a gap between platform and ramp where you could trip.

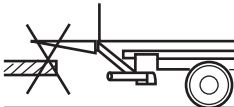
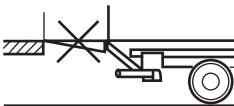

## Switching off the Tail Lift

The tail lift may only be switched off when the platform is closed and/or folded in.

### CAUTION!



#### Risk of injury or material damage due to unlocked tail lift!

Persons can be injured or vehicles and objects in public road traffic can be damaged if the tail lift folds out accidentally during driving and sticks out into the moving traffic.

- ▶ Before driving, lock the tail lift after folding in.
- ▶ Make sure that the warning lights **(25)** in the driver's cab are not lit.

Depending on the model, there are various different ways to switch off the tail lift:

- Switch in driver's cab
- Key control at lateral operating element
- Key code at lateral operating element
- Battery main switch
- Driver's cab control unit with camera system

To switch off the tail lift using the **switch** in the driver's cab:

- ▶ Set the switch at the control box in the driver's cab to "OFF".

*The visual signal indicating the operational readiness of the tail lift extinguishes. The tail lift is switched off.*

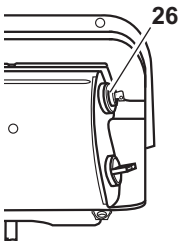

To switch off the tail lift using the **key control (26)** at the lateral operating element:

- ▶ Insert the key into the keyhole of the key control and turn it counterclockwise.
- ▶ Remove the key.

*The visual signal indicating the operational readiness of the tail lift extinguishes. The tail lift is switched off.*

To switch off the tail lift using the **key code** at the lateral operating element:

- ▶ Enter the key code using the Lift and Close pushbuttons (see Chapter “Programming a Key Code” from p. 116).

*The visual signal indicating the operational readiness of the tail lift extinguishes. The tail lift is switched off.*

To switch off the tail lift using the **battery main switch**:

- ▶ Turn the battery main switch counterclockwise until the cam is engaged.

*The visual signal indicating the operational readiness of the tail lift extinguishes. The tail lift is switched off.*

## Driver's cab control unit

- Note:** In case there is a driver's cab control unit with camera system, please observe the complement to the operating instructions which is added to the driver's cab control unit as a separate document.

# Operating Elements

This chapter describes the operating elements of the different tail lift models. To identify your model, refer to “How to Find Your Tail Lift Model”, p. 12.

## CAUTION!



### Risk of accidents and injury!

If the safety and warning devices of the tail lift are damaged or missing, personal injuries or material damage can occur.

- ▶ Ensure that all safety and warning devices are present and operational.

You can operate the tail lift in several possible ways:

1. using the lateral operating element (depending on the model, see p. 38 to p. 116),
2. using the joystick (see p. 52)
3. using the two manual cable switches (for column lift, see p. 92),
4. using the foot control (optional, see p. 98) or
5. using the hand cable control (optional, see p. 100) or
6. using the radio remote control unit (optional, see p. 108) or
7. using the special operating elements (optional, see p. 110).

## Lateral Operating Element

Depending on your tail lift model you find information about the operation of the lateral operating element on:

<b>A E</b>	p. 39 to p. 50
<b>A</b>	p. 52
<b>B</b>	p. 84 to p. 90
<b>C</b>	p. 54
<b>F</b>	p. 56 to p. 62
<b>G</b>	p. 68 to p. 76
<b>K</b>	p. 80 to p. 82
<b>L</b>	p. 84 to p. 86
<b>M</b>	p. 84 to p. 90

## A E Operation Using Two-hand Control

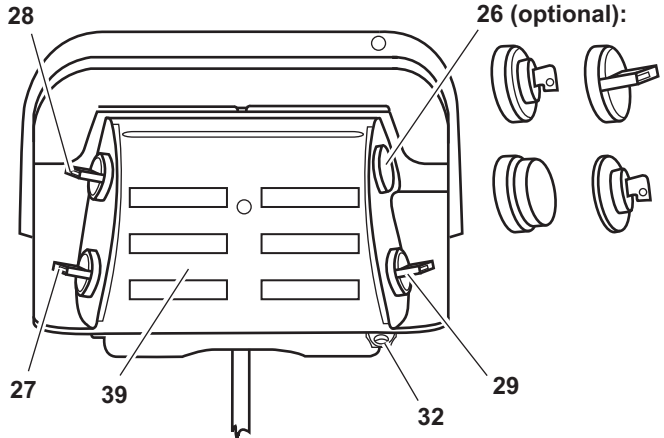

- 26 Optional: key control, rotary switch, emergency-off pushbutton, E30 key
- 27 Rotary switch: lift/lower
- 28 Rotary switch: open/close
- 29 Rotary switch: additional pushbutton
- 32 Locking lug
- 39 Operating panel

### DANGER!



#### Risk of accidents and injury!

If the instructions in chapter “General Operation” are not observed during operation of the tail lift, personal injuries and material damage can occur.

- Before operating the tail lift, read chapter “General Operation” from p. 24.

### Opening the Platform



- ▶ Loosen the platform interlock (if present).
- ▶ Turn the rotary switches **(28)** and **(29)** simultaneously downward and hold them down until the platform has reached the horizontal operating position.

*If an optional load safety device is present, the platform is lowered a small amount and then unfolds to the horizontal operating position.*

### Lowering the Platform



- ▶ Turn the rotary switches **(27)** and **(29)** simultaneously downward and hold them in this position until the platform has made contact with the ground.

*After the platform has touched the ground it tilts and adjusts to the ground.*

### Lifting the Platform



- ▶ Turn the rotary switches **(27)** and **(29)** simultaneously upward and hold them in this position until the platform has reached the vehicle loading floor height.

*The platform tilts to the horizontal or preset position before it is lifted.*

### Closing the Platform



- ▶ Turn the rotary switches **(28)** and **(29)** simultaneously upward and hold them in this position until the platform is closed.

*If an optional load safety device is present, the platform closes approximately to 80° and is lowered a small amount. Subsequently it moves to the vertical transport position and is lifted into the load safety device.*

- ▶ Close the platform interlock (if present).



## A Operation Using Two-hand Control without Automatic Ground Adjustment

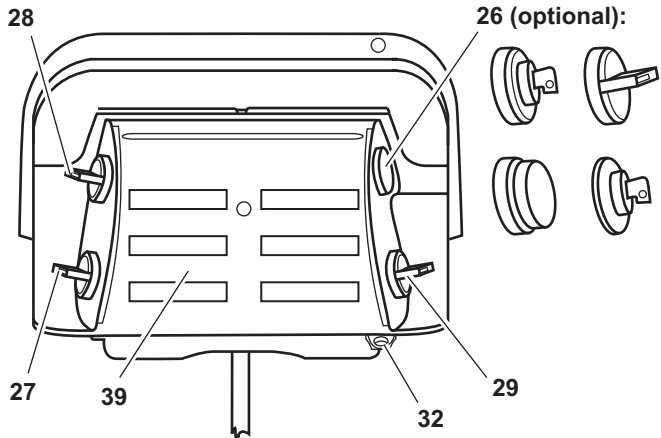

- 26** Optional: key control, rotary switch, emergency-off pushbutton, E30 key
- 27** Rotary switch: lift/lower
- 28** Rotary switch: open/close
- 29** Rotary switch: additional pushbutton
- 32** Locking lug
- 39** Operating panel

### DANGER!



#### Risk of accidents and injury!

If the instructions in chapter “General Operation” are not observed during operation of the tail lift, personal injuries and material damage can occur.

- ▶ Before operating the tail lift, read chapter “General Operation” from p. 24.

### Opening the Platform



- ▶ Loosen the platform interlock (if present).
- ▶ Turn the rotary switches (28) and (29) simultaneously downward and hold them down until the platform has reached the horizontal operating position.

### Lowering the Platform



- ▶ Turn the rotary switches (27) and (29) simultaneously downward and hold them in this position until the platform has reached the ground.

### Ground Adjustment



After the platform has touched the ground:

- ▶ Turn the rotary switches (28) and (29) simultaneously downward.

*The platform tilts and adjusts flush to the ground.*

### Setting the Platform to its Horizontal Position



- ▶ Turn the rotary switches (28) and (29) simultaneously upward and hold them in this position until the platform has reached the horizontal position.

### Lifting the Platform



- ▶ Turn the rotary switches (27) and (29) simultaneously upward and hold them in this position until the platform has reached the vehicle loading floor height.

### Closing the Platform



- ▶ Turn the rotary switches (28) and (29) simultaneously upward and hold them in this position until the platform is closed.

*The platform moves to the vertical transport position.*

- ▶ Close the platform interlock (if present).

## A Operation Using Two-hand Control and Hydraulic Stabilizer Feet

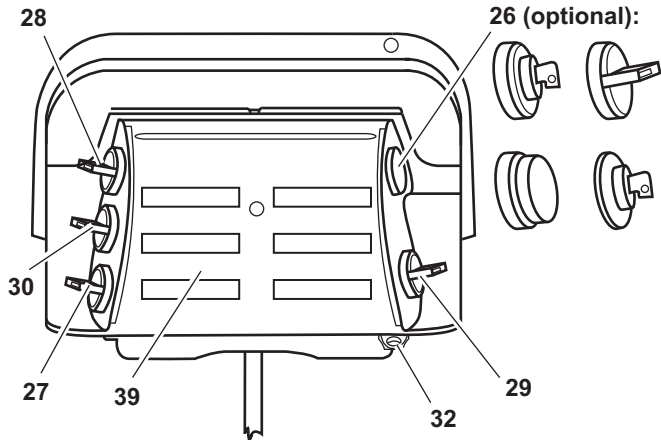

- 26** Optional: key control, rotary switch, emergency-off pushbutton, E30 key
- 27** Rotary switch: lift/lower
- 28** Rotary switch: open/close
- 29** Rotary switch: additional pushbutton
- 30** Rotary switch: retract and extend
- 32** Locking lug
- 39** Operating panel

### DANGER!



#### Risk of accidents and injury!

If the instructions in chapter “General Operation” are not observed during operation of the tail lift, personal injuries and material damage can occur.

- ▶ Before operating the tail lift, read chapter “General Operation” from p. 24.

#### Extending the Hydraulic Stabilizer Feet

- ▶ Turn the rotary switch (**30**) downward until the stabilizer feet are extended almost to the ground.

### Opening the Platform



- ▶ Loosen the platform interlock (if present).
- ▶ Turn the rotary switches (27) and (29) simultaneously downward and hold them down until the platform has reached the horizontal operating position.

*If an optional load safety device is present, the platform is lowered and then unfolds to the horizontal operating position.*

### Lowering the Platform



- ▶ Turn the rotary switches (27) and (29) simultaneously downward and hold them in this position until the platform has made contact with the ground.

*After the platform has touched the ground it tilts and adjusts to the ground.*

### Lifting the Platform



- ▶ Turn the rotary switches (27) and (29) simultaneously upward and hold them in this position until the platform has reached the vehicle loading floor height.

*The platform tilts to the horizontal or preset position before it is lifted.*

### Closing the Platform

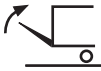

- ▶ Turn the rotary switches (28) and (29) simultaneously upward and hold them in this position until the platform is closed.

*If an optional load safety device is present, the platform closes approximately to 80° and is lowered a small amount. Finally, it moves to the vertical transport position and is lifted into the load safety device.*

- ▶ Close the platform interlock (if present).

### Retracting the Hydraulic Stabilizer Feet

- ▶ Turn the rotary switch (30) upward until the stabilizer feet are completely retracted.

## A Operation Using Two-hand Control with a Hydraulic Underrun Bumper

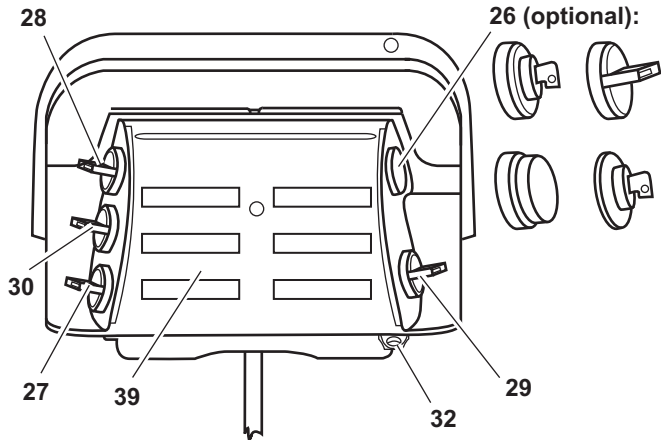

- 26** Optional: key control, rotary switch, emergency-off pushbutton, E30 key
- 27** Rotary switch: lift/lower
- 28** Rotary switch: open/close
- 29** Rotary switch: additional pushbutton
- 30** Rotary switch: lift/lower the underrun bumper
- 32** Locking lug
- 39** Operating panel

### DANGER!



#### Risk of accidents and injury!

If the instructions in chapter “General Operation” are not observed during operation of the tail lift, personal injuries and material damage can occur.

- ▶ Before operating the tail lift, read chapter “General Operation” from p. 24.

#### Lifting the Hydraulic Underrun Bumper

- ▶ Turn the rotary switch (**30**) upwards until the underrun bumper has reached its upper end position.

### Opening the Platform



- ▶ Loosen the platform interlock (if present).
- ▶ Turn the rotary switches **(27)** and **(29)** simultaneously downward and hold them down until the platform has reached the horizontal operating position.

*If an optional load safety device is present, the platform is lowered and then unfolds to the horizontal operating position.*

### Lowering the Platform



- ▶ Turn the rotary switches **(27)** and **(29)** simultaneously downward and hold them in this position until the platform has made contact with the ground.

*After the platform has touched the ground it tilts and adjusts to the ground.*

### Lifting the Platform



- ▶ Turn the rotary switches **(27)** and **(29)** simultaneously upward and hold them in this position until the platform has reached the vehicle loading floor height.

*The platform tilts to the horizontal or preset position before it is lifted.*

### Closing the Platform



- ▶ Turn the rotary switches **(28)** and **(29)** simultaneously upward and hold them in this position until the platform is closed.

*If an optional load safety device is present, the platform closes approximately to 80° and is lowered a small amount. Finally, it moves to the vertical transport position and is lifted into the load safety device.*

- ▶ Close the platform interlock (if present).

### Lowering the Hydraulic Underrun Bumper

- ▶ Turn the rotary switch **(30)** downwards until the underrun bumper has reached its lower end position.

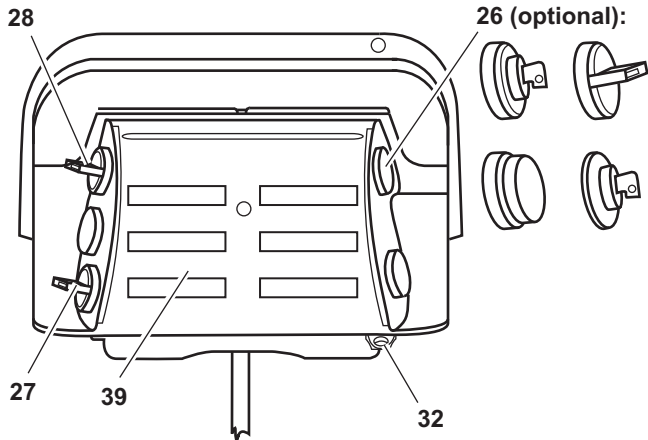
**A E** Operation Using One-hand Control

**26** Optional: key control, rotary switch, emergency-off pushbutton, E30 key

**27** Rotary switch: lift/lower

**28** Rotary switch: open/close

**32** Locking lug

**39** Operating panel

**DANGER!****Risk of accidents and injury!**

If the instructions in chapter “General Operation” are not observed during operation of the tail lift, personal injuries and material damage can occur.

- ▶ Before operating the tail lift, read chapter “General Operation” from p. 24.

### Opening the Platform



- ▶ Loosen the platform interlock (if present).
- ▶ Turn the rotary switch **(28)** downward and hold it in this position until the platform has reached the horizontal operating position.

*If an optional load safety device is present, the platform is lowered and then unfolds to the horizontal operating position.*

### Lowering the Platform



- ▶ Turn the rotary switch **(27)** upward and hold it in this position until the platform is adjusted flush to the ground.

*After the platform has touched the ground it tilts and adjusts to the ground.*

### Lifting the Platform



- ▶ Turn the rotary switch **(27)** upward and hold it in this position until the platform has reached the vehicle loading floor height.

*The platform tilts to the horizontal or preset position before it is lifted.*

### Closing the Platform



- ▶ Turn the rotary switch **(28)** upward and hold it in this position until the platform is closed.

*If an optional load safety device is present, the platform closes approximately to 80° and is lowered a small amount. Finally, it moves to the vertical transport position and is lifted into the load safety device.*

- ▶ Close the platform interlock (if present).

## A Operation Using One-hand Control and Hydraulic Stabilizer Feet

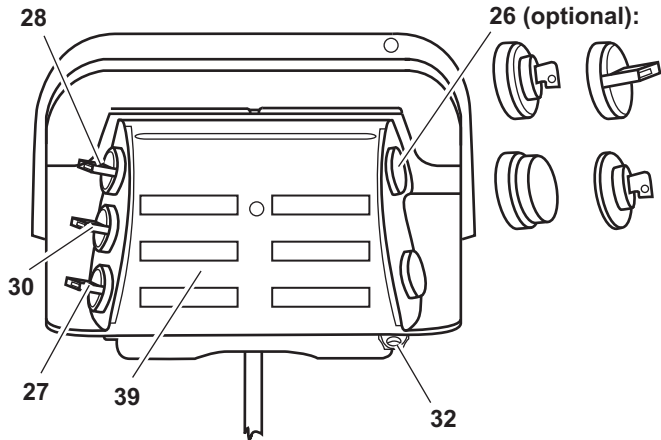

**26** Optional: key control, rotary switch, emergency-off pushbutton, E30 key

**27** Rotary switch: lift/lower

**28** Rotary switch: open/close

**30** Rotary switch: retract and extend

**32** Locking lug

**39** Operating panel

### DANGER!



#### Risk of accidents and injury!

If the instructions in chapter “General Operation” are not observed during operation of the tail lift, personal injuries and material damage can occur.

- ▶ Before operating the tail lift, read chapter “General Operation” from p. 24.

#### Extending the Hydraulic Stabilizer Feet

- ▶ Turn the rotary switch **(30)** downward until the stabilizer feet are extended almost to the ground.

### Opening the Platform



- ▶ Loosen the platform interlock (if present).
- ▶ Turn the rotary switch **(28)** downward and hold it in this position until the platform has reached the horizontal operating position.

*If an optional load safety device is present, the platform is lowered and then unfolds to the horizontal operating position.*

### Lowering the Platform



- ▶ Turn the rotary switch **(27)** upward and hold it in this position until the platform is adjusted flush to the ground.

*After the platform has touched the ground it tilts and adjusts to the ground.*

### Lifting the Platform



- ▶ Turn the rotary switch **(27)** upward and hold it in this position until the platform has reached the vehicle loading floor height.

*The platform tilts to the horizontal or preset position before it is lifted.*

### Closing the Platform



- ▶ Turn the rotary switch **(28)** upward and hold it in this position until the platform is closed.

*If an optional load safety device is present, the platform closes approximately to 80° and is lowered a small amount. Finally, it moves to the vertical transport position and is lifted into the load safety device.*

- ▶ Close the platform interlock (if present).

### Retracting the Hydraulic Stabilizer Feet

- ▶ Turn the rotary switch **(30)** upward until the stabilizer feet are completely retracted.

## A Operation Using Joystick

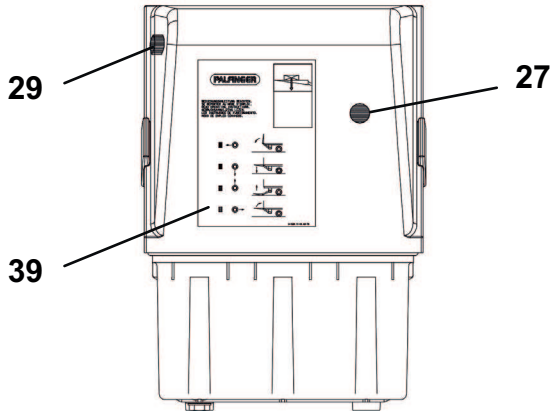

- 27 Joystick: lift/lower/open/close
- 29 Pushbutton: additional pushbutton
- 39 Operating panel

### DANGER!



#### Risk of accidents and injury!

If the instructions in chapter “General Operation” are not observed during operation of the tail lift, personal injuries and material damage can occur.

- ▶ Before operating the tail lift, read chapter “General Operation” from p. 24.

### Opening the Platform



- ▶ Loosen the platform interlock (if present).
- ▶ Press the pushbutton **(29)** and simultaneously move the joystick **(27)** to the left (direction of travel right) or to the right (direction of travel left) and hold them in this position until the platform has reached the horizontal operating position.

### Lowering the Platform



- ▶ Press the pushbutton **(29)** and simultaneously move the joystick downward and hold them in this position until the platform is adjusted flush to the ground.

*After the platform has touched the ground it tilts and adjusts to the ground.*

### Lifting the Platform



- ▶ Press the pushbutton **(29)** and simultaneously move the joystick **(27)** upward and hold them in this position until the platform has reached the vehicle loading floor height.

*The platform tilts to the horizontal or preset position before it is lifted.*

### Closing the Platform



- ▶ Press the pushbutton **(29)** and simultaneously move the joystick **(27)** to the right (direction of travel right) or to the left (direction of travel left) and hold them in this position until the platform is completely closed.
- ▶ Close the platform interlock (if present).

## C Operation Using Two-hand Control and Pushbuttons

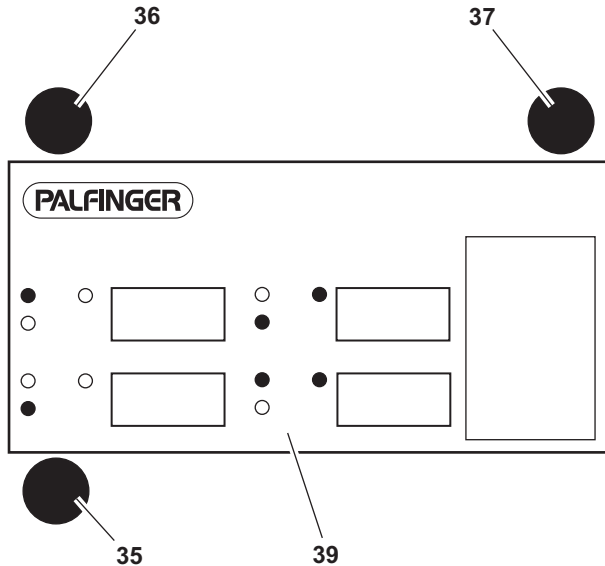

- 35** Pushbutton: lower/lift
- 36** Pushbutton: open/close
- 37** Pushbutton: lift/close
- 39** Operating panel

### DANGER!



#### Risk of accidents and injury!

If the instructions in chapter “General Operation” are not observed during operation of the tail lift, personal injuries and material damage can occur.

- ▶ Before operating the tail lift, read chapter “General Operation” from p. 24.

### Opening the Platform



- ▶ Loosen the platform interlock (if present).
- ▶ Press and hold pushbutton **(36)** until the platform has reached the horizontal operating position.

### Lowering the Platform



- ▶ Press and hold pushbutton **(35)** until the platform has made contact with the ground.

*After the platform has touched the ground it tilts and adjusts to the ground.*

### Lifting the Platform



- ▶ Press and hold pushbuttons **(35)** and **(37)** simultaneously until the platform has reached the vehicle loading floor height.

*The platform tilts to the horizontal or preset position before it is lifted.*

### Closing the Platform



- ▶ Press and hold pushbuttons **(36)** and **(37)** simultaneously until the platform has reached the vertical transport position.
- ▶ Close the platform interlock (if present).

## F Operation Using Two-hand Control

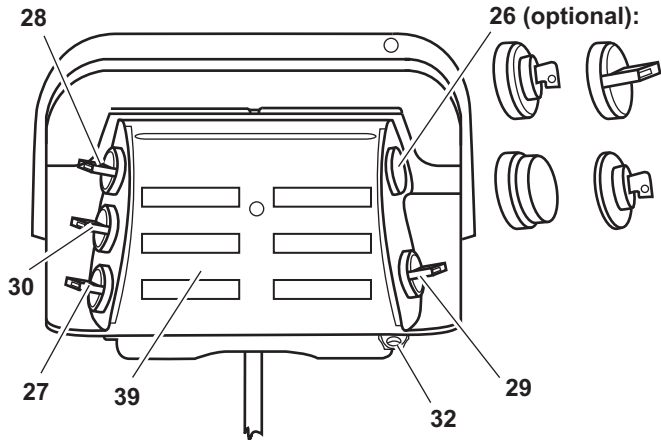

- 26** Optional: key control, rotary switch, emergency-off pushbutton, E30 key
- 27** Rotary switch: lift/lower
- 28** Rotary switch: open/close
- 29** Rotary switch: additional pushbutton
- 30** Rotary switch: Retract and extend
- 32** Locking lug
- 39** Operating panel

### DANGER!



#### Risk of accidents and injury!

If the instructions in chapter "General Information" are not observed during operation of the tail lift, personal injuries and material damage can occur.

- ▶ Before operating the tail lift, read chapter "General Operation" from p. 24.

#### Extending and Folding Out the Platform

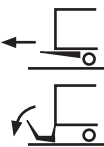

- ▶ Loosen the platform interlock (if present).
- ▶ Turn the rotary switches **(27)** and **(29)** simultaneously downward and hold them in this position until the platform has been lowered.

*The platform is lowered so that it can be extended without obstruction.*

- ▶ Turn the rotary switch **(30)** downward and hold it in this position until the platform is completely extended.
- ▶ Turn the rotary switches **(27)** and **(29)** simultaneously downward and hold them in this position until the folded platform has made contact with the ground.
- ▶ Protect your hands with gloves.
- ▶ Pull the handle with both hands to unfold the folding part of the platform.

### Lowering the Platform



- ▶ Turn the rotary switches **(27)** and **(29)** simultaneously downward and hold them in this position until the platform has made contact with the ground and is adjusted flush to the ground.

*After the platform has touched the ground it tilts and adjusts to the ground.*

### Lifting the Platform



- ▶ Turn the rotary switches **(27)** and **(29)** simultaneously upward and hold them in this position until the platform has reached the vehicle loading floor height.

*The platform tilts to the horizontal or preset position before it is lifted into the loading position.*

### Folding In and Retracting the Platform

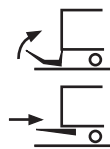

- ▶ Protect your hands with gloves.
- ▶ Pull the handle with both hands to fold back the folding part of the platform.
- ▶ Close the platform interlock (if present).
- ▶ Turn the rotary switches **(27)** and **(29)** simultaneously upward and hold them in this position until the platform has reached the retraction height.
- ▶ Turn the rotary switch **(30)** upward and hold it in this position until the platform is completely retracted. Observe that the platform can be retracted without obstruction.
- ▶ Turn the rotary switches **(27)** and **(29)** simultaneously upward and hold them in this position until the platform has reached the vibration safeguard.

## F Operation with Two-hand Control easy move®

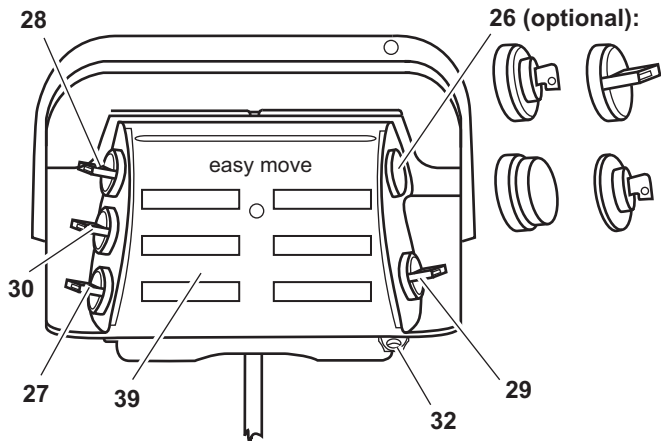

- 26 Optional: key control, rotary switch, emergency-off pushbutton, E30 key
- 27 Rotary switch: lift/lower
- 28 Rotary switch: open/close
- 29 Rotary switch: additional pushbutton
- 30 Rotary switch: Retract and extend
- 32 Locking lug
- 39 Operating panel

### DANGER!



#### Risk of accidents and injury!

If the instructions in chapter "General Information" are not observed during operation of the tail lift, personal injuries and material damage can occur.

- ▶ Before operating the tail lift, read chapter "General Operation" from p. 24.

#### Extending and Folding Out the Platform

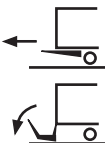

- ▶ Loosen the platform interlock (if present).
- ▶ Turn the rotary switch (30) downward and hold it in this position until the platform is extended.

*The platform is lowered so that it can be extended without obstruction and is extended.*

- ▶ Turn the rotary switches **(27)** and **(29)** simultaneously downward and hold them in this position until the folded platform has made contact with the ground.
- ▶ Protect your hands with gloves.
- ▶ Pull the handle with both hands to unfold the folding part of the platform.

### Lowering the Platform



- ▶ Turn the rotary switches **(27)** and **(29)** simultaneously downward and hold them in this position until the platform has made contact with the ground and is adjusted flush to the ground.

*After the platform has touched the ground it tilts and adjusts to the ground.*

### Lifting the Platform



- ▶ Turn the rotary switches **(27)** and **(29)** simultaneously upward and hold them in this position until the platform has reached the vehicle loading floor height.

*The platform tilts to the horizontal or preset position before it is lifted into the loading position.*

### Folding In and Retracting the Platform

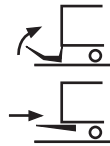

- ▶ Protect your hands with gloves.
- ▶ Pull the handle with both hands to fold back the folding part of the platform.
- ▶ Turn the rotary switch **(30)** upward and hold it in this position until the platform is completely retracted. Observe that the platform can be retracted without obstruction.

*The folded platform lifts or lowers automatically until the optimum retraction position is reached. The platform then retracts until the end position and lifts into the vibration safeguard.*

- ▶ Close the platform interlock (if present).

## F Operation with One-hand Control

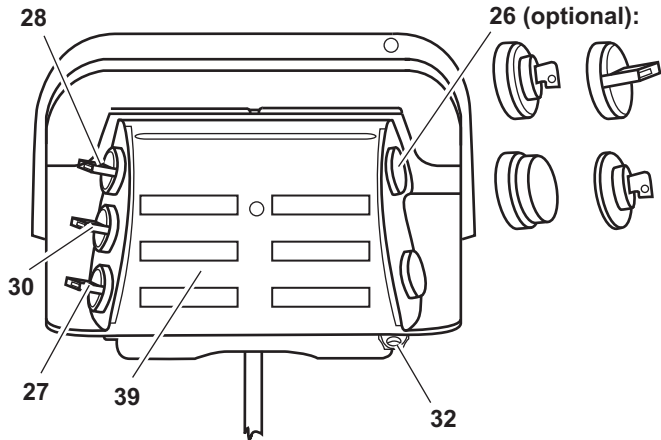

- 26** Optional: key control, rotary switch, emergency-off pushbutton, E30 key
- 27** Rotary switch: lift/lower
- 28** Rotary switch: open/close
- 30** Rotary switch: Retract and extend
- 32** Locking lug
- 39** Operating panel

### DANGER!



#### Risk of accidents and injury!

If the instructions in chapter "General Information" are not observed during operation of the tail lift, personal injuries and material damage can occur.

- ▶ Before operating the tail lift, read chapter "General Operation" from p. 24.

#### Extending and Folding Out the Platform

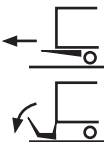

- ▶ Loosen the platform interlock (if present).
- ▶ Turn the rotary switch (**27**) downward and hold it in this position until the platform has been lowered.

*The platform is lowered so that it can be extended without obstruction.*

- ▶ Turn the rotary switch **(30)** downward and hold it in this position until the platform is completely extended.
- ▶ Turn the rotary switch **(27)** downward and hold it in this position until the folded platform has touched the ground.
- ▶ Protect your hands with gloves.
- ▶ Pull the handle with both hands to unfold the folding part of the platform.

### Lowering the Platform



- ▶ Turn the rotary switch **(27)** downward and hold it in this position until the platform has made contact with the ground and is adjusted flush to the ground.

*After the platform has touched the ground it tilts and adjusts to the ground.*

### Lifting the Platform



- ▶ Turn the rotary switch **(27)** upward and hold it in this position until the platform has reached the vehicle loading floor height.

*The platform tilts to the horizontal or preset position before it is lifted into the loading position.*

### Folding In and Retracting the Platform

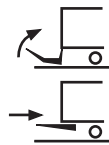

- ▶ Protect your hands with gloves.
- ▶ Pull the handle with both hands to fold back the folding part of the platform.
- ▶ Turn the rotary switch **(27)** upward and hold it in this position until the platform has reached the retraction height.
- ▶ Turn the rotary switch **(30)** upward and hold it in this position until the platform is completely retracted. Observe that the platform can be retracted without obstruction.
- ▶ Turn the rotary switch **(27)** upward and hold it in this position until the platform has reached the vibration safeguard.
- ▶ Close the platform interlock (if present).

## F Operation with One-hand Control easy move®

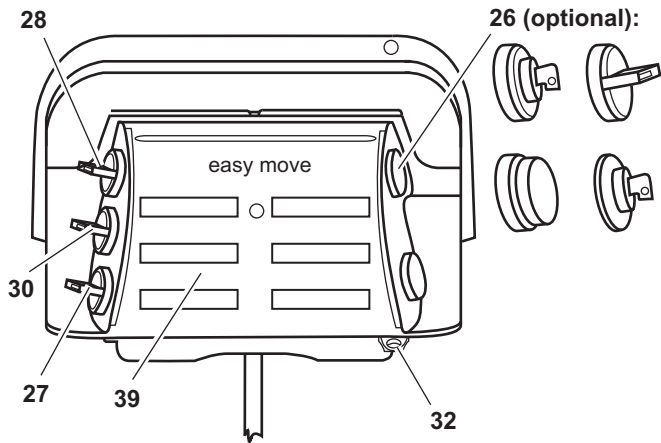

- 26 Optional: key control, rotary switch, emergency-off pushbutton, E30 key
- 27 Rotary switch: lift/lower
- 28 Rotary switch: open/close
- 30 Rotary switch: Retract and extend
- 32 Locking lug
- 39 Operating panel

### DANGER!



#### Risk of accidents and injury!

If the instructions in chapter "General Information" are not observed during operation of the tail lift, personal injuries and material damage can occur.

- ▶ Before operating the tail lift, read chapter "General Operation" from p. 24.

#### Extending and Folding Out the Platform

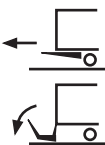

- ▶ Loosen the platform interlock (if present).
- ▶ Turn the rotary switch (30) downward and hold it in this position until the platform is extended.

*The platform is lowered so that it can be extended without obstruction and is extended.*

- ▶ Turn the rotary switch **(27)** downward and hold it in this position until the folded platform has touched the ground.
- ▶ Protect your hands with gloves.
- ▶ Pull the handle with both hands to unfold the folding part of the platform.

### Lowering the Platform



- ▶ Turn the rotary switch **(27)** downward and hold it in this position until the platform has made contact with the ground and is adjusted flush to the ground.

*After the platform has touched the ground it tilts and adjusts to the ground.*

### Lifting the Platform



- ▶ Turn the rotary switch **(27)** upward and hold it in this position until the platform has reached the vehicle loading floor height.

*The platform tilts to the horizontal or preset position before it is lifted into the loading position.*

### Folding In and Retracting the Platform

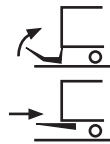

- ▶ Protect your hands with gloves.
- ▶ Pull the handle with both hands to fold back the folding part of the platform.
- ▶ Turn the rotary switch **(30)** upward and hold it in this position until the platform is completely retracted. Observe that the platform can be retracted without obstruction.

*The folded platform lifts or lowers automatically until the optimum retraction position is reached. The platform then retracts until the end position and lifts into the vibration safe-guard.*

- ▶ Close the platform interlock (if present).

## F Operation Using Two-hand Control for MBB R 1500 L FLAT

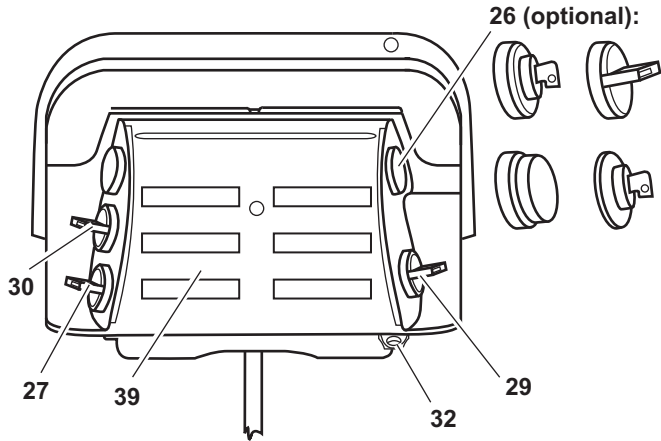

- 26** Optional: Key control, rotary switch, emergency-off pushbutton, E30 key
- 27** Rotary switch: lift/lower
- 29** Rotary switch: additional pushbutton
- 30** Rotary switch: Retract and extend
- 32** Locking lug
- 39** Operating panel

### DANGER!



#### Risk of accidents and injury!

If the instructions in chapter "General Information" are not observed during operation of the tail lift, personal injuries and material damage can occur.

- ▶ Before operating the tail lift, read chapter "General Operation" from p. 24.

#### Extending and Folding Out the Platform

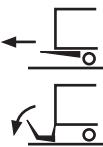

- ▶ Loosen the platform interlock (if present).
- ▶ Turn the rotary switches (**27**) and (**29**) simultaneously downward and hold them in this position until the platform has been lowered.

*The platform is lowered so that it can be extended without obstruction.*

- ▶ Turn the rotary switch **(30)** downward and hold it in this position until the platform is completely extended.
- ▶ Turn the rotary switches **(27)** and **(29)** simultaneously downward and hold them in this position until the folded platform has made contact with the ground.
- ▶ Protect your hands with gloves.
- ▶ Pull the handle with both hands to unfold the folding part of the platform.

### Lowering the Platform



- ▶ Turn the rotary switches **(27)** and **(29)** simultaneously downward and hold them in this position until the platform has made contact with the ground and is adjusted flush to the ground.

### Lifting the Platform



- ▶ Turn the rotary switches **(27)** and **(29)** simultaneously upward and hold them in this position until the platform has reached the vehicle loading floor height.

### Folding In and Retracting the Platform

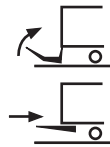

- ▶ Protect your hands with gloves.
- ▶ Pull the handle with both hands to fold back the folding part of the platform.
- ▶ Close the platform interlock (if present).
- ▶ Turn the rotary switches **(27)** and **(29)** simultaneously upward and hold them in this position until the platform has reached the retraction height.
- ▶ Turn the rotary switch **(30)** upward and hold it in this position until the platform is completely retracted. Observe that the platform can be retracted without obstruction.
- ▶ Turn the rotary switches **(27)** and **(29)** simultaneously upward and hold them in this position until the platform has reached the vibration safeguard.

## F Operation Using One-Hand Control for MBB R 1500 L FLAT

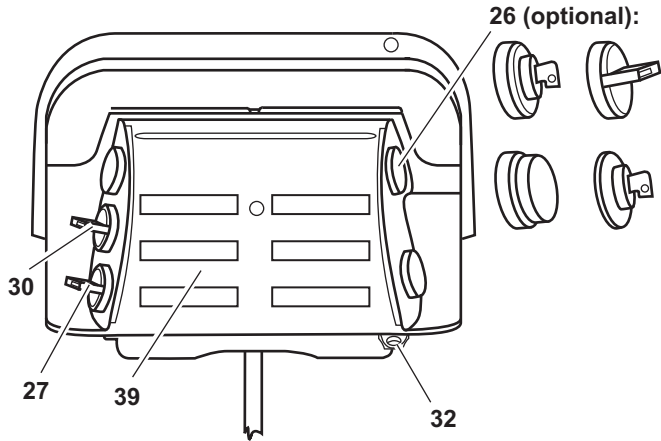

- 26** Optional: key control, rotary switch, emergency-off pushbutton, E30 key
- 27** Rotary switch: lift/lower
- 30** Rotary switch: Retract and extend
- 32** Locking lug
- 39** Operating panel

### DANGER!



#### Risk of accidents and injury!

If the instructions in chapter "General Information" are not observed during operation of the tail lift, personal injuries and material damage can occur.

- ▶ Before operating the tail lift, read chapter "General Operation" from p. 24.

#### Extending and Folding Out the Platform

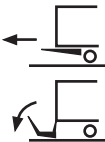

- ▶ Loosen the platform interlock (if present).
- ▶ Turn the rotary switch (**27**) downward and hold it in this position until the platform has been lowered.  
*The platform is lowered so that it can be extended without obstruction.*
- ▶ Turn the rotary switch (**30**) downward and hold it in this position until the platform is completely extended.

- ▶ Turn the rotary switch **(27)** downward and hold it in this position until the folded platform has touched the ground.
- ▶ Protect your hands with gloves.
- ▶ Pull the handle with both hands to unfold the folding part of the platform.

### Lowering the Platform



- ▶ Turn the rotary switch **(27)** downward and hold it in this position until the platform has made contact with the ground and is adjusted flush to the ground.

### Lifting the Platform



- ▶ Turn the rotary switch **(27)** upward and hold it in this position until the platform has reached the vehicle loading floor height.

### Folding In and Retracting the Platform

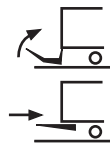

- ▶ Protect your hands with gloves.
- ▶ Pull the handle with both hands to fold back the folding part of the platform.
- ▶ Turn the rotary switch **(27)** upward and hold it in this position until the platform has reached the retraction height.
- ▶ Turn the rotary switch **(30)** upward and hold it in this position until the platform is completely retracted. Observe that the platform can be retracted without obstruction.
- ▶ Turn the rotary switch **(27)** upward and hold it in this position until the platform has reached the vibration safeguard.
- ▶ Close the platform interlock (if present).

## **G** Operation Using Two-hand Control for MBB R 1500 SH - R 2000 LH (Double-folded Platform with Cross Member)

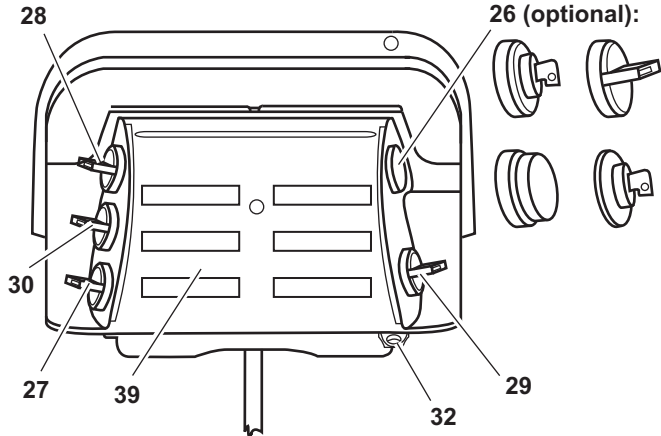

- 26** Optional: key control, rotary switch, emergency-off pushbutton, E30 key
- 27** Rotary switch: lift/lower
- 28** Rotary switch: open/close
- 29** Rotary switch: additional pushbutton
- 30** Rotary switch: retract and extend
- 32** Locking lug
- 39** Operating panel

### **DANGER!**



#### **Risk of accidents and injury!**

If the instructions in chapter “General Operation” are not observed during operation of the tail lift, personal injuries and material damage can occur.

- Before operating the tail lift, read chapter “General Operation” from p. 24.

### Extending and Folding Out the Platform

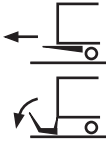

- ▶ Loosen the platform interlock (if present).
- ▶ Turn the rotary switch **(30)** downward and hold it in this position until the platform is folded out once.

*The platform is slightly lowered and then extends. Subsequently it is lowered to the ground and unfolds once.*

- ▶ Protect your hands with gloves.
- ▶ Pull the handle with both hands to unfold the folding part of the platform.

### Lifting the Platform



- ▶ Turn the rotary switches **(27)** and **(29)** simultaneously upward and hold them in this position until the platform has reached the vehicle loading floor height.

*The platform tilts to the horizontal or preset position before it is lifted into the loading position.*

### Lowering the Platform



- ▶ Turn the rotary switches **(27)** and **(29)** simultaneously downward and hold them in this position until the platform has made contact with the ground and is adjusted flush to the ground.

*After the platform has touched the ground it tilts and adjusts to the ground.*

### Setting the BDF Position

- ▶ Turn the rotary switches **(27)** and **(29)** simultaneously upward and hold them in this position until the platform has reached the vehicle loading floor height.
- ▶ Turn the rotary switch **(30)** upward and hold it in this position until the platform has reached the loading position.
- ▶ Shift the movable stop on the guide rail until the outer initiator is dampened.

### Moving to the BDF Position

- ▶ Turn the rotary switches **(27)** and **(29)** simultaneously upward and hold them in this position until the torsion frame is located above its horizontal position.
- ▶ Turn the rotary switch **(30)** upwards.  
*The platform moves to the preset BDF position.*
- ▶ Turn the rotary switches **(27)** and **(29)** simultaneously upward and hold them in this position until the platform has reached the loading position.

### Folding In and Retracting the Platform

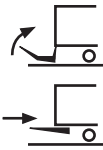

- ▶ Turn the rotary switches **(27)** and **(29)** simultaneously downward and hold them in this position until the platform has reached the ground.
- ▶ Protect your hands with gloves.
- ▶ Pull the handle with both hands to fold back the folding part of the platform.
- ▶ Close the platform interlock (if present).
- ▶ Turn the rotary switch **(30)** upward and hold it in this position until the platform has reached the vibration safeguard.  
*The platform automatically folds over and then lifts into the retraction position. Subsequently it retracts completely and lifts into the vibration safeguard.*



## **G** Operation Using Two-hand Control for MBB R 750 SM - R 2000 LM (Double-folded Platform without Cross Member)

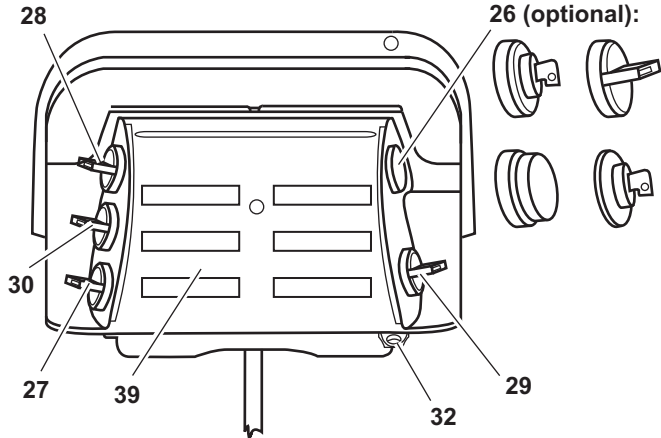

- 26** Optional: key control, rotary switch, emergency-off pushbutton, E30 key
- 27** Rotary switch: lift/lower
- 28** Rotary switch: open/close
- 29** Rotary switch: additional pushbutton
- 30** Rotary switch: retract and extend
- 32** Locking lug
- 39** Operating panel

### **DANGER!**



#### **Risk of accidents and injury!**

If the instructions in chapter “General Operation” are not observed during operation of the tail lift, personal injuries and material damage can occur.

- Before operating the tail lift, read chapter “General Operation” from p. 24.

### Extending and Folding Out the Platform

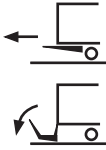

- ▶ Loosen the platform interlock (if present).
- ▶ Turn the rotary switch **(30)** downward and hold it in this position until the platform has reached the vertical position.  
*The platform is slightly lowered and then extends. Subsequently it lowers to the ground and tilts into an approximate vertical position.*
- ▶ Protect your hands with gloves.
- ▶ Swivel the platform with both hands forward by approximately 20°.
- ▶ Turn the rotary switch **(30)** downward and hold it in this position until the platform touches the ground.  
*The platform lowers to the ground and then unfolds once.*
- ▶ Protect your hands with gloves.
- ▶ Pull the handle with both hands to unfold the second folding part of the platform.

### Lifting the Platform



- ▶ Turn the rotary switches **(27)** and **(29)** simultaneously upward and hold them in this position until the platform has reached the vehicle loading floor height.  
*The platform tilts to the horizontal or preset position before it is lifted into the loading position.*

### Lowering the Platform



- ▶ Turn the rotary switches **(27)** and **(29)** simultaneously downward and hold them in this position until the platform has made contact with the ground and is adjusted flush to the ground.  
*After the platform has touched the ground it tilts and adjusts to the ground.*

### Setting the BDF Position

- ▶ Turn the rotary switches **(27)** and **(29)** simultaneously upward and hold them in this position until the platform has reached the vehicle loading floor height.
- ▶ Turn the rotary switch **(30)** upward and hold it in this position until the platform has reached the loading position.
- ▶ Shift the movable stop on the guide rail until the outer initiator is dampened.

### Moving to the BDF Position

- ▶ Turn the rotary switches **(27)** and **(29)** simultaneously upward and hold them in this position until the torsion frame is located above its horizontal position.
- ▶ Turn the rotary switch **(30)** upwards.  
*The platform moves to the preset BDF position.*
- ▶ Turn the rotary switches **(27)** and **(29)** simultaneously upward and hold them in this position until the platform has reached the loading position.

### Folding In and Retracting the Platform

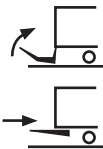

- ▶ Turn the rotary switches **(27)** and **(29)** simultaneously downward and hold them in this position until the platform has reached the ground.
- ▶ Protect your hands with gloves.
- ▶ Fold in the link bridge (if present).
- ▶ Pull the handle with both hands to fold back the folding part of the platform.
- ▶ Turn the rotary switch **(30)** upward and hold it in this position until the platform has reached the vertical position.
- ▶ Tilt the platform with both hands forward by approximately 20°.
- ▶ Turn the rotary switch **(30)** upward and hold it in this position until the platform has reached the vibration safeguard.  
*After the platform folded over automatically, it lifts itself into the vibration safeguard.*
- ▶ Close the platform interlock (if present).



## **G** Operation Using Two-hand Control for MBB R 750 SM - R 2000 LM (Double-folded Platform with Cross Member)

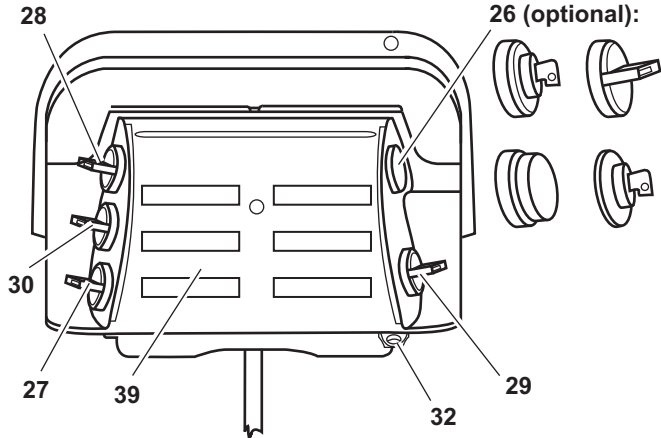

- 26** Optional: key control, rotary switch, emergency-off pushbutton, E30 key
- 27** Rotary switch: lift/lower
- 28** Rotary switch: open/close
- 29** Rotary switch: additional pushbutton
- 30** Rotary switch: retract and extend
- 32** Locking lug
- 39** Operating panel

### **DANGER!**



#### **Risk of accidents and injury!**

If the instructions in chapter “General Operation” are not observed during operation of the tail lift, personal injuries and material damage can occur.

- Before operating the tail lift, read chapter “General Operation” from p. 24.

### Extending and Folding Out the Platform

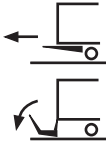

- ▶ Loosen the platform interlock (if present).
- ▶ Turn the rotary switches **(27)** and **(29)** simultaneously downward and hold them in this position until the platform has been lowered.
 

*The platform is lowered so that it can be extended without obstruction.*
- ▶ Turn the rotary switch **(30)** downward and hold it in this position until the platform is completely extended.
- ▶ Turn the rotary switches **(27)** and **(29)** simultaneously downward and hold them in this position until the folded platform has made contact with the ground.
- ▶ Protect your hands with gloves.
- ▶ Pull the platform edge with both hands to unfold the platform to the rear.
- ▶ Pull the folding part of the platform with both hands to unfold it to the rear.

### Lowering the Platform



- ▶ Turn the rotary switches **(27)** and **(29)** simultaneously downward and hold them in this position until the platform has made contact with the ground and is adjusted flush to the ground.
 

*After the platform has touched the ground it tilts and adjusts to the ground.*

### Lifting the Platform



- ▶ Turn the rotary switches **(27)** and **(29)** simultaneously upward and hold them in this position until the platform has reached the vehicle loading floor height.
 

*The platform tilts to the horizontal or preset position before it is lifted into the loading position.*

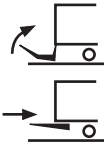

### Folding In and Retracting the Platform

- ▶ Protect your hands with gloves.
- ▶ Grasp the platform edge with both hands to fold back the platform.
- ▶ Pull the folding part of the platform with both hands to fold it back.
- ▶ Close the platform interlock (if present).
- ▶ Swivel the platform up to the roller at the support tube.
- ▶ Turn the rotary switches **(27)** and **(29)** simultaneously upward and hold them in this position until the platform has reached the retraction height.
- ▶ Turn the rotary switch **(30)** upward and hold it in this position until the platform is completely retracted. Observe that the platform can be retracted without obstruction.

Turn the rotary switches **(27)** and **(29)** simultaneously upward and hold them in this position until the platform has reached the vibration safeguard.



## K Operation Using Two-hand Control

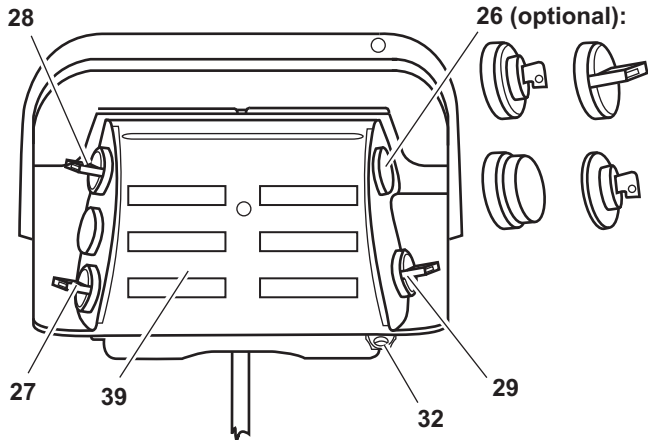

- 26 Optional: key control, rotary switch, emergency-off pushbutton, E30 key
- 27 Rotary switch: lift/lower
- 28 Rotary switch: open/close
- 29 Rotary switch: additional pushbutton
- 32 Locking lug
- 39 Operating panel

### DANGER!



#### Risk of accidents and injury!

If the instructions in chapter “General Operation” are not observed during operation of the tail lift, personal injuries and material damage can occur.

- ▶ Before operating the tail lift, read chapter “General Operation” from p. 24.

#### Folding Out the Platform



- ▶ Loosen the platform interlock (if present).
- ▶ Turn the rotary switches (27) and (29) simultaneously downward and hold them in this position until the platform has almost reached the vertical position.  
*The platform is lowered slightly and then tilts via the guide pulley almost to the vertical position.*
- ▶ Protect your hands with gloves.

- ▶ Pull the handle with both hands to fold out the platform to the rear.
- ▶ Turn the rotary switches **(28)** and **(29)** simultaneously downward and hold them in this position until the platform has reached the horizontal position.
- ▶ Fold the folding part of the platform with both hands to the operating position.

### Lowering the Platform



- ▶ Turn the rotary switches **(27)** and **(29)** simultaneously downward and hold them in this position until the platform has made contact with the ground.

*After the platform has touched the ground it tilts and adjusts to the ground.*

### Lifting the Platform



- ▶ Turn the rotary switches **(27)** and **(29)** simultaneously upward and hold them in this position until the platform has reached the loading position.

### Folding In the Platform



- ▶ Make sure that the platform is in horizontal position touching the ground.
- ▶ Protect your hands with gloves.
- ▶ Unfold the folding part of the platform with both hands from the operating position onto the stationary part of the platform.
- ▶ Turn the rotary switches **(28)** and **(29)** simultaneously upward and hold them in this position until the platform has reached the vertical position.
- ▶ Protect your hands with gloves.
- ▶ Use both hands to push the platform against the guide pulley.
- ▶ Turn the rotary switches **(27)** and **(29)** simultaneously upward and hold them in this position until the platform has reached the transport position.
- ▶ Close the platform interlock (if present).

## K Operation Using One-hand Control

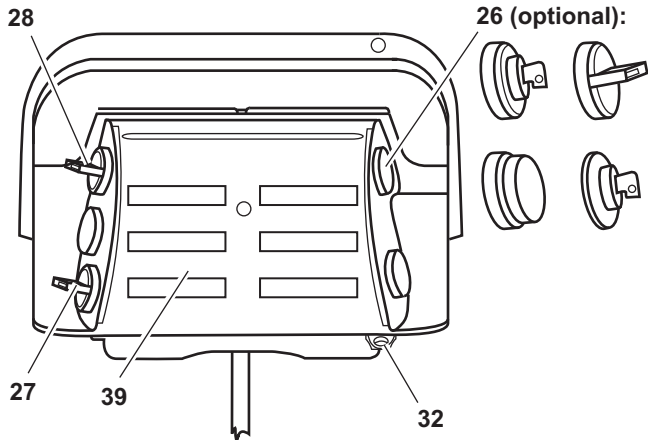

- 26** Optional: key control, rotary switch, emergency-off pushbutton, E30 key
- 27** Rotary switch: lift/lower
- 28** Rotary switch: open/close
- 32** Locking lug
- 39** Operating panel

### DANGER!



#### Risk of accidents and injury!

If the instructions in chapter “General Operation” are not observed during operation of the tail lift, personal injuries and material damage can occur.

- ▶ Before operating the tail lift, read chapter “General Operation” from p. 24.

#### Folding Out the Platform



- ▶ Loosen the platform interlock (if present).
- ▶ Turn the rotary switch (**27**) downward and hold it in this position until the platform has reached the vertical position.  
*The platform is lowered slightly and then tilts via the guide pulley almost to the vertical position.*
- ▶ Protect your hands with gloves.
- ▶ Pull the handle with both hands to fold out the platform to the rear.

- ▶ Turn the rotary switch **(28)** downward and hold it in this position until the platform has reached the horizontal position.
- ▶ Fold the folding part of the platform with both hands to the operating position.

### Lifting the Platform



- ▶ Turn the rotary switch **(27)** upward and hold it in this position until the platform has reached the loading position.

### Lowering the Platform



- ▶ Turn the rotary switch **(27)** upward and hold it in this position until the platform is adjusted flush to the ground.  
*After the platform has touched the ground it tilts and adjusts to the ground.*

### Folding In the Platform

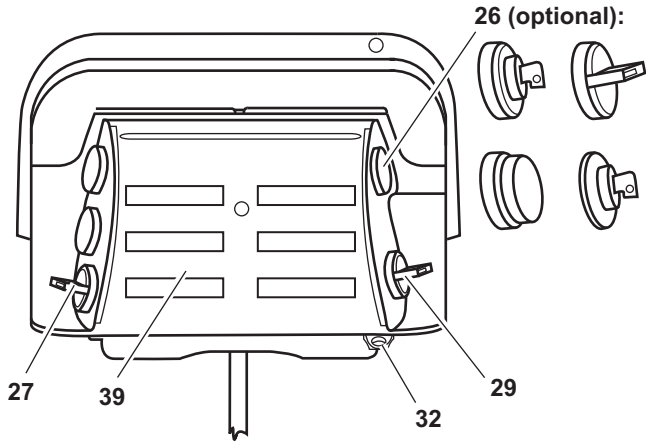

- ▶ Make sure that the platform is in horizontal position touching the ground.
- ▶ Protect your hands with gloves.
- ▶ Unfold the folding part of the platform with both hands from the operating position onto the stationary part of the platform.
- ▶ Turn the rotary switch **(28)** upward and hold it in this position until the platform has reached the vertical position.  
*The platform tilts from the horizontal to the vertical position.*
- ▶ Protect your hands with gloves.
- ▶ Use both hands to push the platform against the guide pulley.
- ▶ Turn the rotary switch **(27)** upward and hold it in this position until the platform has reached the transport position.
- ▶ Close the platform interlock (if present).

**B L M** Operation Using Two-hand Control

- 26** Optional: key control, rotary switch, emergency-off pushbutton, E30 key
- 27** Rotary switch: lift/lower
- 29** Rotary switch: additional pushbutton
- 32** Locking lug
- 39** Operating panel

**DANGER!****Risk of accidents and injury!**

If the instructions in chapter “General Operation” are not observed during operation of the tail lift, personal injuries and material damage can occur.

- ▶ Before operating the tail lift, read chapter “General Operation” from p. 24.

### Folding Out the Platform



- ▶ Loosen the platform interlock (if present).
- ▶ Turn the rotary switches **(27)** and **(29)** simultaneously downward and hold them in this position until the platform has made contact with the ground.
- ▶ Protect your hands with gloves.
- ▶ Pull the handle with both hands to unfold the folding part of the platform.

### Lifting the Platform



- ▶ Turn the rotary switches **(27)** and **(29)** simultaneously upward and hold them in this position until the platform has reached the loading position.

*The platform tilts to the horizontal or preset position and is then lifted.*

### Lowering the Platform



- ▶ Turn the rotary switches **(27)** and **(29)** simultaneously downward and hold them in this position until the platform has made contact with the ground.

*After the platform has touched the ground it tilts and adjusts to the ground.*

### Folding In the Platform



- ▶ Make sure that the platform is in horizontal position touching the ground.
- ▶ Protect your hands with gloves.
- ▶ Unfold the folding part of the platform with both hands from the operating position onto the stationary part of the platform.
- ▶ Close the platform interlock (if present).
- ▶ Swivel the platform up to the roller at the support tube.
- ▶ Turn the rotary switches **(27)** and **(29)** simultaneously upward and hold them in this position until the platform is folded away under the vehicle.

*The platform lifts and is moved under the vehicle.*

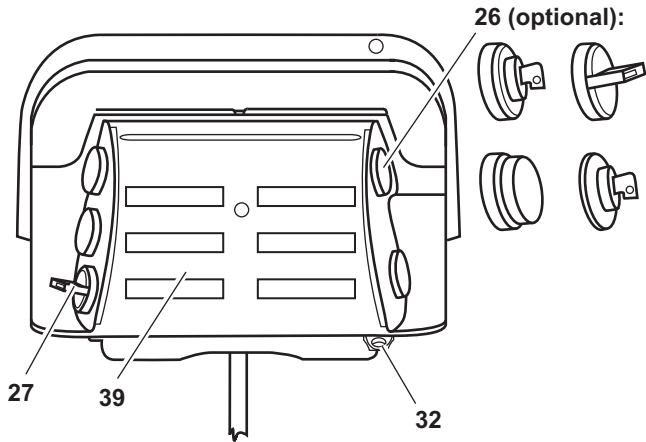
**B L M** Operation Using One-hand Control

- 26** Optional: key control, rotary switch, emergency-off pushbutton, E30 key
- 27** Rotary switch: lift/lower
- 32** Locking lug
- 39** Operating panel

**DANGER!****Risk of accidents and injury!**

If the instructions in chapter “General Operation” are not observed during operation of the tail lift, personal injuries and material damage can occur.

- ▶ Before operating the tail lift, read chapter “General Operation” from p. 24.

### Folding Out the Platform



- ▶ Loosen the platform interlock (if present).
- ▶ Turn the rotary switch (27) upward and hold it in this position until the platform is adjusted flush to the ground.
- ▶ Protect your hands with gloves.
- ▶ Pull the handle with both hands to unfold the folding part of the platform.

### Lifting the Platform



- ▶ Turn the rotary switch (27) upward and hold it in this position until the platform has reached the loading position.  
*The platform tilts to the horizontal or preset position and is then lifted.*

### Lowering the Platform



- ▶ Turn the rotary switch (27) upward and hold it in this position until the platform is adjusted flush to the ground.  
*After the platform has touched the ground it tilts and adjusts to the ground.*

### Folding In the Platform

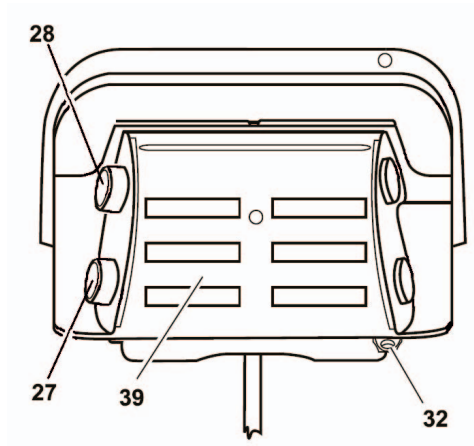

- ▶ Make sure that the platform is in horizontal position touching the ground.
- ▶ Protect your hands with gloves.
- ▶ Unfold the folding part of the platform with both hands from the operating position onto the stationary part of the platform.
- ▶ Close the platform interlock (if present).
- ▶ Swivel the platform up to the roller at the support tube.
- ▶ Turn the rotary switch (27) upward and hold it in this position until the platform is folded away under the vehicle.  
*The platform lifts and is moved under the vehicle.*

**M** Operation F 600 L

- 27 Pushbutton: lower
- 28 Pushbutton: lift
- 32 Locking lug
- 39 Operating panel

**DANGER!****Risk of accidents and injury!**

If the instructions in chapter “General Operation” are not observed during operation of the tail lift, personal injuries and material damage can occur.

- ▶ Before operating the tail lift, read chapter “General Operation” from p. 24.

### Folding Out the Platform



- ▶ Loosen the platform interlock (if present).
- ▶ Press the pushbutton **(27)** and hold.
- ▶ Protect your hands with gloves.
- ▶ Pull the handle with both hands to unfold the folding part of the platform.

### Lifting the Platform



- ▶ Press the pushbutton **(28)** and hold it in this position until the platform has reached the loading position.  
*The platform tilts to the horizontal or preset position and is then lifted.*

### Lowering the Platform



- ▶ Press the pushbutton **(27)** and hold it in this position until the platform is adjusted flush to the ground.  
*After the platform has touched the ground it tilts and adjusts to the ground.*

### Folding In the Platform

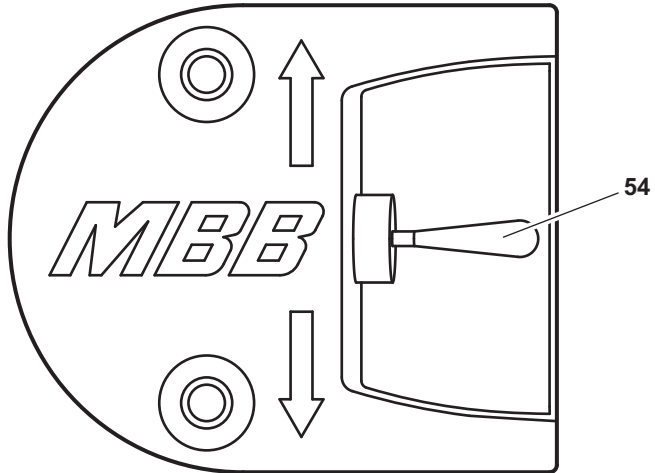

- ▶ Make sure that the platform is in horizontal position touching the ground.
- ▶ Protect your hands with gloves.
- ▶ Unfold the folding part of the platform with both hands from the operating position onto the stationary part of the platform.
- ▶ Close the platform interlock (if present).
- ▶ Swivel the platform up to the roller at the support tube.
- ▶ Press the pushbutton **(28)** and hold it in this position until the platform is folded away under the vehicle.  
*The platform lifts and is moved under the vehicle.*

**B M<sup>h</sup>** Operation Using One-hand Control**54** Toggle switch**DANGER!****Risk of accidents and injury!**

If the instructions in chapter “General Operation” are not observed during operation of the tail lift, personal injuries and material damage can occur.

- ▶ Before operating the tail lift, read chapter “General Operation” from p. 24.

### Folding Out the Platform



- ▶ Loosen the platform interlock (if present).
- ▶ Press the toggle switch **(54)** downward and hold it in this position until the torsion frame touches the ground.
- ▶ Protect your hands with gloves.
- ▶ Pull the handle with both hands to swivel the platform to the horizontal position.
- ▶ Pull the handle with both hands to unfold the folding part of the platform.

### Lowering the Platform



- ▶ Press the toggle switch **(54)** downward and hold it in this position until the platform reaches the ground tilt while lowering.

### Lifting the Platform



- ▶ Press the toggle switch **(54)** upward and hold it in this position until the platform reaches the loading position while lifting.

### Folding In the Platform



- ▶ Make sure that the platform is in horizontal position touching the ground.
- ▶ Protect your hands with gloves.
- ▶ Fold the platform tip onto the platform.
- ▶ Close the platform interlock (if present).
- ▶ Swivel the platform up to the roller at the support tube.

## V Operation Using two Hand Cable Controls with three Pushbuttons, each

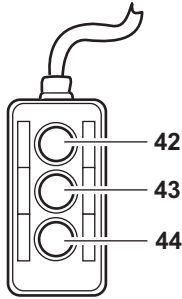

### Hand Cable Control 1

- 42 Pushbutton: lift platform
- 43+42 Pushbutton: close platform
- 44 Pushbutton: lower platform
- 43+44 Pushbutton: open platform

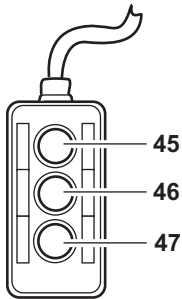

### Hand Cable Control 2

- 45 Pushbutton: lift platform
- 46+45 Pushbutton: fold in link bridge
- 47 Pushbutton: lower platform
- 46+47 Pushbutton: fold out link bridge

## DANGER!



### Risk of accidents and injury!

If the instructions in chapter "General Operation" are not observed during operation of the column lift, personal injuries and material damage can occur.

- ▶ Before operating the column lift, read chapter "General Operation" from p. 24.

**DANGER!****Crushing hazard due to wrong operator position!**

If the operator does not stand in the correct position when moving the platform via the hand cable control, personal injury and material damage may occur.

- ▶ Make sure to stand in the correct position (see the picture below) when operating the platform with the hand cable control. Do not stand in another position.
- ▶ When operating the platform with the hand cable control while standing inside the vehicle, always keep a minimum distance of 250 mm from the sill.
- ▶ Do not stand in the area near the platform edge where you risk to crush your feet when the platform approaches the vehicle sill.
- ▶ Exclusively stand in the platform area marked with the foot symbols in the illustration when moving the platform.
- ▶ When standing on the ground for operating the platform, keep a minimum distance of 1 m from all platform rims.
- ▶ Make sure that you can see the entire working area and that no other person stays on or near the platform.

**Operator positions  
for hand cable  
control**

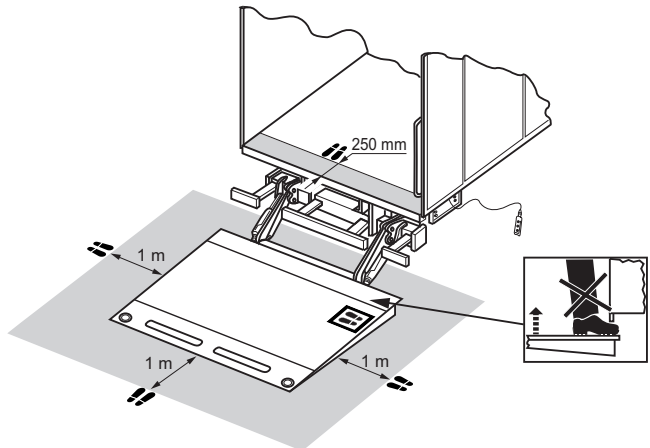

**DANGER!****Risk of accidents and injury!**

Failure to observe the instructions below when operating the column lift may result in persons or objects falling off the platform, causing serious injuries or damage to property.

- ▶ Prior to lifting or lowering the platform always set upright the two safety railings.
- ▶ When loading rolling containers without brakes always set the link bridge upright to use it as a roll stop.
- ▶ Use the roll stop towards the vehicle rear side to prevent containers of this type from rolling off the platform and into the vehicle in an uncontrollable manner.
- ▶ When loading the platform, leave enough free space for the operator (minimum 50 x 60 cm).
- ▶ When operating the column lift from a position on the platform, exclusively use the hand cable control 2. As this hand cable control only allows you to "lift" and "lower" the platform or to "fold in" and "fold out" the link bridge, it is not possible to accidentally "open" or "close" the platform and, thus, tilt it.

**CAUTION!****Risk of injuries or damage to the vehicle!**

An insufficient load carrying capacity of the ground may result in damage to the vehicle or load.

- ▶ Make sure that the ground can carry the weight of both the vehicle tail and the load.
- ▶ When working with a loading ramp, make sure that the link bridge has sufficient contact with the ramp.

### Opening the Platform



- ▶ Press the pushbutton **(43)** on the hand cable control 1 and hold it in this position. Briefly after this press and hold the pushbutton **(44)** on the same hand cable control. Hold both pushbuttons in this position until the platform is horizontal.

#### Note:

When loading the platform, you can simply compensate for any height differences by using the “open” or “close” functions.

### Setting the Safety Railing Upright



- ▶ Grasp one of the safety railings lying on the platform and swivel it up.
- ▶ Secure the safety railing in its upright position. For this purpose, engage the lug of the fastener to the hook.
- ▶ Repeat these steps for the other safety railing.

### Lifting the Platform



- ▶ If required, open the top flap. This is necessary if you want to use the upper vehicle deck.
- ▶ Press either the pushbutton **(42)** on hand cable control 1 or the pushbutton **(45)** on hand cable control 2 and hold it in this position until the platform has reached the required height.

### Lowering the Platform



- ▶ Press either the pushbutton **(44)** on hand cable control 1 or the pushbutton **(47)** on hand cable control 2 and hold it in this position until the platform has reached the required height.

### Folding Out the Link Bridge



- ▶ Press the pushbutton **(46)** on the hand cable control 2 and hold it in this position. Briefly after this press and hold the pushbutton **(47)** on the same hand cable control. Hold both pushbuttons in this position until the link bridge has reached the required position.

### Folding In the Link Bridge



- ▶ Press the pushbutton **(46)** on the hand cable control 2 and hold it in this position. Briefly after this press and hold the pushbutton **(45)** on the same hand cable control. Hold both pushbuttons in this position until the link bridge has reached the required position.

### Putting Down the Safety Railings



- ▶ Open the fastener of the first safety railing and swivel down the railing until it lies on the platform.
- ▶ Repeat this procedure for the second safety railing.

### Closing the Platform



- ▶ Press the pushbutton **(43)** on the hand cable control 1 and hold it in this position. Briefly after this press and hold the pushbutton **(42)** on the same hand cable control. Hold both pushbuttons in this position until the platform is completely closed.



## ABCEFGKLM

### Optional Operating Method: Foot Control

Platform with 2 foot controls  
(standard control)

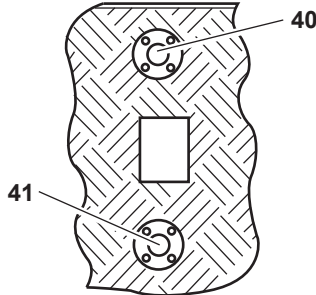

- 40 Foot control  
(at platform rim)
- 41 Foot control

Platform with 3 foot controls  
(control unit with basic board)

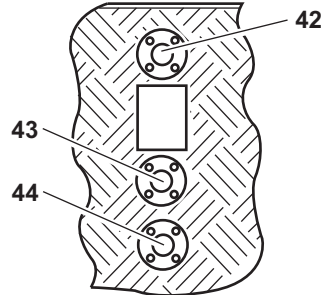

- 42 Additional foot control  
(at platform rim)
- 43 Foot control: lift
- 44 Foot control: lower

## DANGER!



### Risk of accidents and injury!

If the instructions in chapter “General Operation” not observed during operation of the tail lift, personal injuries and material damage can occur.

- ▶ Before operating the tail lift, read chapter “General Operation” from p. 24.

### Lowering the Platform

#### Platform with 2 Foot Controls



- ▶ Step on the foot control (**40**) and keep it in this position.
- ▶ After one second at the earliest and three seconds at the latest, step on the foot control (**41**) and keep it in this position.

*The platform is lowered and automatically adjusts to the ground.*

- Note:** If both foot controls are not actuated within three seconds, the foot controls are disabled for a short time. Wait a few seconds before you repeat the procedure.



### Platform with 3 Foot Controls

- ▶ Step on the foot control **(44)** and on the additional foot control **(42)**.

*The platform is lowered and automatically adjusts to the ground.*

### Lifting the Platform

#### Platform with 2 Foot Controls



- ▶ Step on the foot control **(41)** and keep it in this position.
- ▶ After one second at the earliest and three seconds at the latest, step on the foot control **(40)** and keep it in this position.

*Before the platform is lifted it tilts to the horizontal position.*

#### Note:

If both foot controls are not actuated within three seconds, the foot controls are disabled for a short time. Wait a few seconds before you repeat the procedure.

#### Platform with 3 Foot Controls



- ▶ Step on the foot control **(43)** and on the additional foot control **(42)**.

*Before the platform is lifted it tilts to the horizontal position.*

A B C E F G K L M

## Optional Operating Method: Hand Cable Control with two Pushbuttons

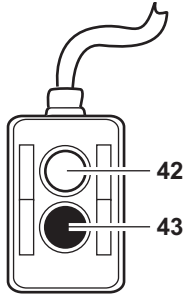

42 Pushbutton: lift

43 Pushbutton: lower

### DANGER!



#### Risk of accidents and injury!

If the instructions in chapter "General Information" are not observed during operation of the tail lift, personal injuries and material damage can occur.

- ▶ Before operating the tail lift, read chapter "General Operation" from p. 24.

**DANGER!****Crushing hazard due to wrong operator position!**

If the operator does not stand in the correct position when moving the platform via the hand cable control, personal injury and material damage may occur .

- ▶ Make sure to stand in the correct position (see the picture below) when operating the platform with the hand cable control. Do not stand in another position.
- ▶ When operating the platform with the hand cable control while standing inside the vehicle, always keep a minimum distance of 250 mm from the sill.
- ▶ Do not stand in the squeezing area where the platform approaches the vehicle body.
- ▶ Exclusively stand in the platform area marked with the foot symbols in the illustration when moving the platform.
- ▶ When standing on the ground for operating the platform, keep a minimum distance of 1 m from all platform rims.
- ▶ Make sure that you can see the entire working area and that no other person stays on or near the platform.

**Operator positions  
for hand cable  
control**

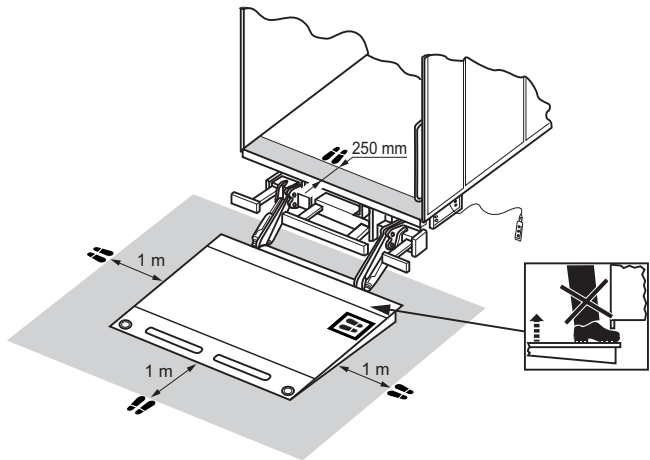

### Lowering the Platform



- ▶ Press the pushbutton **(43)** and keep it pressed until the platform is adjusted flush to the ground.

*After the platform has touched the ground it tilts and adjusts to the ground.*

### Lifting the Platform



- ▶ Press the pushbutton **(42)** and keep it pressed until the platform has reached the loading position.

*Before the platform is lifted it tilts to the horizontal position.*

## ACEFGKLM

### Optional Operating Method: Hand Cable Control with three Pushbuttons

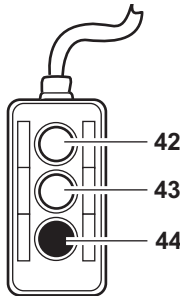

- 42** Pushbutton: lift
- 43** Pushbutton: tilt
- 44** Pushbutton: lower

## DANGER!



### Risk of accidents and injury!

If the instructions in chapter "General Information" are not observed during operation of the tail lift, personal injuries and material damage can occur.

- ▶ Before operating the tail lift, read chapter "General Operation" from p. 24.

**DANGER!****Crushing hazard due to wrong operator position!**

If the operator does not stand in the correct position when moving the platform via the hand cable control, personal injury and material damage may occur .

- ▶ Make sure to stand in the correct position (see the picture below) when operating the platform with the hand cable control. Do not stand in another position.
- ▶ When operating the platform with the hand cable control while standing inside the vehicle, always keep a minimum distance of 250 mm from the sill.
- ▶ Do not stand in the squeezing area where the platform approaches the vehicle body.
- ▶ Exclusively stand in the platform area marked with the foot symbols in the illustration when moving the platform.
- ▶ When standing on the ground for operating the platform, keep a minimum distance of 1 m from all platform rims.
- ▶ Make sure that you can see the entire working area and that no other person stays on or near the platform.

**Operator positions  
for hand cable  
control**

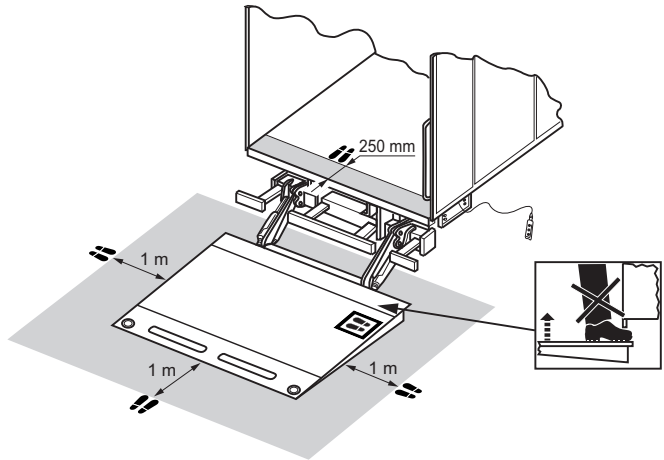

### Lowering the Platform



- ▶ Press the pushbutton **(44)** and keep it pressed until the platform is adjusted flush to the ground.

*After the platform has touched the ground it tilts and adjusts to the ground.*

### Lifting the Platform



- ▶ Press the pushbutton **(42)** and keep it pressed until the platform has reached the loading position.

*Before the platform is lifted it tilts to the horizontal position.*

### Setting the Platform to its Horizontal Position

- ▶ To adjust a steeper tilt of the platform, press both pushbuttons **(42)** and **(43)** simultaneously.
- ▶ To adjust a flatter tilt or to adjust the platform flush to the ground, press both pushbuttons **(43)** and **(44)** simultaneously.

## A Optional Operating Method: Hand Cable Control with four Pushbuttons for MBB C 750 SX

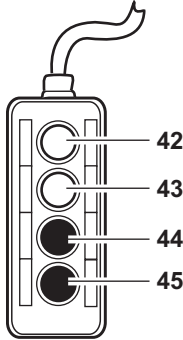

- 42 Pushbutton: lift
- 43 Pushbutton: lower
- 44 Pushbutton: Lift scissors
- 45 Pushbutton: Lower scissors

### DANGER!



#### Risk of accidents and injury!

If the instructions in chapter "General Information" are not observed during operation of the tail lift, personal injuries and material damage can occur.

- ▶ Before operating the tail lift, read chapter "General Operation" from p. 24.

**DANGER!****Crushing hazard due to wrong operator position!**

If the operator does not stand in the correct position when moving the platform via the hand cable control, personal injury and material damage may occur .

- ▶ Make sure to stand in the correct position (see the picture below) when operating the platform with the hand cable control. Do not stand in another position.
- ▶ When operating the platform with the hand cable control while standing inside the vehicle, always keep a minimum distance of 250 mm from the sill.
- ▶ Do not stand in the squeezing area where the platform approaches the vehicle body.
- ▶ Exclusively stand in the platform area marked with the foot symbols in the illustration when moving the platform.
- ▶ When standing on the ground for operating the platform, keep a minimum distance of 1 m from all platform rims.
- ▶ Make sure that you can see the entire working area and that no other person stays on or near the platform.

**Operator positions  
for hand cable  
control**

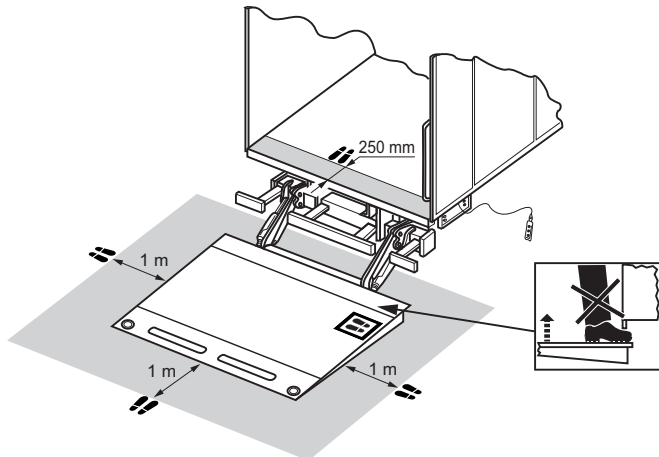

### Lowering the Platform



- ▶ Press the pushbutton **(43)** and keep it pressed until the platform is adjusted flush to the ground.

*After the platform has touched the ground it tilts and adjusts to the ground.*

### Lifting the Platform



- ▶ Press the pushbutton **(42)** and keep it pressed until the platform has reached the loading position.

*Before the platform is lifted it tilts to the horizontal position.*

### Lifting the scissors



- ▶ Press the pushbutton **(44)** and keep it pressed until the platform has reached the loading position.

### Lowering the scissors



- ▶ Press the pushbutton **(45)** and keep it pressed until the platform has reached the loading position.

A C F G K L

## Optional Operating Method: Wireless Remote Control Unit (Standard)

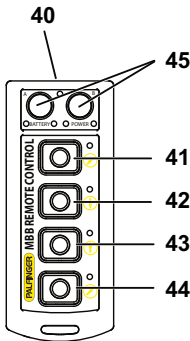

- 40** Slide switch: On/Off
- 41** Pushbutton: open
- 42** Pushbutton: lower
- 43** Pushbutton: lift
- 44** Pushbutton: close
- 45** Pushbutton: special function

### DANGER!



#### Risk of accidents and injury!

If the instructions in chapter "General Information" are not observed during operation of the tail lift, personal injuries and material damage can occur.

- ▶ Before operating the tail lift, read chapter "General Operation" from p. 24.

**Note:** A detailed description to the wireless remote control unit is part of the manual which is in the package of the wireless remote control unit.

#### Switching the Wireless Remote Control Unit On/Off

- ▶ In order to connect, slide the switch (**40**) upwards. The transmitter remains connected, until the switch (**40**) will have been slid downwards.

#### Lowering the Platform



- ▶ Press the pushbutton (**42**) and keep it pressed until the platform is adjusted flush to the ground.

*After the platform has touched the ground it tilts and adjusts to the ground.*

### Lifting the Platform



- ▶ Press the pushbutton **(43)** and keep it pressed until the platform has reached the loading position.

*Before the platform is lifted it tilts to the horizontal position.*

### Opening the Platform



- ▶ Loosen the platform interlock (if present).
- ▶ Press the pushbutton **(41)** and keep it pressed until the platform is completely open.

*If an optional load safety device is present, the platform is lowered a small amount and then unfolds to the horizontal operating position.*

### Closing the Platform



- ▶ Press the pushbutton **(44)** and keep it pressed until the platform is completely closed.

*If an optional load safety device is present, the platform closes approximately to 80° and is lowered a small amount. Subsequently it moves to the vertical transport position and is lifted into the load safety device.*

- ▶ Close the platform interlock (if present).

### Setting the Platform to its Horizontal Position

- ▶ In order to obtain a steeper platform tilt angle, press the pushbutton **(44)**.
- ▶ In order to obtain a flatter platform tilt angle or let the platform make contact with the ground, press the pushbutton **(41)**.

## A C E K L Special Operating Elements

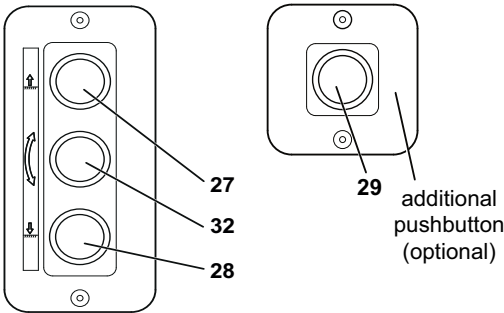

- 27 Pushbutton: lift/close
- 28 Pushbutton: lower/open
- 29 Pushbutton: additional pushbutton
- 32 Pushbutton: close/open

### DANGER!



#### Risk of accidents and injury!

If the instructions in chapter “General Operation” are not observed during operation of the tail lift, personal injuries and material damage can occur.

- ▶ Before operating the tail lift, read chapter “General Operation” from p. 24.

#### Opening the Platform



- ▶ Loosen the platform interlock (if present).
- ▶ Press the pushbuttons **(28)**, **(32)** and optionally **(29)** simultaneously and hold them in this position until the platform has reached the horizontal operating position.

#### Lowering the Platform



- ▶ Press the pushbuttons **(28)** and optionally **(29)** simultaneously and hold them in this position until the platform has made contact with the ground.

*After the platform has touched the ground it tilts and adjusts to the ground.*

### Lifting the Platform



- ▶ Press the pushbuttons **(27)** and optionally **(29)** simultaneously and hold them in this position until the platform has reached the vehicle loading floor height.

*The platform tilts to the horizontal or preset position before it is lifted.*

### Closing the Platform



- ▶ Press the pushbuttons **(27)**, **(32)** and optionally **(29)** simultaneously and hold them in this position until the platform is closed.

## F G Special Operating Elements

- 27 Pushbutton: lift/close
- 28 Pushbutton: lower/open
- 32 Pushbutton: close/open
- 29 Pushbutton: additional pushbutton
- 30 Pushbutton: extend
- 31 Pushbutton: retract

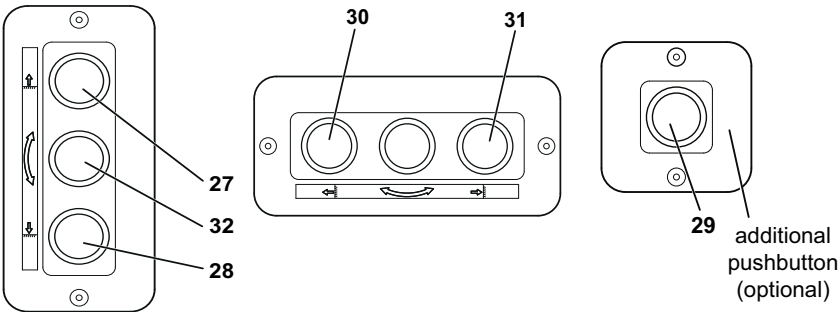

### DANGER!



#### Risk of accidents and injury!

If the instructions in chapter “General Operation” are not observed during operation of the tail lift, personal injuries and material damage can occur.

- ▶ Before operating the tail lift, read chapter “General Operation” from p. 24.

#### Lowering the Platform



- ▶ Press the pushbuttons (28) and optionally (29) simultaneously and hold them in this position until the platform has made contact with the ground.

*After the platform has touched the ground it tilts and adjusts to the ground.*

#### Lifting the Platform



- ▶ Press the pushbuttons (27) and optionally (29) simultaneously and hold them in this position until the platform has reached the vehicle loading floor height.

*The platform tilts to the horizontal or preset position before it is lifted.*

### Setting the Platform to its Horizontal Position

- ▶ To adjust a steeper tilt of the platform, press both pushbuttons **(27)**, **(32)** and optionally **(29)** simultaneously and hold them in this position until the platform has reached the required tilt angle.
- ▶ To adjust a flatter tilt of the platform, press both pushbuttons **(28)**, **(32)** and optionally **(29)** simultaneously and hold them in this position until the platform has reached the required tilt angle.

### Extending and Folding Out the Platform

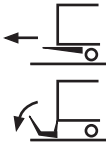

- ▶ Loosen the platform interlock (if present).
- ▶ Press the pushbuttons **(28)** and optionally **(29)** simultaneously and hold them in this position until the platform has completely lowered.  
*The platform is lowered so that it can be extended without obstruction.*
- ▶ Press the pushbutton **(30)** and hold it in this position until the platform is completely extended.
- ▶ Press the pushbuttons **(28)** and optionally **(29)** simultaneously and hold them in this position until the folded platform has made contact with the ground.
- ▶ Protect your hands with gloves.
- ▶ Pull the handle with both hands to unfold the folding part of the platform.

### Folding In and Retracting the Platform

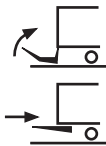

- ▶ Protect your hands with gloves.
- ▶ Pull the handle with both hands to fold back the folding part of the platform.
- ▶ Close the platform interlock (if present).
- ▶ Press the pushbuttons **(27)** and optionally **(29)** simultaneously and hold them in this position until the platform has reached the retraction height.
- ▶ Press the pushbutton **(31)** and hold it in this position until the platform is completely retracted. Make sure that the platform can be retracted without obstruction.
- ▶ Press the pushbuttons **(27)** and optionally **(29)** simultaneously and hold them in this position until the platform has reached the vibration safeguard.

## A C E K L Special Operating Elements

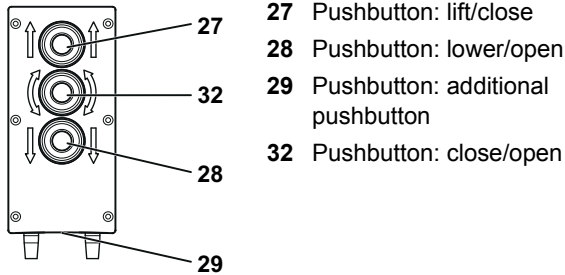

- 27 Pushbutton: lift/close
- 28 Pushbutton: lower/open
- 29 Pushbutton: additional pushbutton
- 32 Pushbutton: close/open

### DANGER!



#### Risk of accidents and injury!

If the instructions in chapter “General Operation” are not observed during operation of the tail lift, personal injuries and material damage can occur.

- ▶ Before operating the tail lift, read chapter “General Operation” from p. 24.

#### Opening the Platform



- ▶ Loosen the platform interlock (if present).
- ▶ Press the pushbuttons **(28)**, **(32)** and **(29)** simultaneously and hold them in this position until the platform has reached the horizontal operating position.

#### Lowering the Platform



- ▶ Press the pushbuttons **(28)** and **(29)** simultaneously and hold them in this position until the platform has made contact with the ground.

*After the platform has touched the ground it tilts and adjusts to the ground.*

#### Lifting the Platform



- ▶ Press the pushbuttons **(27)** and **(29)** simultaneously and hold them in this position until the platform has reached the vehicle loading floor height.

*The platform tilts to the horizontal or preset position before it is lifted.*

#### Closing the Platform



- ▶ Press the pushbuttons **(27)**, **(32)** and **(29)** simultaneously and hold them in this position until the platform is closed.

All Models

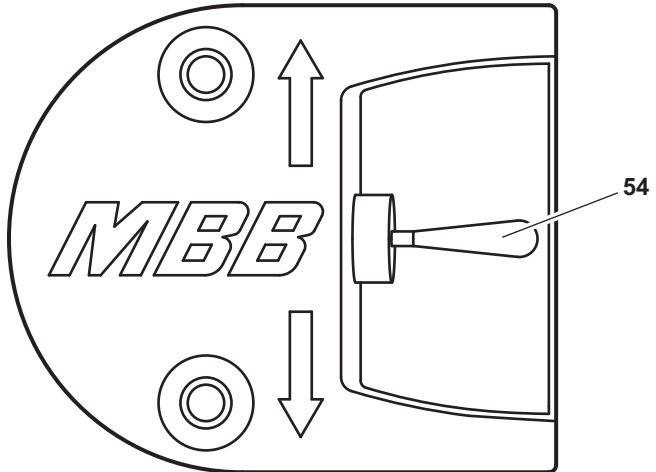
**Special Operating Elements for Hydraulic Stabilizer Feet****54** Toggle switch**DANGER!****Risk of accidents and injury!**

If the instructions in chapter “General Operation” are not observed during operation of the tail lift, personal injuries and material damage can occur.

- ▶ Before operating the tail lift, read chapter “General Operation” from p. 24.

**Extending the Hydraulic Stabilizer Feet**

- ▶ Push down the toggle switch (**54**) until the stabilizer feet are extended almost to the ground.

**Retracting the Hydraulic Stabilizer Feet**

- ▶ Push up the toggle switch (**54**) until the stabilizer feet are completely retracted.

## A Programming a Key Code

- ▶ You can switch on the tail lift by a key code. The factory setting is:

Key (Combination) to be Pressed		
Lift	Close	Lift
3 x	3 x	3 x

To change this key code:

- ▶ Open the platform.
- ▶ Bring down the platform until it is adjusted flush to the ground.
- ▶ Open the sealing cap of the support tube (on the right, as seen in direction of travel) or open the cover of the hydraulic unit.
- ▶ Disconnect plug J 30.
- ▶ Switch off the electrical equipment.
- ▶ Connect the contacts J 30/5, 6, 14, 3 with contact 4 (service plug).
- ▶ Switch on the electrical equipment.

*The tail lift is now in programming mode.*

- ▶ Disconnect the service plug and connect plug J 30 at the lateral operating element.
- ▶ Enter the desired code at the lateral operating element as follows:

Key (Combination) to be Pressed		
Lift	Close	Lift
x-times	x-times	x-times

*Each key actuation switches on the warning lights.*

*If your entry has been correct, the programming mode is automatically left. You can continue to operate your tail lift as usual.*

*If your entry was faulty, the warning lights briefly flash 5 times. You have to enter the code again.*

## Clearing the Service Counter (Maintenance Counter)

After 5000 cycles (lifts) the tail lift should be serviced. The control box will flash for 2 seconds with high frequency after switch-on to indicate that this limit value is reached. Proceed as described below to clear the service counter after this.

- ▶ Close the platform, but leave the control box switched on.
- ▶ Disconnect plug J 11.
- ▶ Disconnect plug J 30.
- ▶ Connect the service plug.
- ▶ Connect plug J 11.

*The service counter is cleared.*

- ▶ Disconnect the service plug.
- ▶ Connect plug J 30.
- ▶ Disconnect plug J 11 and connect it again.

*This switches the tail lift back into operating mode.*

**Note:** You can also reset the service counter by using the diagnostic software.

## Troubleshooting

This function is only available for special program versions. For more information please contact our customer service. Proceed as follows to troubleshoot the tail lift:

- ▶ Switch on the control box.
- ▶ Open the platform so that it is in horizontal position.
- ▶ Disconnect plug J 11.
- ▶ Disconnect plug J 30.
- ▶ Connect the service plug.
- ▶ Connect plug J 11.
- ▶ Disconnect the service plug.
- ▶ Connect plug J 30.

*Every connected input is now indicated by continuous warning lights.*

*If your tail lift is not equipped with Warnfix, you have to connect a test lamp to PIN 7 of plug J3.*

- ▶ Disconnect plug J 11 and connect it again.

*This switches the tail lift back into operating mode.*

**Note:** You can also troubleshoot your tail lift by using the diagnostic software.

## Error Recognition by Using the 7-Segment Display

This function is only available with MBB Control.

<b>Status indication</b> (7 segments, static, System LED flashing green (2 Hz))	
Status	Description
Status 0 =>	System switched on and all right, control box switched off
Status 1 =>	System switched on and all right, control box switched on

<b>Error indication</b> (7 segments, flashing (0.5 Hz), System LED flashing red (2 Hz))		
Status	Description	Action for error reset
Error 2 =>	Undervoltage	Switch off/on control box
Error 3 =>	On lift arms switch (B13): On signal although tail lift is closed -> Short-circuit on B13 With MBB Control Eco -> lift arms switch B16 defective	Automatic error reset as soon as correct values are reached
Error 4 =>	Lift arms tilt sensor (B15): Faulty sensor signal	
Error 5 =>	Head tilt sensor (B15): Faulty sensor signal	
Error 6 =>	Warnfix: short-circuit recognized	Switch control box off/on or close tail lift
Error 7 =>	Box body light/control box LED: short-circuit recognized	
Error 8 =>	General short-circuit error of external system	Switch control box off/on or de-energize PC board

<b>Valve coil monitoring</b> (not available for all models)		
Status	Description	Action for error reset
Error 9 =>	While lifting the platform, the "motor relay coil resistance" error was detected.	Automatic error reset as soon as correct values are reached
Error "a" =>	Not used or reserved	
Error "b" =>	While opening the platform, the "valve coil resistance open S3_S4" or "motor relay resistance" error has been detected	
Error "c" =>	While closing the platform, the "motor relay resistance" or "S5" error was detected.	Automatic error reset as soon as correct values are reached
Error "d" =>	While lowering the platform, the "valve coil resistance lower_S1_S2" error has been detected	

<b>Service functions</b> <i>(not available for all models)</i>		
<b>Status</b>	<b>Description</b>	<b>Action for disabling</b>
<b>Error "A" =&gt;</b>	<b>No voltage at J1/2 -&gt; Check fuse.</b>	<b>Automatic error reset as soon as voltage is present at J1/2.</b>
<b>Error "E" =&gt;</b>	<b>Emergency program, sensor system being bridged. Re-enable by pressing and holding "Open" and "Lower" push-buttons for more than 10 seconds.</b>	<b>Switch off/on control box</b>
<b>Error "P" =&gt;</b>	<b>Error diagnosis of all inputs is active. Warnfix is activated upon each push-button actuation.</b>	<b>Remove service plug</b>

## Service and Maintenance

### DANGER!



#### Risk of accidents and injury!

If the instructions in chapter “General Operation” are not observed during maintenance or service of the tail lift or column lift, personal injuries and material damage can occur.

- ▶ Before working on the tail lift or column lift, read chapter “General Operation” from p. 24.

### A B C F G K L M

### Maintenance Intervals

Activity	Daily	Depending on Usage	Monthly	Quarterly	Semi-annually	Annually
Checking the function and presence of the safety and warning devices	X					
Cleaning the tail lift		X				
Checking the battery		X				
Checking the carbon brushes at the electric motor		X				
Checking the oil level and refilling oil, if necessary			X			
Checking the bolts and nuts for tight seat			X			
Checking the screw fittings and pipes of the hydraulic system						X
Lubricating the low-maintenance bearings		X				
Changing the oil						X
Applying wax spray to the PC board		X				
Checking if the marks on the platform for the payload center of gravity and the operator position (when operating the tail lift or column lift with the hand cable control) are readable and in a good condition. Refreshing the marks using an abrasion-resistant paint, if required.		X				

Activity	Daily	Depending on Usage	Monthly	Quarterly	Semi-annually	Annually
For retractable tail lifts: Cleaning and lubricating guide rails		X				
If unused for more than 3 months: Moving (open, lower, lift, close) tail lift several times				X		

## E Maintenance Intervals

Activity	Daily	Depending on Usage	Monthly	Quarterly	Semi-annually	Annually
Checking the function and presence of the safety and warning devices	X					
Cleaning the tail lift		X				
Checking the battery		X				
Checking the bolts and nuts for tight seat			X			
Lubricating the low-maintenance bearings		X				
Checking the bellows			X			
Applying wax spray to the PC board		X				
Checking if the marks on the platform for the payload center of gravity and the operator position (when operating the tail lift or column lift with the hand cable control) are readable and in a good condition, refreshing the marks using an abrasion-resistant paint, if required		X				
If unused for more than 3 months: Moving (open, lower, lift, close) tail lift several times				X		

Depending on the frequency of use and external influences, the maintenance intervals can be shorter.

## V Maintenance Intervals

### DANGER!



#### Risk of accidents and injury!

When executing any maintenance or service work under the platform of the column lift, there is a risk of personal injury or property damage if the platform is not secured properly.

- ▶ Always secure the platform slide or platform against moving downwards.

Activity	Daily	Depending on Usage	Monthly	Quarterly	Semi-annually	Annually
Checking the function and presence of the safety and warning devices	X					
Cleaning the column lift		X				
Cleaning and lubricating the sliding surface of the slider in the frame					X	
Checking the battery		X				
Checking the carbon brushes at the electric motor		X				
Checking the oil level and refilling oil, if necessary			X			
Checking the bolts and nuts for tight seat			X			
Checking the screw fittings and pipes of the hydraulic system						X
Lubricating the low-maintenance bearings		X				
Changing the oil						X
Applying wax spray to the PC board		X				
Checking the mark for the payload center of gravity for good readability; refreshing mark with abrasion-resistant paint if required		X				
If unused for more than 3 months: Moving (open, lower, lift, close) tail lift several times				X		

## All Models Maintenance Before Starting

### Checking the Safety and Warning Devices

The safety devices of the tail lifts comply with the respective current version of the valid regulations.

- ▶ Before starting to drive, check whether all safety and warning devices are operational.
- ▶ Renew any damaged and non-operational safety and warning devices.

Depending on the model, the safety and warning devices comprise:

- non-slip platform surface
- roll-off protection on the platform (optional)
- holding grip for the accompanying operator (not in scope of delivery of the tail lift)
- warning flashers on the platform
- warning flags behind the platform
- platform interlock at the platform (optional)
- two-feet control for “lift” and “lower” on the platform
- key control at lateral operating element for trailers or semi-trailers
- control box with ON/OFF switch in lockable driver's cab
- optical signal at control box in driver's cab for tail lift “ON” and/or platform open
- stop valves on lift and tilt cylinders to prevent line break (except model E)
- flow valves for limiting the lowering and opening speed (except model E)

## Maintenance Depending on Usage Frequency

### All Models

#### Cleaning the Tail Lift

#### CAUTION!



#### Damage to paint!

If you clean the tail lift using a pressure washer, damage to the paint may occur up to six weeks after painting.

- ▶ Cleaning the tail lift with a pressure washer should not be done earlier than six weeks after painting.

The following parts of the tail lift may not be cleaned with a pressure washer:

- piston rods and cylinder seals
- lateral operating element
- solenoid valves (except model E)
- foot control
- warning lights and warning flags
- Bellows

### All Models

#### Checking the Battery

- ▶ Service the battery in the usual way.

### A B C F G K L M V

#### Checking the Carbon Brushes at the Electric Motor

#### CAUTION!



#### Risk of burns by overheating electric motor!

Worn out and contaminated carbon brushes can result in increased current consumption. This can cause the electric motor to overheat.

- ▶ Occasionally clean the carbon brushes.
- ▶ Contact a service engineer or a contractor repair shop to have worn out or contaminated carbon brushes replaced.

- ▶ Occasionally check the carbon brushes of the electric motor in the hydraulic unit and clean them to remove the carbon dust.

**All Models****Applying Wax Spray to the PC Board**

To protect the contacts against corrosion.

- ▶ Depending on the weather conditions and especially after exposure to salt water spray, apply wax spray to the PC board and the connector plugs.

**Greasing and Lubricating**

- ▶ Grease the conical lubricating head as required and after each cleaning with a pressure washer.

**Checking/Refreshing Platform Marks**

The marks on the platform must always be in a good condition and clearly visible. They indicate the payload center of gravity and the operator position on the platform when operating the tail lift by using the hand cable control.

- ▶ Check the marks for good visibility and refresh them if required with abrasion-resistant paint.

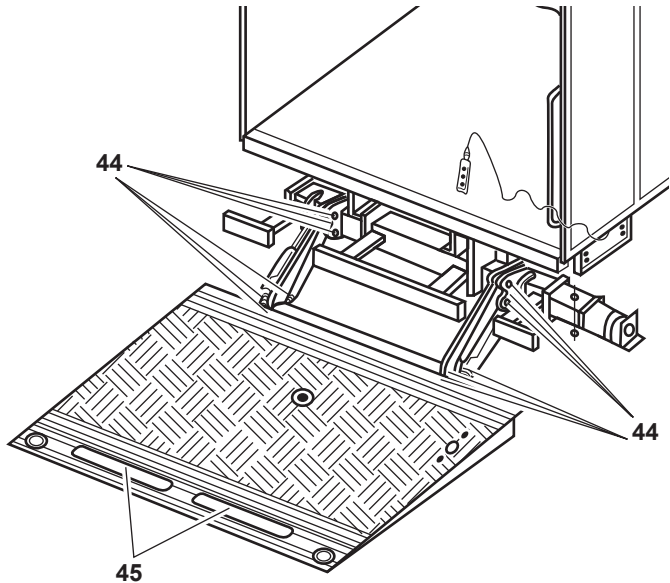
**A B C E** Standard Models (Upright Platform)

**44** Conical lubricating heads (grease nipples)

**45** Roll-off protection bearings

To grease and lubricate:

- ▶ Clean the conical lubricating heads.
- ▶ Use a grease gun to press grease into the conical lubricating heads (**44**) until the bearing is filled (see chapter “Lubricants and Operating Media” from p. 178).
- ▶ Lubricate the bearings of the roll-off protection (**45**) (see chapter “Lubricants and Operating Media” from p. 178).

## FG Retractable Models

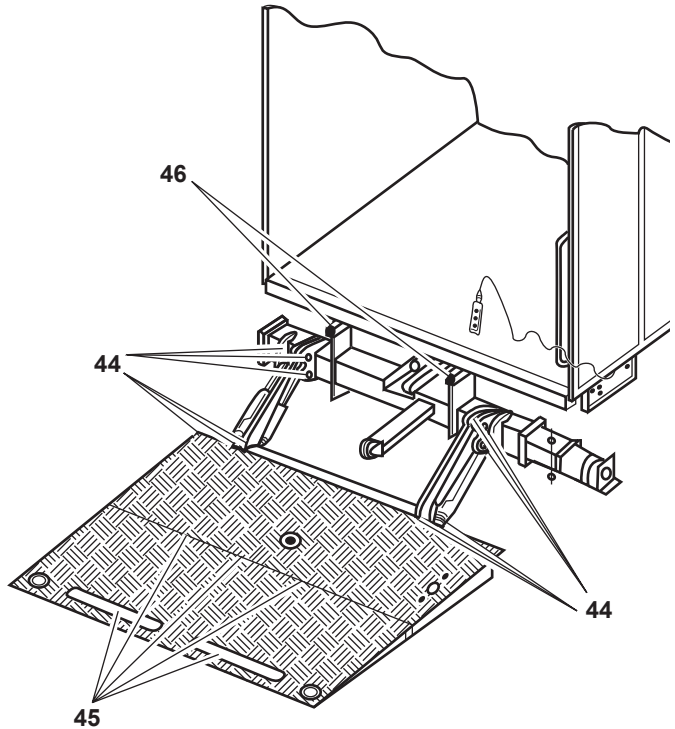

- 44** Conical lubricating head
- 45** Roll-off protection bearings and joint of folding platform
- 46** Sliding consoles in the guide rails (nozzle lubrication)

To grease and lubricate:

- ▶ Clean the conical lubricating heads.
- ▶ Use a grease gun to press grease into the conical lubricating heads (**44**) until the bearing is filled (see chapter “Lubricants and Operating Media” from p. 178).
- ▶ Lubricate the bearings of the roll stop and the joint in the platform (**45**).
- ▶ Lubricate the sliding consoles in the guide rails (**46**) (see chapter “Lubricants and Operating Media” from p. 178).

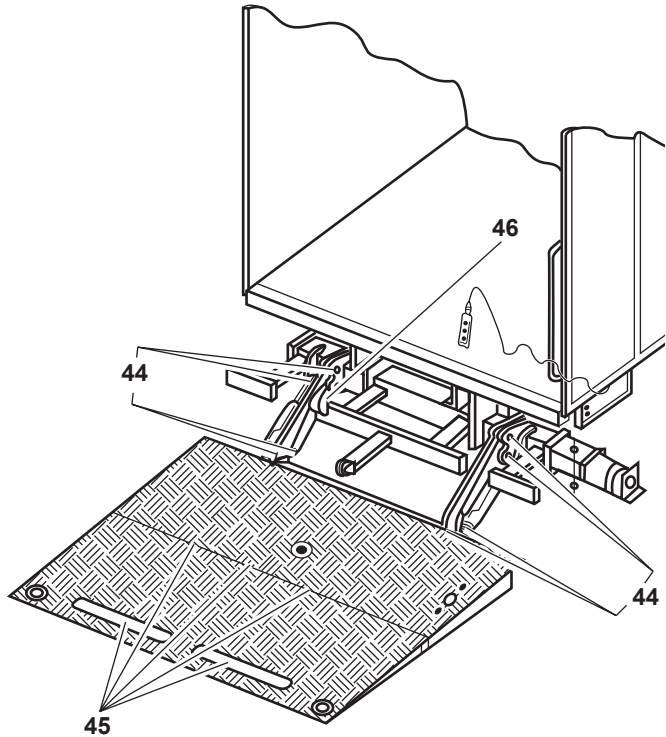
**K L M** Foldable Models

- 44** Conical lubricating head  
**45** Roll-off protection bearings and joint of folding platform  
**46** Bearings at the guide rails

To grease and lubricate:

- ▶ Clean the conical lubricating heads (**44**).
- ▶ Use a grease gun to press grease into the conical lubricating heads (**44**) until the bearing is filled (see chapter “Lubricants and Operating Media” from p. 178).
- ▶ Lubricate the bearings of the roll stop and the joint in the platform (**45**).
- ▶ Lubricate the sliding consoles in the guide rails (**46**) (see chapter “Lubricants and Operating Media” from p. 178).

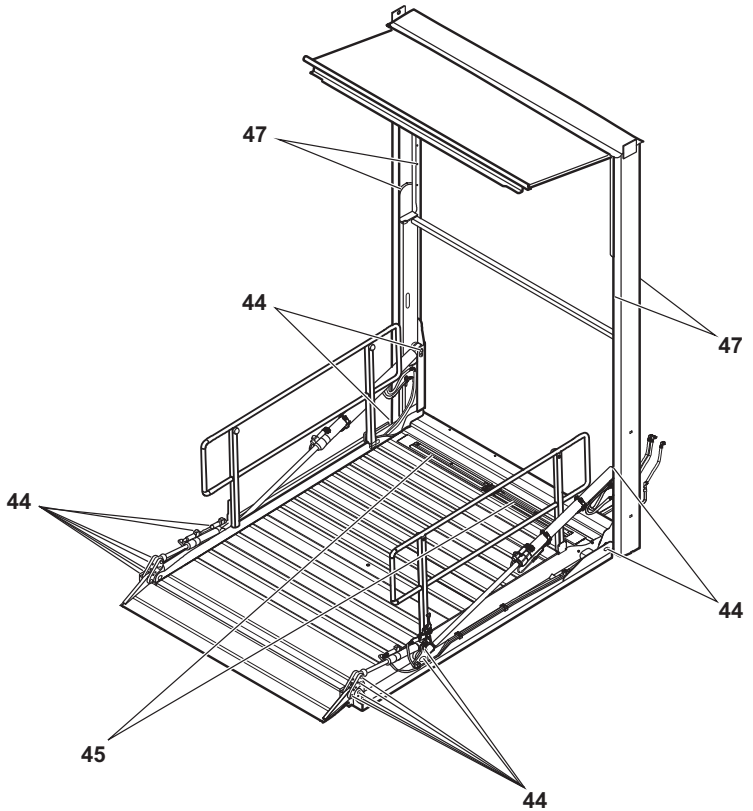
**V Column Lifts**

- 44** Conical lubricating head
- 45** Roll-off protection bearings
- 47** Sliding surface of the slider

To grease and lubricate:

- ▶ Clean the conical lubricating heads (**44**).
- ▶ Use a grease gun to press grease into the conical lubricating heads (**44**) until the bearing is filled (see chapter "Lubricants and Operating Media" from p. 178).
- ▶ Lubricate the bearings of the roll-off protection (**45**) (see chapter "Lubricants and Operating Media" from p. 178).
- ▶ Clean all sliding surfaces (**47**) of the slider in the guide frame and lubricate them evenly with heavy duty grease.

## Monthly Maintenance

### Checking the Oil Level

#### A B C Standard Tail Lifts

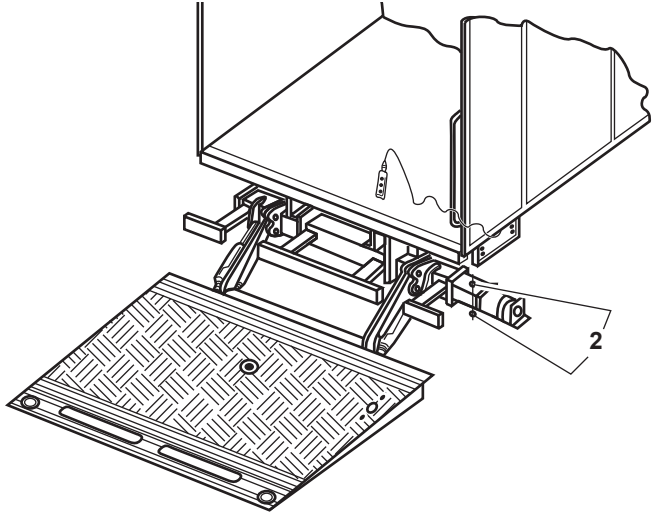

#### F G Retractable Models

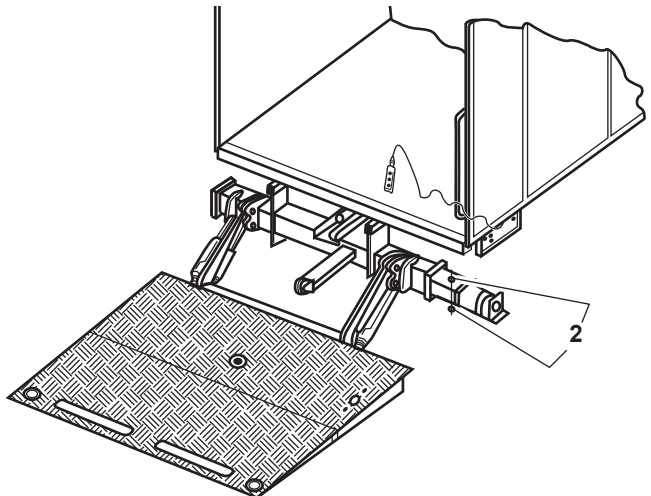

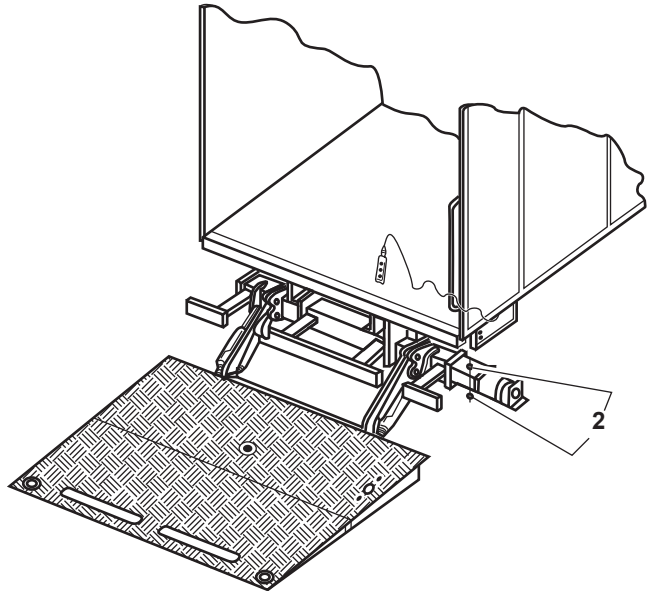
**K L M** Foldable Models**2** Hydraulic unit on support tube

**Slide-in Unit:** To check the oil level:

- ▶ Lower the tail lift so that the platform touches the ground.
- ▶ If required, retract all stabilizer feet.
- ▶ Open the right cover of the support tube.
- ▶ Loosen the fastening screw of the hydraulic unit at the support tube **(2)**.
- ▶ Pull out the hydraulic unit until the check mark at the oil reservoir is visible.
- ▶ Using the indicator at the oil reservoir or the dip stick, check whether the indication is within the prescribed marked range.
- ▶ If required, refill oil up to level mark.
- ▶ Re-insert the hydraulic unit in to the support tube and fasten it with the screw **(2)**.
- ▶ Close the cover of the support tube.

**Box-type or reversible unit:**

To check the oil level:

- ▶ Lower the tail lift so that the platform touches the ground.
- ▶ If required, retract all stabilizer feet.
- ▶ Remove the cover from the unit.
- ▶ Using the indicator at the oil reservoir or the dip stick, check whether the indication is within the prescribed marked range.
- ▶ If required, refill oil up to level mark.
- ▶ Re-install the cover of the unit.

**All Models****Checking the Bolts and Nuts for Tight Seat**

- ▶ Check whether all bolts and nuts are seated tightly.
- ▶ Especially observe all bearing pins and associated bolts and all fastening elements of the auxiliary frame and the tail lift mounting!
- ▶ Retighten any loose bolts and nut.

**ABCFGKLMV****Checking the Screw Fittings and Pipes of the Hydraulic System**

- ▶ Check all screw fittings and pipes of the hydraulic system. Make sure that the screws are tight and the hydraulic lines undamaged.
- ▶ Retighten any loose screws.
- ▶ Replace damaged hydraulic hoses immediately.
- ▶ Replace all hydraulic hoses after three years at the latest. The manufacture date is stamped on the fittings.

**All Models****Checking the Bellows**

- ▶ Make sure that the two bellows are in a good condition and undamaged and that they are tightly fit to the piston rod and cylinder.
- ▶ Replace damaged bellows immediately.

## Quarterly or Semi-annual Maintenance

### All Models

#### Lubrication of the Low-maintenance Bearings

- ▶ Clean the low-maintenance bearings.
- ▶ Grease the low-maintenance bearings with lubricant grease.

**Note:** If you use the tail lift quite frequently, the low-maintenance bearings must be greased more frequently than once a year.

#### Moving the Tail Lift

After a standstill of more than 3 months you have to move the tail lift several times.

- ▶ Open, lift, lower and close the tail lift using the corresponding operating element.
- ▶ Repeat this procedure approximately 5 times.

## Annual Maintenance

### A B C F G K L

#### Changing the Hydraulic Oil

#### CAUTION!



#### Risk of injury or material damage through waste oil!

If you do not change the oil in the hydraulic unit once a year, condensation water could accumulate, especially at temperatures below the freezing point. This disturbs the function of the tail lift. Persons could be injured and material could be damaged.

- ▶ Change the hydraulic oil once every year.
- ▶ Preferably change the oil shortly before the start of the winter season.

Slide-in Unit:

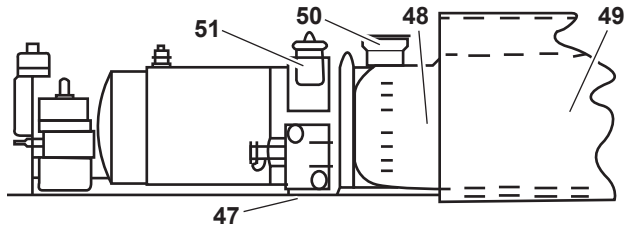

Box-type Unit:

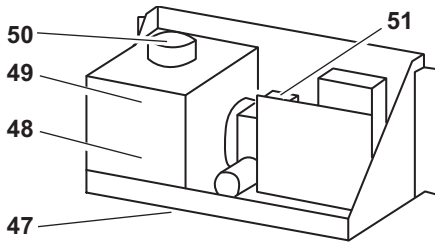

Reversible Unit

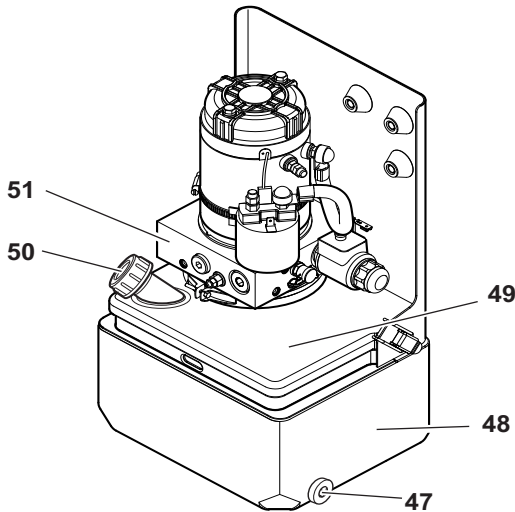

- 47 Oil drain plug
- 48 Hydraulic oil reservoir
- 49 Suction filter in the oil reservoir
- 50 Breather filter
- 51 Valve block

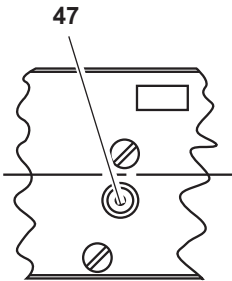

To change the hydraulic oil:

- ▶ Lower the tail lift so that the platform touches the ground (see chapter “Operating Elements” from p. 38).
- ▶ **For the slide-in unit:**  
Draw out the hydraulic unit so that the valve block (51) is positioned outside the block (see chapter “Checking the Oil Level” from p. 130).

**For the box-type or reversible unit:**

Remove the cover from the unit.

- ▶ Place a sufficiently large vessel under the oil drain plug (47).
- ▶ Loosen the oil drain plug (47) using a 6 mm hex socket wrench and drain the oil into the vessel.

If the hydraulic oil is extremely contaminated you must clean the hydraulic oil reservoir (48):

- ▶ Loosen the clamp between the hydraulic oil reservoir (48) and the valve block (51).
- ▶ Drain the oil.
- ▶ Pull off the hydraulic oil reservoir (48) from the unit and clean it outside the hydraulic unit.
- ▶ Also renew the suction filter in the oil reservoir (49) and the breather filter (50).
- ▶ Install the cleaned hydraulic oil reservoir into the unit and reinstall the oil drain plug (47).
- ▶ Fill oil according to the marking at the oil reservoir or dip stick.

**Note:** Exclusively use oils listed in the chapter “Lubricants and Operating Media” from p. 178.

- ▶ After filling the oil reservoir, run the equipment through two full working cycles.
- ▶ Check the oil level (see chapter “Checking the Oil Level” from p. 130) and refill or drain oil as required.
- ▶ **For the slide-in unit:**  
Push the hydraulic unit back into the support tube and fasten it.  
**For the box-type or reversible unit:**  
Re-install the cover of the unit.
- ▶ Dispose of the waste oil according the regulations.

## V Changing the Hydraulic Oil

### CAUTION!



#### Risk of injury or material damage through waste oil!

If you do not change the oil in the hydraulic unit once a year, condensation water could accumulate, especially at temperatures below the freezing point. This disturbs the function of the column lift. Persons could be injured and material could be damaged.

- ▶ Change the hydraulic oil once every year.
- ▶ Preferably change the oil shortly before the start of the winter season.

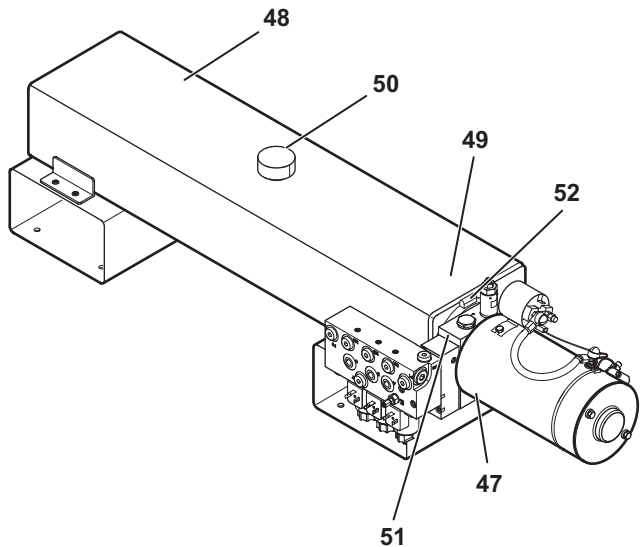

- 47 Oil drain plug
- 48 Hydraulic oil reservoir
- 49 Suction filter in the oil reservoir
- 50 Breather filter
- 51 Valve block
- 52 Clamp

To change the hydraulic oil:

- ▶ Close the platform with the link bridge folded in; as a result the entire hydraulic oil will flow into the hydraulic oil reservoir (see chapter "Operating Elements" from p. 38).
- ▶ Remove the breather filter (50).
- ▶ Suck out the hydraulic oil via the oil fill hole.

If the hydraulic oil is extremely contaminated you must clean the hydraulic oil reservoir (48):

- ▶ Remove the stop at the rear side of the oil reservoir.
- ▶ Loosen the clamp (52).
- ▶ Disconnect the hydraulic oil reservoir (48) from the valve block (51). Take care of the intake and outlet lines and the suction filter (49) in the hydraulic oil reservoir (48).
- ▶ Remove the hydraulic oil reservoir (48) from its guide and lift it off to clean it outside the vehicle.
- ▶ Re-insert and re-connect the hydraulic oil reservoir (48). Proceed as described above, but in reverse order.
- ▶ Fill oil according to the marking at the oil reservoir or dip stick. The fill level should be 2/3 of the dip stick.

**Note:**

Exclusively use oils listed in the chapter "Lubricants and Operating Media" from p. 178.

- ▶ After filling the oil reservoir, run the equipment through two full working cycles.
- ▶ Check the oil level (see chapter "Checking the Oil Level" from p. 130) and refill or drain oil as required.
- ▶ Push the hydraulic unit back into the support tube and fasten it.
- ▶ Dispose of the waste oil according the regulations.

**All Models****Protecting the Main Switch from Corrosion**

To protect the main switch with strip fuse against corrosion:

- ▶ Grease the main switch with contact grease.

**Checks**

With every tail lift a test data booklet is provided. According to this test data booklet the following checks must be performed by a specialist of your contractor repair shop:

- Check after installation, confirming the satisfactory commissioning in writing in the test data booklet.
- Periodic verification which must be performed at least once a year. The essential scope of checks is described in the test data booklet. The check must be confirmed in the test data booklet in writing.
- Extraordinary check after major repairs or structural changes. The check must be confirmed in the test data booklet in writing.

Structural changes are only allowed with the consent of the manufacturer. Any warranties shall become void if modifications at the tail lift are performed without our consent. The manufacturer shall not be held responsible for damages, accidents, etc. The same applies for the usage of third-party spare parts, if their use has not been explicitly approved.

## All Models Eliminating Faults

Faults may occur even in the best maintained and serviced tail lift.

The following description of possible faults will enable you to recognize faults quickly and eliminate them saving time and costs.

Principally, troubleshooting and the elimination of faults should be done in the contractor repair shops. In the list of repair shops you find the information how to find our contractor repair shops. If necessary, you can request the list free of charge from our sales offices or the factory.

For troubleshooting, preferably a test lamp can be used. Use the ground connector on the PC board for troubleshooting.

**Note:** If the tail lift can not be operated any more due to a defective sensor, it can be switched to an emergency operating mode. In the emergency operating mode the sensors are not called up. Proceed as described below to switch to the emergency operating mode:

- ▶ Press the pushbuttons "Open", "Lower" and if there is, the "Additional Key" for at least 10 seconds.

*In the 7-Segment Display an "E" appears. Now each tail lift movement has to be ordered manually. All the automatic processes are deactivated.*

Before troubleshooting, check the following:

- ▶ Make sure that the tail lift is switched on in the driver's cab.
- ▶ Check whether the battery main switch is switched on.
- ▶ Make sure that the main fuse for the power supply is intact.
- ▶ Check the two control-circuit fuses of the hydraulic unit or power unit for correct function.
- ▶ Check the control voltage fuse for 12 V systems at the vehicle battery for correct function.
- ▶ Make sure that the vehicle batteries function correctly and are charged.
- ▶ Verify that the ground cable on the hydraulic unit or power unit establishes a good connection between the tail lift and the vehicle.

- ▶ Make sure that the oil reservoir is sufficiently filled (except model E).
- ▶ Check that mechanical or electrical components, for example cables, are not damaged.

**WARNING!****Risk of burns in case of short-circuits!**

Serious burns can occur in case of a short-circuit of the high-power batteries.

- ▶ Before starting any work at the electric system, disconnect the battery main switch or disconnect the negative lead from the battery.

If more faults occur in the tail lifts you should not try to eliminate the faults yourself, but by contractor repair shops and with the aid of the following tables. The list of repair shops shows you the nearest repair shop and provides further contact information.

## **A C F G K L M Troubleshooting Tables**

<b>Before switching on</b>		
<b>Fault</b>	<b>Possible cause</b>	<b>Remedy</b>
Optical indication in driver's cab flashes rapidly	Tilt sensor b15 defective	Replace tilt sensor b15

<b>Switching on</b> (LED on PC board flashes with the same rate as the turn signal)		
<b>Fault</b>	<b>Possible cause</b>	<b>Remedy</b>
Optical indication in driver's cab flashes furiously	Lift arms switch b13 defective (short-circuit)	Replace lift arms switch b13
	Tilt sensor b15 guide rod defective	Replace tilt sensor b15
LED on PC board does not flash	ON/OFF switch in driver's cab defective	Check connections 2 and 4 with test lamp
	Fuses in unit e1 or e2 have tripped	Replace fuses
	PC board in sealing cover defective	Replace PC board

 <b>Open</b> (Platform opens to the horizontal operating position – this position is stored and moved to after the ground adjustment during lifting)		
<b>Fault</b>	<b>Possible cause</b>	<b>Remedy</b>
Platform does not open with motor	No signal at output J 1/3	Use test lamp to check according to circuit diagram
	Motor contactor defective	Check motor contactor
Platform does not open	Rotary switches, pushbuttons, or toggle switches defective	Use test lamp to check contacts in operating element according to circuit diagram, use ground connection JK at PC board
	No voltage at valve plug S 3 or S 4, defective cable	Check with test lamp
	Control valve S 5 or pressure splitter stuck	Clean or replace

**Open**

(Platform opens to the horizontal operating position – this position is stored and moved to after the ground adjustment during lifting)

Fault	Possible cause	Remedy
Warning lamps on platform are not flashing when platform is open	Tilt sensor b15 at the platform misadjusted or defective	Adjust or replace
	PC board defective	Replace
	Plugs defective	Replace
	Warning lamps defective	Replace
	Initiator b25 misadjusted or defective	Adjust or replace

**Extend**

Fault	Possible cause	Remedy
Platform does not extend, motor is running	Solenoid valves S 7 and S 8 leaking	Clean or replace
	Solenoid valve S 8 does not open	Clean or replace
	Lowering brake valve S 11 does not open	Clean or replace
	Piston seal in guide cylinder defective	Replace

**Fold out**

(model MBB R 1500 SH – R 2000 LH)

Fault	Possible cause	Remedy
Platform does not unfold, motor is running	Solenoid valves S 7 and S 8 leaking	Clean or replace
	Solenoid valve S 12 does not open	Clean or replace
	Valve S 10 does not open	Clean or replace
	Piston seal in folding cylinder defective	Replace

		
Fault	Possible cause	Remedy
Platform does not come down or too slowly, but opening operation works	Flow valve R 1 or R 2 at lift cylinder stuck or defective	Clean or replace
	Seating too tight	Grease all seating points
	Hydraulic oil too thick	Change oil, use oil grade as recommended
Platform does not come down when operated with foot controls	The foot controls were actuated too fast (less than 1 s) or too slow (more than 3 s) after each other	Release both foot controls, wait a few seconds, and repeat procedure
	Foot control defective	Disconnect plug connection in the platform, check foot controls with continuity tester
	Cable no. 2 to platform defective	Actuate both foot controls and check the voltage at plugs J 3/6 and J 3/5 on the PC board using a test lamp
Platform does not come down when operated with lateral operating element	Rotary switches, pushbuttons, or toggle switches defective	Use test lamp to check contacts in operating element according to circuit diagram, use ground connection JK at PC board
	PC board does not deliver output at J 4/15	Disconnect plug J 4, check terminal 15 with test lamp
	PC board does not deliver output at J 1/12	Disconnect plug J 1, check terminal 12 with test lamp
	No voltage at valve plug S 1 or S 2, defective cable	Check with test lamp
	Valve S 5 in unit does not switch on	Check with test lamp
Platform tilts during lowering	Lift arms switch b13 misadjusted	Adjust
Platform tilts automatically	Solenoid valves S 3 and S 4 at tilt cylinder contaminated or defective	Clean or replace
	Piston seal in tilt cylinder defective	Replace
Platform comes down automatically	Solenoid valves S 1 and S 2 at lift cylinder contaminated or defective	Clean or replace

 <b>Ground adjustment</b> (platform tilts)		
Fault	Possible cause	Remedy
<b>Emergency actuation:</b> Actuate "Open" (28) pushbutton and additional pushbutton (29) on lateral control element until platform tilts		
Platform does not tilt	Lift arms switch b13 misadjusted or defective	Adjust lift arms switch b13 so that the platform tilts after touching the ground
	PC board does not deliver output at J 4/14	Check at connection b1 (signal) of plug J 41 (lift arms switch) with test lamp
	No voltage at valve plug S 3 or S 4, defective cable	Disconnect plug J 4, check terminal 14 with test lamp
	Solenoid valves S 3 and S 4 at tilt cylinder contaminated or defective	Clean or replace
	PC board has stored error	De-energize, check with test lamp
	Flow valve R 5 or pressure splitter stuck or defective	Clean or replace
	PC board defective	Replace
Platform does not tilt, optical indicator in driver's cab flashes rapidly	Tilt sensor b15 guide rod defective	Replace tilt sensor b15

 <b>Lift platform off the ground</b> (platform tilts into the horizontal operating position that was stored when it was opened)		
Fault	Possible cause	Remedy
Platform does not tilt into the horizontal operating position when operated via foot controls	The foot controls were actuated too fast (shorter than 1 s) or too slow (longer than 3 s) after each other	Release both foot controls, wait a few seconds, and repeat procedure
	Foot control defective	Disconnect plug connection in the platform, check foot controls with continuity tester
	Cable no. 2 to platform defective	Actuate both foot controls and check the voltage at plugs J 3/6 and J 3/5 on the PC board using a test lamp
Platform does not tilt into the horizontal position when lifting	Directional valve S 5 stuck or defective	Clean or replace
	Tilt sensor b15 defective	Replace
Platform tilts further than the preset angle	Tilt sensor b15 defective	Replace
	Directional valve S 5 stuck or defective	Clean or replace
Platform does not tilt into the horizontal operating position but is lifted	PC board does not deliver output at J 1/12	Check plug J 1 terminal 12 with test lamp, use ground connection JK of the PC board
	Valve S 5 in unit does not switch on	Check with test lamp
Platform does not tilt into the horizontal operating position, but is lifted, optical indicator in driver's cab flashes rapidly	Tilt sensor b15 platform defective	Replace tilt sensor b15
Platform tilts further than the preset angle when the platform is lifted	Tilt sensor b15 defective	Replace
	Directional valve stuck or defective	Clean or replace

 <b>Lift</b> (platform moves up to loading edge)		
Fault	Possible cause	Remedy
Platform does not lift up	Rotary switches, pushbuttons, or toggle switches defective	Use test lamp to check contacts in operating element according to circuit diagram, use ground connection JK at PC board
	PC board does not deliver output at J 1/3	Check PC board according to circuit diagram at plug J 1/3 with test lamp
	Motor contactor in unit does not switch on or is defective	Check motor contactor with test lamp
Platform is not lifted up although hydraulic unit is running	Directional valve S 5 stuck or defective	Clean or replace
	Solenoid valves S 1 and S 2 at lift cylinder contaminated or defective	Clean or replace
	Suction filter at pump contaminated	Clean or replace
	Platform overloaded	Reduce load according to load diagram
	Hydraulic pump defective	Replace
	Electric motor defective	Replace
	Pressure splitter contaminated or defective	Clean or replace
	Pressure relief valve misadjusted or defective	Adjust and lock the valve or replace it

 <b>Close</b> (platform closes)		
Fault	Possible cause	Remedy
Platform does not close	Rotary switches, pushbuttons, or toggle switches defective	Check contacts in operating element according to circuit diagram using test lamp
	PC board does not deliver output at J 1/3 or J 1/1	Check PC board according to circuit diagram at plug J 1/3 and 1/12 with test lamp
	Motor contactor or valve S 5 in unit do not switch on	Check with test lamp
In its closed end position the platform does not reach the vehicle loading floor height	End of box insufficiently reinforced	Reinforce box according to the details in assembly drawing
	Bearings worn out (after longer usage)	Replace bearing pins, bearing bushes

 <b>Retract</b>		
Fault	Possible cause	Remedy
Platform does not retract, motor is running	Solenoid valves S 7 and S 8 leaking	Clean or replace
	Solenoid valve S 7 does not open	Clean or replace
	Solenoid valve S 11 does not open	Clean or replace
	Piston seal in guide cylinder defective	Replace

 <b>Fold in</b> (for model MBB R 1500 SH – R 2000 LH)		
Fault	Possible cause	Remedy
Platform does not unfold, motor is running	Solenoid valves S 7 and S 8 leaking	Clean or replace
	Solenoid valve S 12 does not open	Clean or replace
	Solenoid valve S 9 does not open	Clean or replace
	Piston seal in folding cylinder defective	Replace

<b>Switch on warning light</b> (warning light is automatically switched on when the platform is opened or extended, left and right lights are switched in parallel)		
Fault	Possible cause	Remedy
Warning lamps are not flashing	Short-circuit in lamp or cabling	Repair short-circuit
	Lamp defective	Replace
	Initiator b25 defective	Replace

## E Troubleshooting Tables

### Before switching on

Fault	Possible cause	Remedy
Optical indication in driver's cab flashes rapidly	Tilt sensor b15 defective	Replace tilt sensor b15

### Switching on

(LED on PC board flashes with the same rate as the turn signal)

Fault	Possible cause	Remedy
Optical indication in driver's cab flashes furiously	Lift arms switch b13 defective (short-circuit)	Replace tilt sensor b15
	Tilt sensor b15 guide rod defective	Replace tilt sensor b15
LED on PC board does not flash	ON/OFF switch in driver's cab defective	Check connections 2 and 4 with test lamp
	Fuses in power unit e1 or e2 have tripped	Replace fuses
	PC board in sealing cover defective	Replace PC board





### Open

(Platform opens to the horizontal operating position – this position is stored and moved to after the ground adjustment during lifting)

Fault	Possible cause	Remedy
Platform does not open	Rotary switches, pushbuttons, or toggle switches defective	Use test lamp to check contacts in operating element according to circuit diagram, use ground connection JK at PC board
	Motor contactor -K4 or relay -K5 defective	Check motor contactor and relay
	Output J4/14, JK or J43/90 does not deliver output signal	Use test lamp to check according to circuit diagram
Warning lights on platform are not flashing when platform is open	Tilt sensor b15 at the platform misadjusted or defective	Adjust or replace
	PC board defective	Replace
	Plugs defective	Replace
	Warning lamps defective	Replace

 <b>Lower</b>		
Fault	Possible cause	Remedy
Platform does not lower, but can be opened	Lift cylinder is stuck	Briefly press Lift pushbutton, then press Lower pushbutton again
	Seating too tight	Grease all seating points
	Output J4/15 or J42/81 does not deliver output signal	Use test lamp to check according to circuit diagram
	Motor contactor -K2 or relay -K7 defective	Check motor contactor and relay
Platform does not come down when operated with foot controls	Foot controls were actuated too fast (shorter than 1 s) or too slow (longer than 3 s) after each other	Release both foot controls, wait a few seconds, and repeat procedure
	Foot control defective	Disconnect plug connection in the platform, check foot controls with continuity tester
	Cable no. 2 to platform defective	Actuate both foot controls and check the voltage at plugs J 3/6 and J 3/5 on the PC board using a test lamp
Platform does not come down when operated with lateral operating element	Rotary switches, pushbuttons, or toggle switches defective	Use test lamp to check contacts in operating element according to circuit diagram, use ground connection JK at PC board
	Cable no. 3 to operating element defective	Actuate rotary switches one after another and check voltage across connector J30 according to circuit diagram using a test lamp
Platform tilts during lowering	Lift cylinder lowers too slowly or not at all	Lubricate bearings, briefly actuate Lift pushbutton, then press Lower pushbutton again

 <b>Ground adjustment</b> (platform tilts)		
Fault	Possible cause	Remedy
<b>Emergency actuation:</b>		
Actuate "Open" (28) pushbutton and additional pushbutton (29) on lateral control element until platform tilts		
Platform does not tilt	Output J4/15, J4/14, JK or J42/81 does not deliver output signal	Use test lamp to check according to circuit diagram
	Seating too tight	Grease all seating points
Platform does not tilt, opt. indicator in driver's cab flashes rapidly	Tilt sensor b15 guide rod defective	Replace tilt sensor b15

 <b>Lift platform off the ground</b> (platform tilts into the horizontal operating position that was stored when it was opened)		
Fault	Possible cause	Remedy
Platform does not tilt into the horizontal operating position when operated via foot controls	The foot controls were actuated too fast (shorter than 1 s) or too slow (longer than 3 s) after each other	Release both foot controls, wait a few seconds, and repeat procedure
	Foot control defective	Disconnect plug connection in the platform, check foot controls with continuity tester
	Cable no. 2 to platform defective	Actuate both foot controls and check the voltage at plugs J 3/6 and J 3/5 on the PC board using a test lamp
When being lifted, the platform does not tilt to its horizontal position or tilts beyond the pre-set position	Tilt sensor b15 defective	Replace
Platform does not tilt into the horizontal operating position but is lifted	Output J43/90, J1/12, JK or JK does not deliver output signal	Use test lamp to check according to circuit diagram
	Motor contactor -K3 is defective	Check motor contactor
Platform does not tilt into the horizontal operating position, but is lifted, optical indicator in driver's cab flashes rapidly	Tilt sensor b15 platform defective	Replace

 <b>Lift</b> (platform moves up to loading edge)		
Fault	Possible cause	Remedy
Platform does not lift up	Rotary switches, pushbuttons, or toggle switches defective	Use test lamp to check contacts in operating element according to circuit diagram, use ground connection JK at PC board
	PC board does not deliver output at J 1/3 or J 42/81	Use test lamp to check PC board according to circuit diagram
	Motor contactor -K1 defective	Check motor contactor

 <b>Close</b> (platform closes)		
<b>Fault</b>	<b>Possible cause</b>	<b>Remedy</b>
<b>Platform does not close</b>	<b>Rotary switches, pushbuttons, or toggle switches defective</b>	<b>Use test lamp to check contacts in operating element according to circuit diagram, use ground connection JK at PC board</b>
	<b>PC board does not deliver output on J 1/12, J43/90 or JK</b>	<b>Use test lamp to check PC board according to circuit diagram</b>
	<b>Motor contactor -K1 defective</b>	<b>Check motor contactor</b>
<b>In its closed end position the platform does not reach the vehicle loading floor height</b>	<b>End of box insufficiently reinforced</b>	<b>Reinforce box according to details in assembly drawing</b>
	<b>Bearings worn out (after longer usage)</b>	<b>Replace bearing pins, bearing bushes</b>

<b>Switch on Warnfix</b> (Warnfix is automatically switched on when the platform is opened or extended, left and right lights are switched in parallel)		
<b>Fault</b>	<b>Possible cause</b>	<b>Remedy</b>
<b>Warning light does not flash</b>	<b>Short-circuit in lamp or cabling</b>	<b>Repair short-circuit</b>
	<b>Lamp defective</b>	<b>Replace</b>

## V Troubleshooting Tables

### Before switching on

Fault	Possible cause	Remedy
Optical indication in driver's cab flashes rapidly	Tilt sensor b15 defective	Replace tilt sensor b15

### Switching on

(LED on PC board flashes with the same rate as the turn signal)

Fault	Possible cause	Remedy
LED on PC board does not flash	Fuses in unit e1 or e2 have tripped	Replace fuses
	PC board in sealing cover defective	Replace PC board





### Open

(platform opens until reaching operating position)

Fault	Possible cause	Remedy
Platform does not open with motor	Output J1/3 does not deliver output signal	Use test lamp to check according to circuit diagram
	Motor contactor defective	Check motor contactor
Platform does not open	Pushbutton defective	Use test lamp to check contacts in operating element according to circuit diagram, use ground connection JK at PC board
	No voltage at valve plug S4 or S5, defective cable	Check with test lamp
	Control valve S6 or pressure valve locked	Clean or replace
Warning lights on platform are not flashing when platform is open	Tilt sensor b15 at the platform misadjusted or defective	Adjust or replace
	PC board defective	Replace
	Plugs defective	Replace
	Warning lamps are defective	Replace

 <b>Lift</b> (platform moves up to loading edge)		
Fault	Possible cause	Remedy
Platform does not lift up	Pushbutton defective	Use test lamp to check contacts in operating element according to circuit diagram, use ground connection JK at PC board
	PC board does not deliver output at J 1/3	Check PC board according to circuit diagram at plug J 1/3 with test lamp
	Motor contactor in unit does not switch on or is defective	Check motor contactor with test lamp
	Thermoswitch tripped	Allow motor to cool down
Platform is not lifted up although hydraulic unit is running	Directional valve S 3 stuck or defective	Clean or replace
	Solenoid valves S 1 and S 2 at lift cylinder contaminated or defective	Clean or replace
	Suction filter at pump contaminated	Clean or replace
	Platform overloaded	Reduce load according to load diagram
	Hydraulic pump defective	Replace
	Electric motor defective	Replace
	Pressure splitter contaminated or defective	Clean or replace
	Pressure relief valve misadjusted or defective	Adjust and lock the valve or replace it

 <b>Lower</b> (platform moves down until reaching the ground)		
Fault	Possible cause	Remedy
Platform does not come down	Flow valve R 1 or R 2 at lift cylinder stuck or defective	Clean or replace
	Slide bearing sluggish	Clean and lubricate slide bearing
	Hydraulic oil too thick	Change oil, use oil grade as recommended
	Solenoid valve S 1 or S 2 defective	Clean or replace

 <b>Lower</b> (platform moves down until reaching the ground)		
Fault	Possible cause	Remedy
Platform does not come down when operated with hand cable control	Pushbutton defective	Use test lamp to check contacts in operating element according to circuit diagram, use ground connection JK at PC board
	PC board does not deliver output at J 4/15	Disconnect plug J 4, check terminal 15 with test lamp
	No voltage at valve plug S 1 or S 2, defective cable	Check with test lamp
Platform comes down automatically	Solenoid valves S 1 and S 2 at lift cylinder contaminated or defective	Clean or replace

 <b>Fold out</b>		
Fault	Possible cause	Remedy
Link bridge does not fold out, motor is running	Solenoid valves S 10 and S 11 do not open	Clean or replace
	Solenoid valve S 7 does not open	Clean or replace
	Piston seal in tilt cylinder defective	Replace

 <b>Fold in</b>		
Fault	Possible cause	Remedy
Link bridge does not fold in, motor is running	Solenoid valve S 7 does not open	Clean or replace
	Solenoid valve S 12 does not open	Clean or replace
	Solenoid valve S 13 does not open	Clean or replace
	Piston seal in tilt cylinder defective	Replace

<b>Switch on Warnfix</b> (Warnfix is automatically switched on when the platform is opened, left and right lights are switched in parallel)		
<b>Fault</b>	<b>Possible cause</b>	<b>Remedy</b>
<b>Warning light does not flash</b>	<b>Short-circuit in lamp or cabling</b>	<b>Repair short-circuit</b>
	<b>Lamp defective</b>	<b>Replace</b>

 <b>Close</b> (platform closes)		
<b>Fault</b>	<b>Possible cause</b>	<b>Remedy</b>
<b>Platform does not close at all or only on one side</b>	<b>Emergency control of tilt cylinder activated or both activated.</b>	<b>Screw out knurled screws of solenoid valves</b>
<b>Platform does not close</b>	<b>Pushbutton defective</b>	<b>Check contacts in operating element according to circuit diagram using test lamp</b>
	<b>PC board does not deliver output at J 1/3 or J 43/93</b>	<b>Check PC board according to circuit diagram at plug J 1/3 and 43/93 with test lamp</b>
	<b>Motor contactor or valve S 7 in unit do not switch on</b>	<b>Check with test lamp</b>
	<b>Initiator B 25 defective</b>	<b>Check with test lamp according to circuit diagram, replace if required</b>

## Technical Data

### All Models

#### Recommended Battery Capacity

Load weight [kg]	Recommended battery capacity
up to 1250	12 V = 1 x 143 Ah 24/12 V, 24 V = 2 x 12 V, 2 x 105 Ah
1250 to 1750	12 V = 1 x 180 Ah 24/12 V, 24 V = 2 x 12 V, 2 x 143 Ah
over 1750 to 4000	24/12 V, 24 V = 2 x 12 V, 2 x 180 Ah

**Note:** If you use the vehicle exclusively for short-haul transports in urban traffic frequent loading operations, you should a battery of the next higher capacity level. In addition it is recommended to use a stronger alternator.

### All Models

#### Alternators for Recharging the Battery

Load weight [kg]	Recommended alternator [Watt]
up to 1250	630
1250 to 1750	730
over 1750 to 4000	1000

### All Models

#### Temperature Range for Tail Lift Usage

Standard	"Cold climate" option
-20 °C to +60 °C	-40 °C to +60 °C

## Load Diagrams

The following tables show the maximum allowed weight of the payload ( $Q$ ). The table applicable for your tail lift can also be found on the lateral operating element.

The payload ( $Q$ ) comprises everything placed on the platform, e. g. the transported goods, the operator, and any material handling equipment.

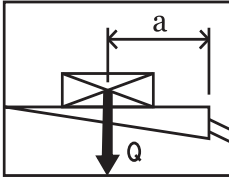

The maximum permissible payload ( $Q$ ) depends on the load distance ( $a$ ). The load distance ( $a$ ) is the distance between the rear edge of the truck load area and the payload center of gravity (**12**).

The maximum permissible payload ( $Q$ ) for the respective maximum permissible load distance ( $a$ ) is permanently indicated on the platform surface with corresponding markings.

### DANGER!



#### Risk of personal injury and material damage!

If the maximum permissible payload ( $Q$ ) or the maximum permissible load distance ( $a$ ) is exceeded, the tail lift could fall down! This can result in personal injuries or the tail lift could be severely damaged. In such a case any warranties shall become void!

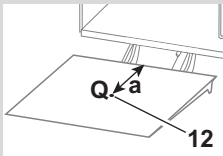

When you position the payload ( $Q$ ) in the center between the left and right platform edge:

- Load the tail lift not heavier than the payload ( $Q$ ), which is indicated in the table next to the respective load distance ( $a$ )!

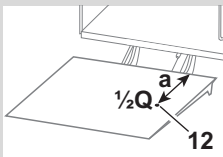

When you position the payload ( $Q$ ) at the left or right platform edge:

- Load the tail lift **not heavier than half the payload** ( $1/2Q$ ), which is indicated in the table next to the respective load distance ( $a$ )!

A

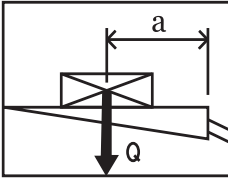

	a [mm]	Q [kg]		a [mm]	Q [kg]
<b>MBB</b>	600	750	<b>MBB</b> <b>C 1750 LD</b> <b>C 1750 SZD</b>	850	1750
<b>C 750 S</b>	700	650		1000	1450
<b>C 750 L</b>	820	550		1300	1150
<b>C 750 LX</b>	1120	400		1650	900
<b>C 750 SX</b>	1800	250		2400	600
<b>C 750 SPL</b>					
<b>MBB</b>	600	1000	<b>MBB</b> <b>C 2000 L</b> <b>C 2000 LZ</b> <b>C 2000 LK</b> <b>C 2000 LX</b>	750	2000
<b>C 1000 L</b>	750	800		900	1650
<b>C 1000 SPL</b>	950	600		1100	1300
<b>C 1000 SPR</b>	1400	400		1600	950
<b>C 1000 ML</b>	2400	230		2400	600
<b>C 1000 ML PRO</b>					
	700	1000	<b>MBB</b> <b>C 2000 S</b> <b>C 2000 SK</b>	1000	2000
<b>MBB</b>	875	800		1200	1650
<b>C 1000 S</b>	1150	600		1500	1350
<b>C 1000 SB</b>	1700	400		1800	1100
	2400	250		2100	950
	720	1250	<b>MBB</b> <b>C 2500 L</b>	750	2500
<b>MBB</b>	900	1000		900	2050
<b>C 1250 LD</b>	1200	750		1100	1700
	1800	500		1600	1150
	2400	370		2400	750
<b>MBB</b>	600	1500	<b>MBB</b> <b>C 2500 S</b> <b>C 2500 SK</b> <b>C 2500 SZ</b>	1000	2500
<b>C 1500 L</b>	720	1250		1400	1785
<b>C 1500 LB</b>	900	1000		1600	1560
<b>C 1500 LX</b>	1200	750		1800	1385
<b>C 1500 ML</b>	2400	370		2400	1040
<b>C 1500 ML PRO</b>					
	1000	1500	<b>MBB</b> <b>C 3000 S</b>	1000	3000
<b>MBB</b>	1200	1250		1200	2000
<b>C 1500 S</b>	1500	1000		1500	1600
<b>C 1500 SZ</b>	1850	800		1800	1300
<b>C 1500 SK</b>	2400	600		2400	1000

**B**

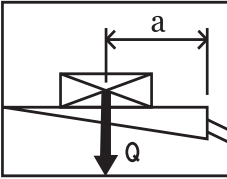

	a [mm]	Q [kg]
<b>MBB C 500 LG</b>	600	500
	700	430
	820	360
	1120	260
	1800	160

**C**

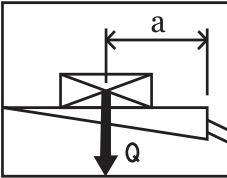

	a [mm]	Q [kg]
<b>MBB C 350 VAN</b>	850	350
	1000	300
	1200	250
	1500	200
	1800	160

	a [mm]	Q [kg]
<b>MBB C 500 VAN</b>	600	500
	700	430
	820	360
	1120	260
	1800	160

**E**

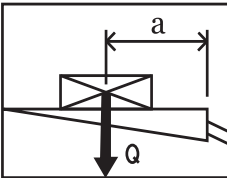

	a [mm]	Q [kg]
<b>MBB C 1000 E</b>	600	1000
	750	800
	950	600
	1400	400
	2400	230

**F**

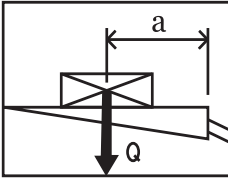

	a [mm]	Q [kg]		a [mm]	Q [kg]
<b>MBB R 750 L</b>	600	750	<b>MBB R 2000 L R 2000 LK R 2000 L TRAIL R 2000 L TRUCK</b>	750	2000
	700	650		900	1650
	820	550		1100	1300
	1120	400		1600	950
	1800	250		2400	600
<b>MBB R 1000 S R 1000 S TRUCK</b>	700	1000	<b>MBB R 2000 S</b>	1000	2000
	875	800		1200	1650
	1150	600		1500	1350
	1700	400		1800	1100
	2400	250		2100	950
<b>MBB R 1500 L R 1500 L FLAT R 1500 LX FLAT</b>	600	1500	<b>MBB R 2500 L R 2000 L TRAIL</b>	750	2500
	720	1250		900	2050
	900	1000		1100	1700
	1200	750		1600	1150
	2400	370		2400	750
<b>MBB R 1500 S R 1500 SK R 1500 S TRAIL R 1500 S TRUCK</b>	1000	1500	<b>MBB R 2500 S</b>	1000	2500
	1200	1250		1400	1785
	1500	1000		1600	1560
	1850	800		1800	1385
	2400	600		2400	1040

**G**

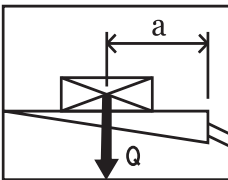

	a [mm]	Q [kg]		a [mm]	Q [kg]
<b>MBB R 750 SM</b>	600	750	<b>MBB R 1500 SM R 1500 SH</b>	1000	1500
	700	650		1200	1250
	820	550		1500	1000
	1120	400		1850	800
	1800	250		2400	600
<b>MBB R 1000 LM</b>	600	1000	<b>MBB R 2000 LM R 2000 LH</b>	750	2000
	750	800		900	1650
	950	600		1100	1300
	1400	400		1600	950
	2400	230		2400	600

**K**

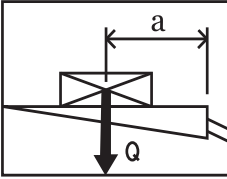

	a [mm]	Q [kg]
<b>MBB F 1000 SH F 1000 SX</b>	600	1000
	750	800
	1000	600
	1500	400
	2400	250
<b>MBB F 1500 LH F 1500 LX</b>	600	1500
	720	1250
	900	1000
	1200	750
	2400	370

	a [mm]	Q [kg]
<b>MBB F 2000 LH</b>	750	2000
	900	1650
	1100	1300
	1600	950
	2400	600

**L**

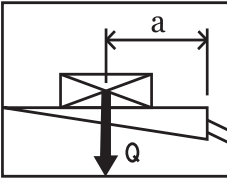

	a [mm]	Q [kg]
<b>MBB F 1000 L</b>	600	750
	700	650
	820	550
	1120	400
	1800	250
<b>MBB F 1000 LD</b>	650	1000
	850	800
	1150	600
	1700	400
	2400	250

	a [mm]	Q [kg]
<b>MBB F 1250 S</b>	550	1250
	650	1000
	900	750
	1350	500
	2400	250
<b>MBB F 1500 L</b>	600	1500
	720	1250
	900	1000
	1200	750
	2400	370

**M**

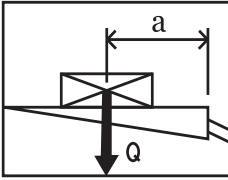

	a [mm]	Q [kg]
<b>MBB F 500 L</b>	600	500
	700	430
	820	360
	1120	260
	1800	160

	a [mm]	Q [kg]
<b>MBB F 600 L</b>	600	600
	700	430
	820	360
	1120	260
	1600	160

**V**

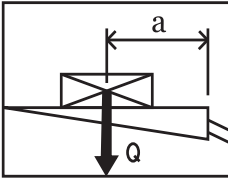

	a [mm]	Q [kg]
<b>MBB V 4000 S</b>	1500	4000
	1750	3400
	2000	3000
	2250	2600
	2500	2400

## Hydraulic Diagrams

### A K Standard Tail Lift with Four Cylinders 96-560.98-00.00-00

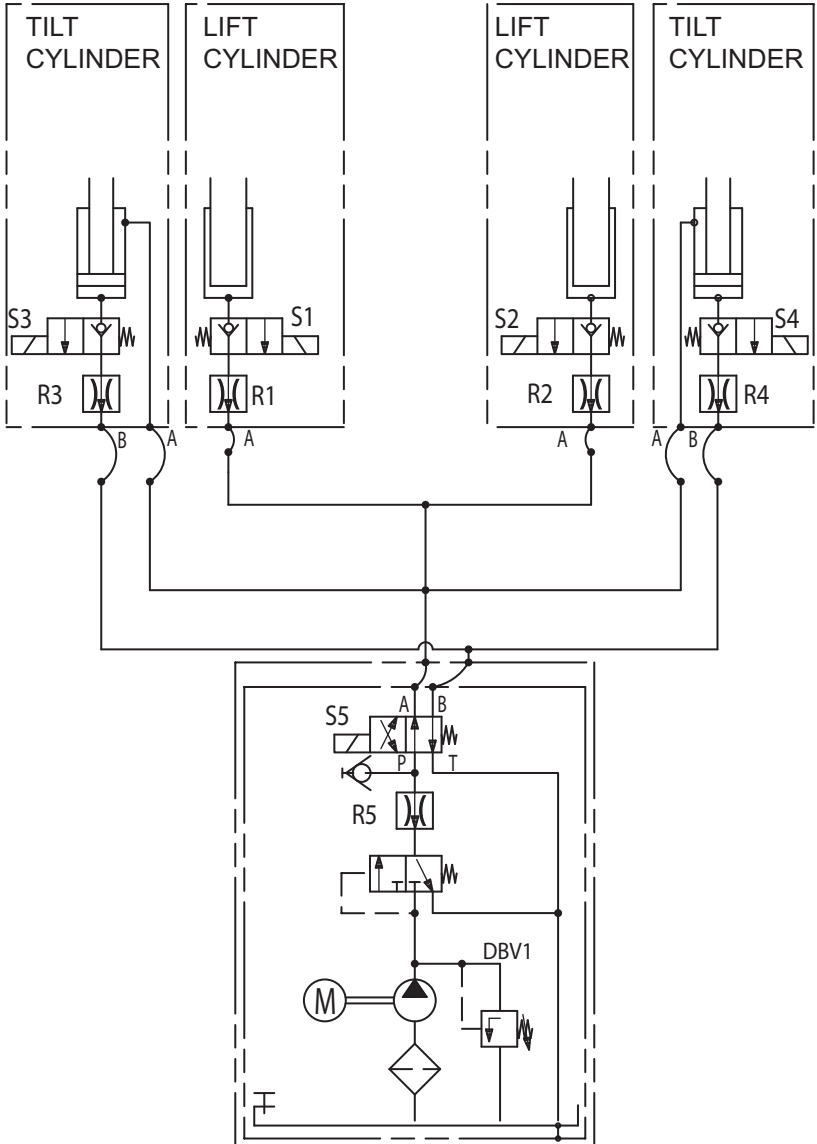

**A C** Standard Tail Lift with Two Cylinders  
97-510.98-00.00-00

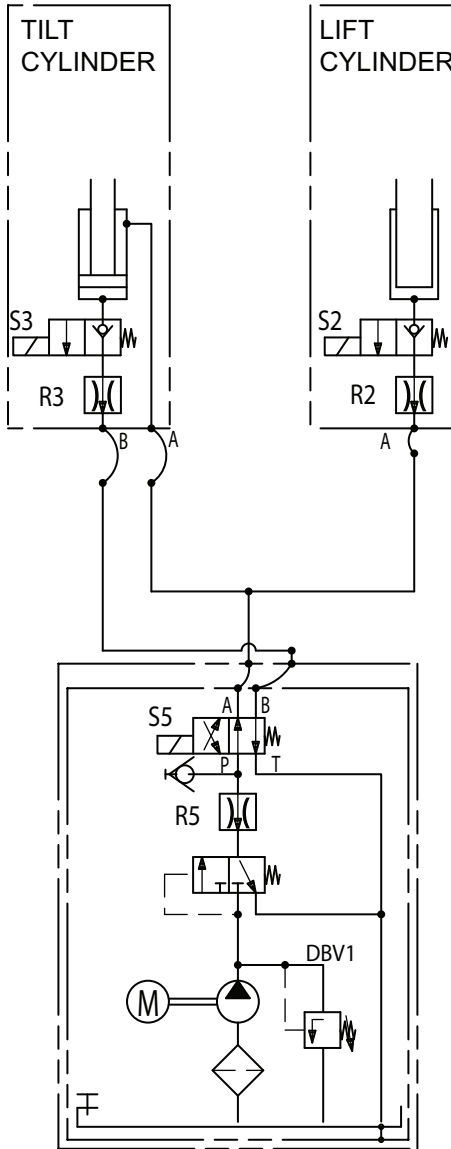

**A** Standard Tail Lift with Hydraulic Support  
96-524.98-01.00-00

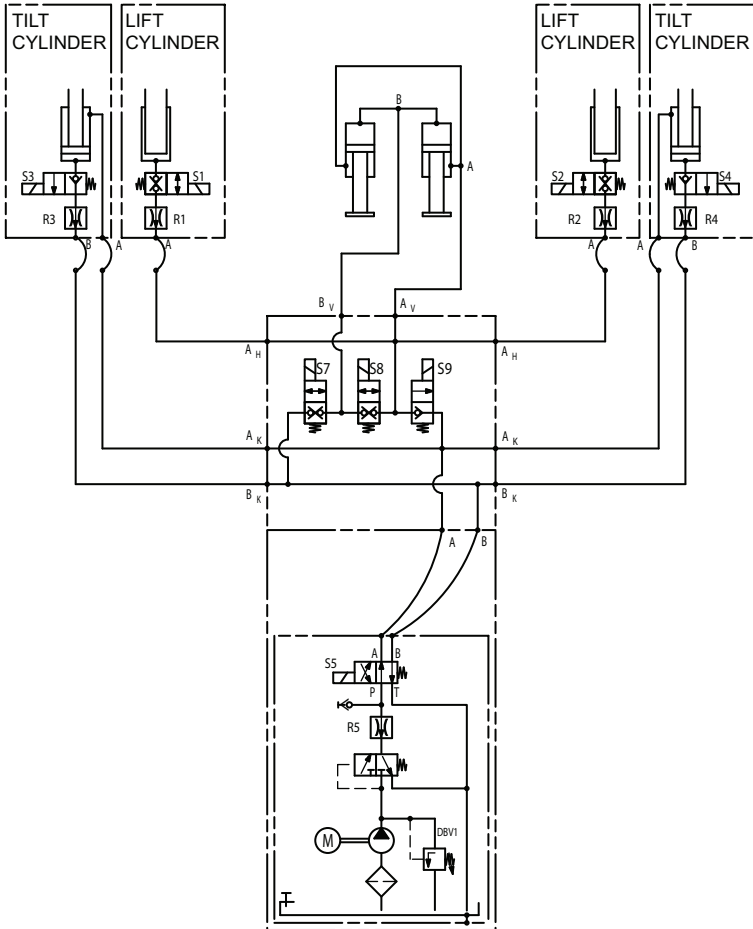

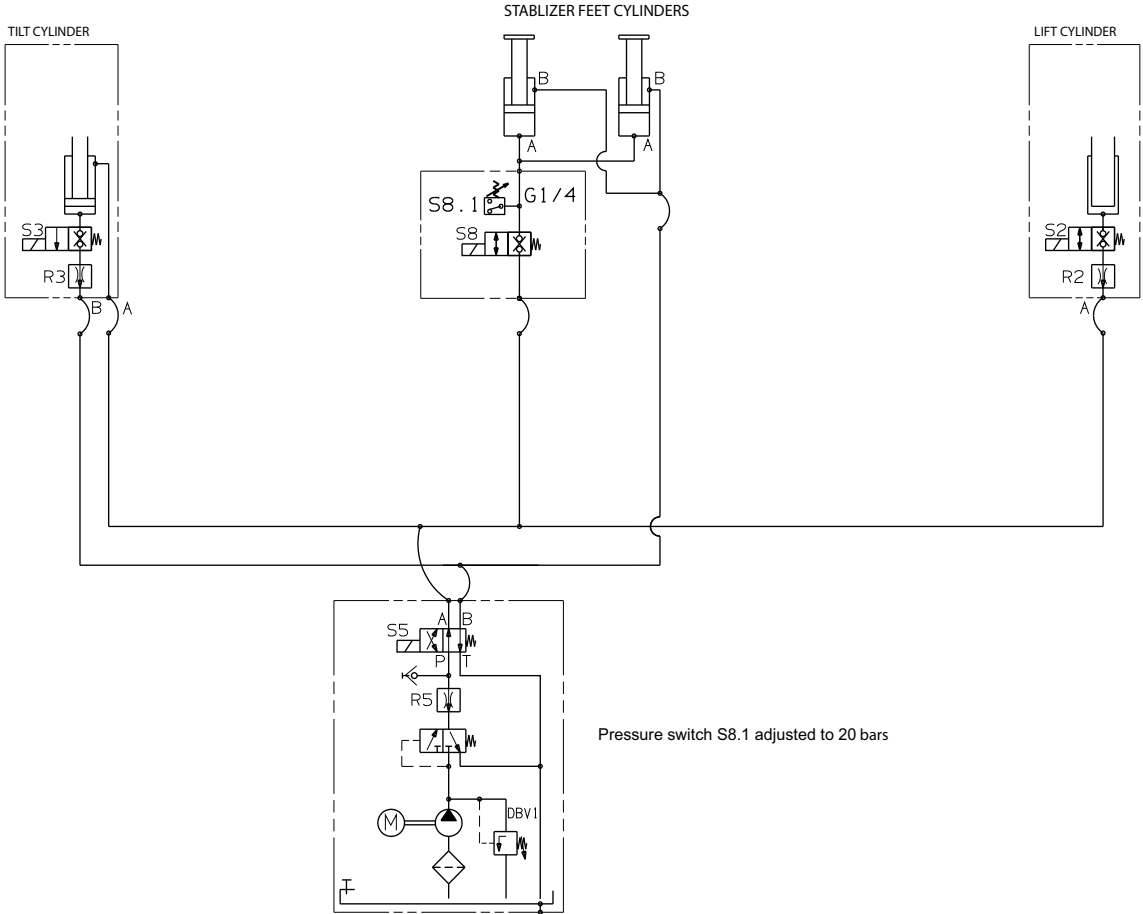

**A** Tail lift with hydraulic stabilizer feet  
 MBB C 750 L – C 1000 L

**A** Standard Tail Lift with Hydraulic Underrun Bumper  
99-514.98-01.00-00

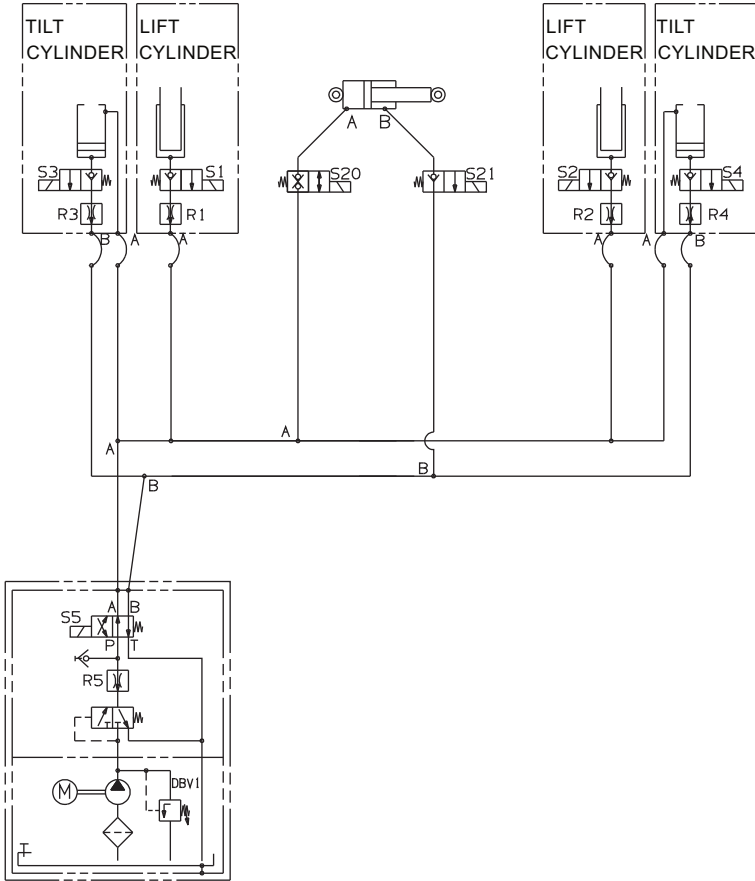

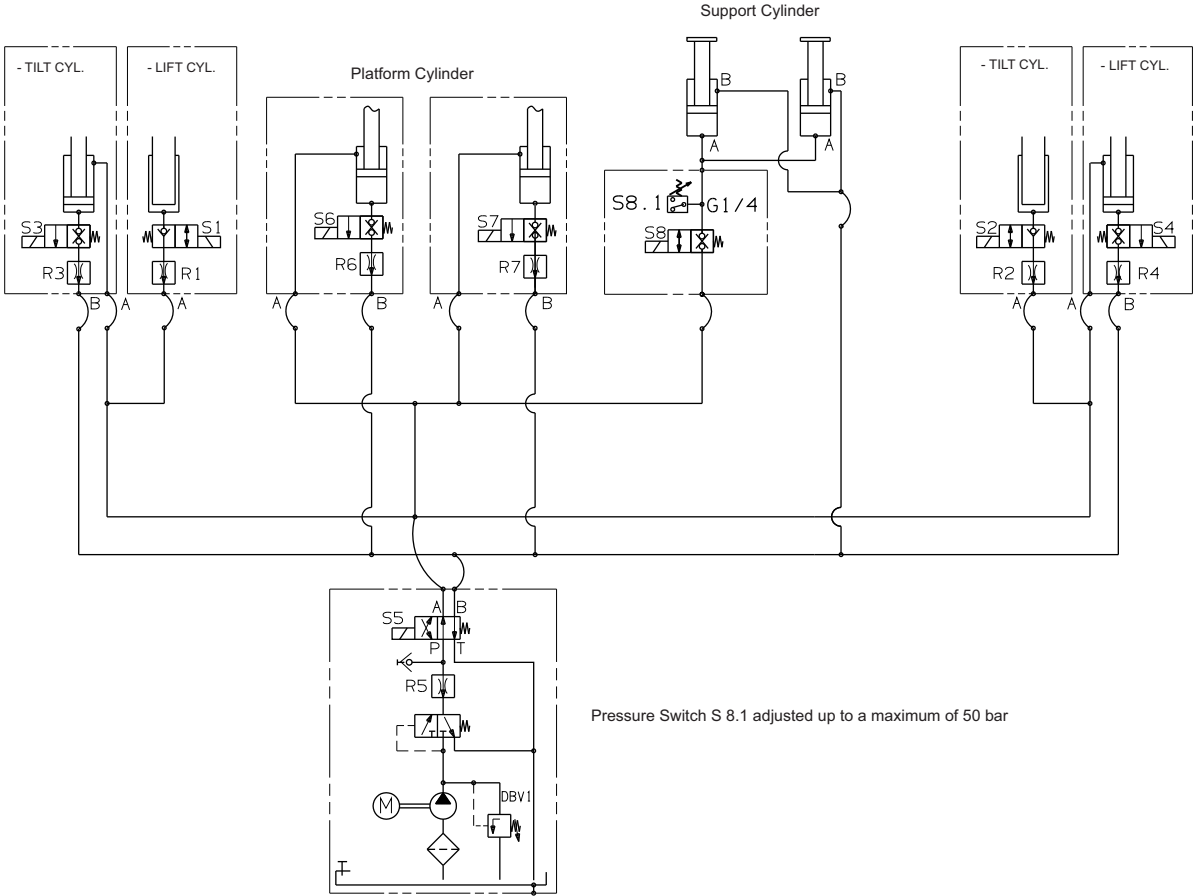

Pressure Switch S 8.1 adjusted up to a maximum of 50 bar

**A** Standard Tail Lift MBB C 750 SX  
13-631.98-02.00-00/3

**A Standard Tail Lift MBB C 1000 SB-C 1500 LB**  
 13-570.98-02.00-00

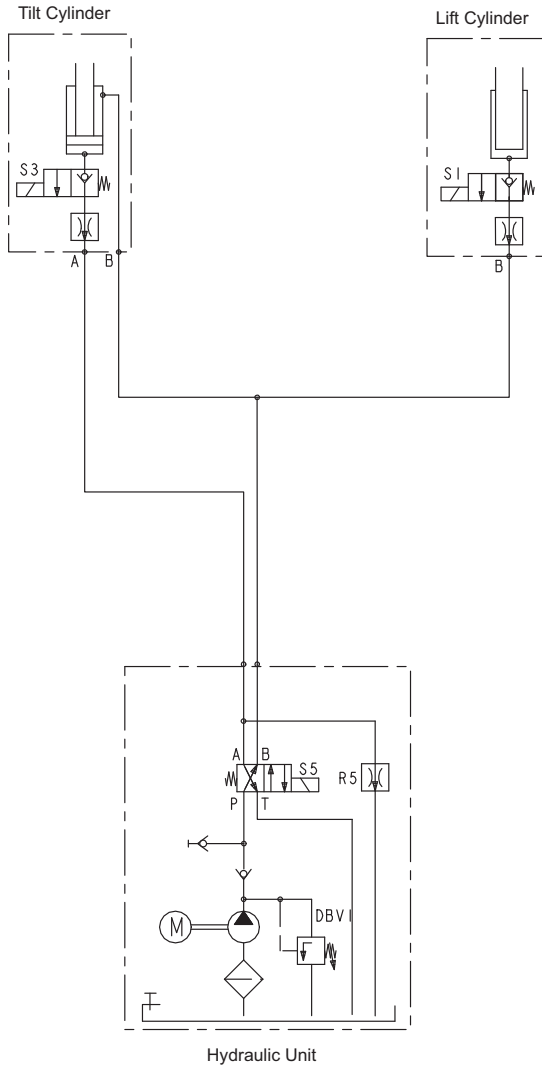

**A** Standard Tail Lift MBB C 1000 SB-C 1500 LB with Pressure Intensifier  
13-570.98-01.00-00

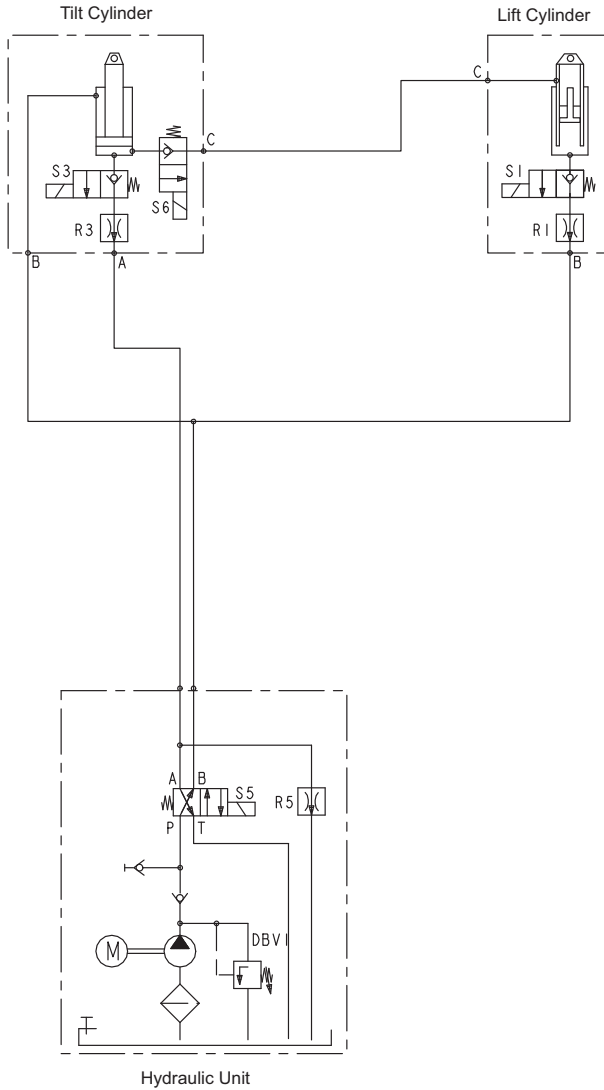

**F G** Retractable Tail Lift  
95-585.98-01.00-00

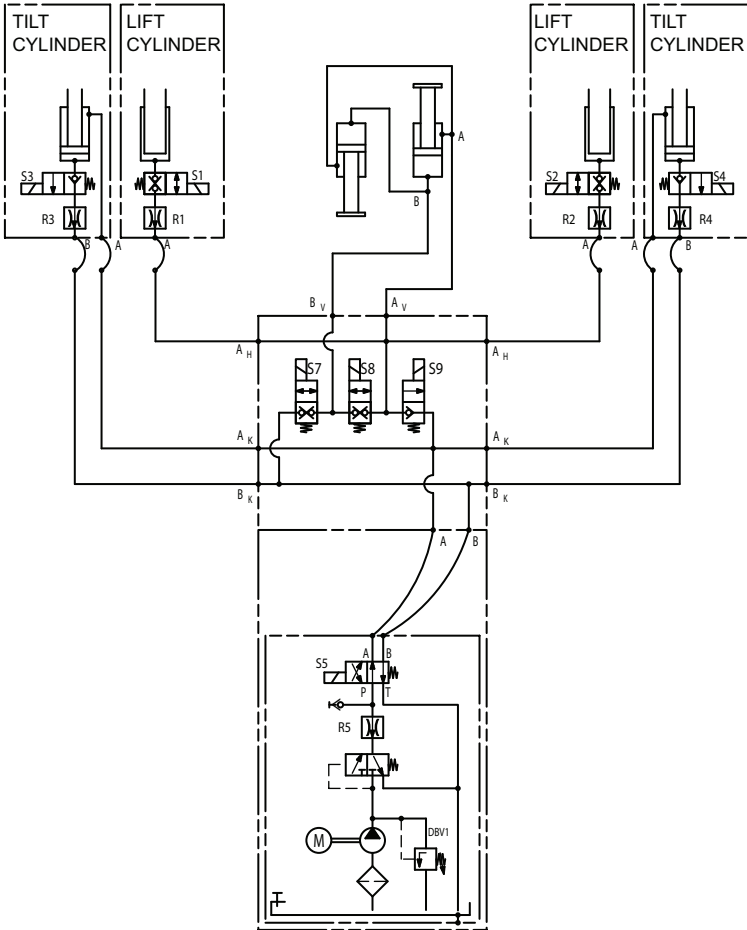

**F** Retractable Tail Lift MBB R 750 L, R 750 SM,  
**R 1000 LM, R 1500 SK and R 2000 LK**  
 00-538.01-98.01-00/3

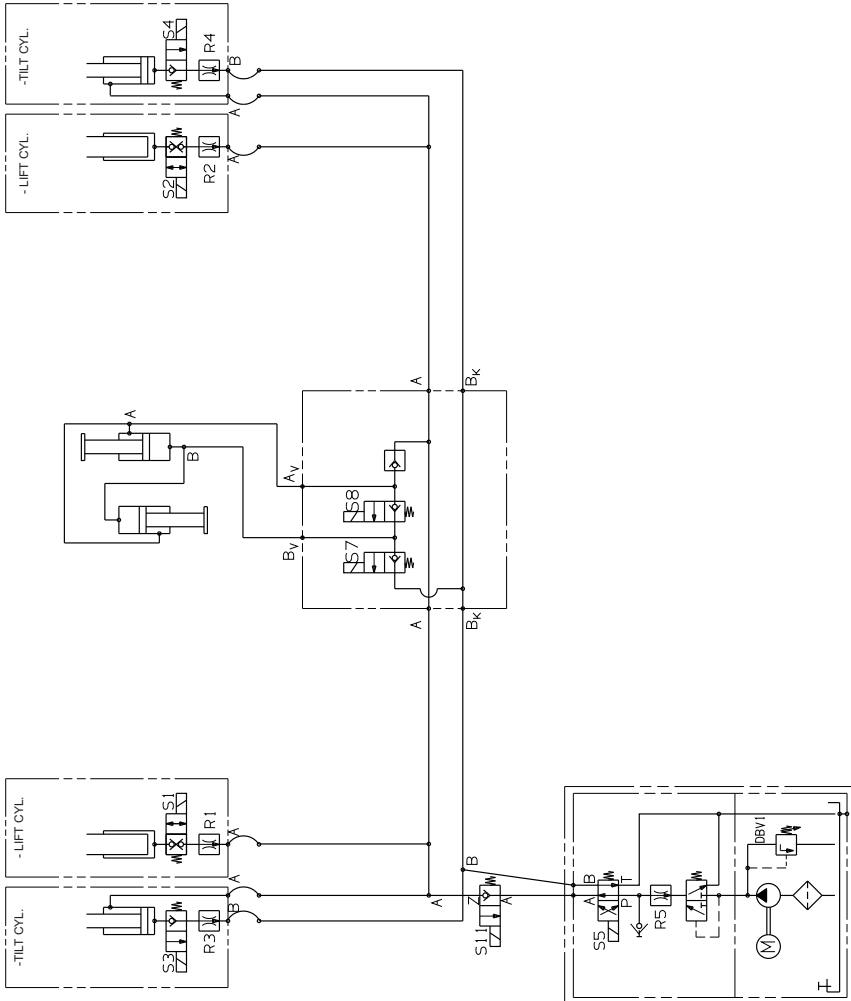

**F** Retractable Tail Lift MBB R 1500 L FLAT  
99-553.98-01.00-00/3

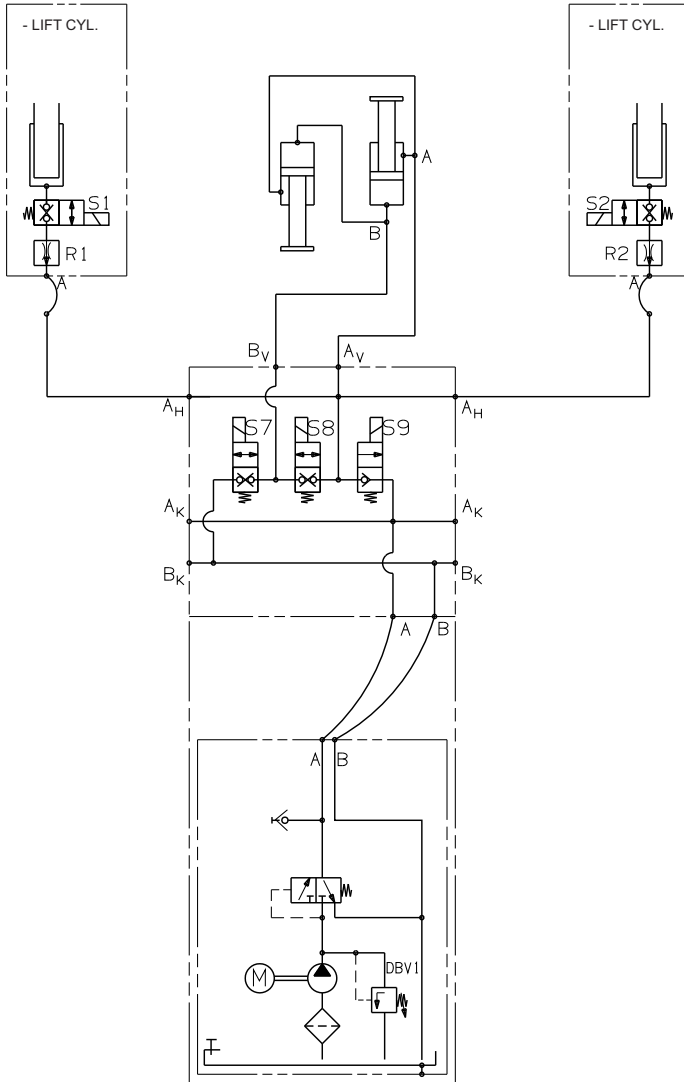

**G** Retractable Tail Lift MBB R 1500 SH and R 2000 LH  
00-514.98-00.00-00

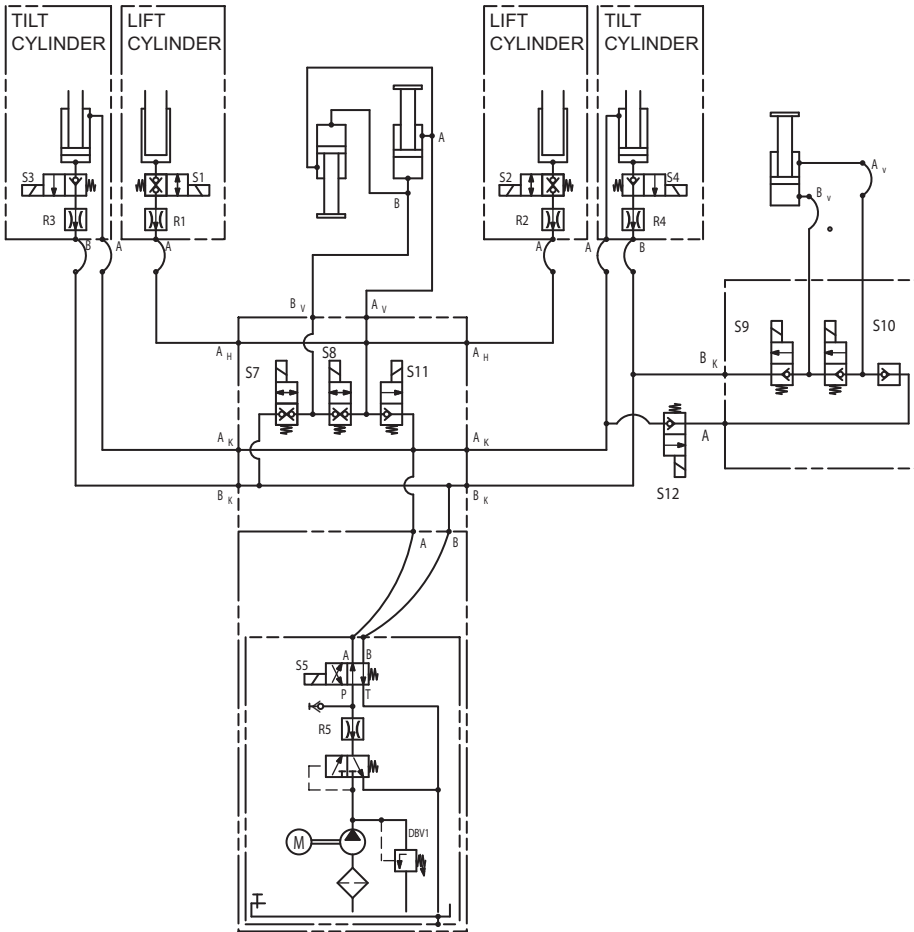

**L** **Foldable Tail Lift**  
93-505.60-08.00-00

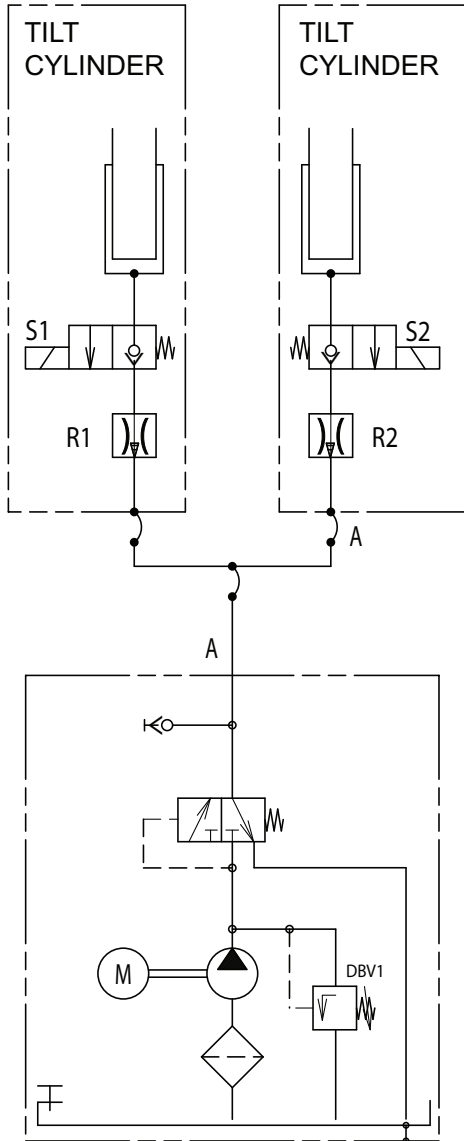

**B M** **Foldable Tail Lift**  
02-528.60-08.00-00

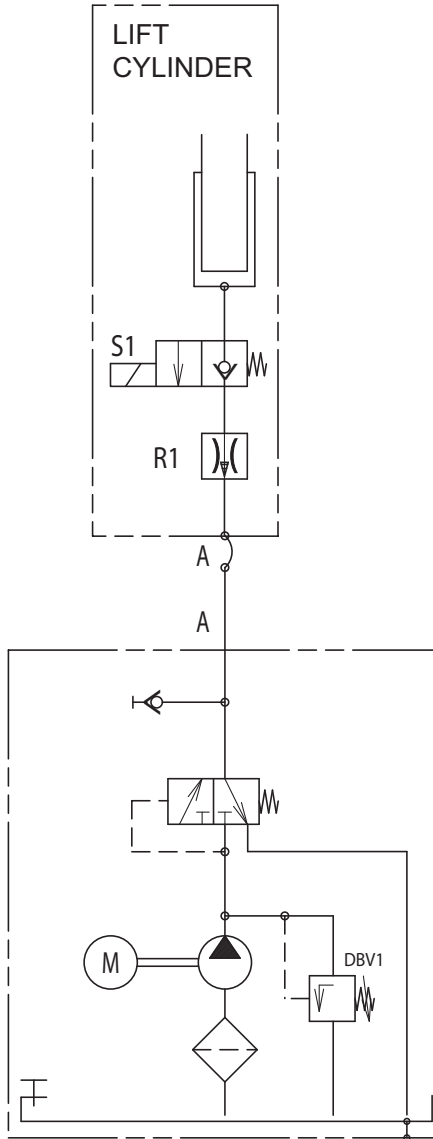

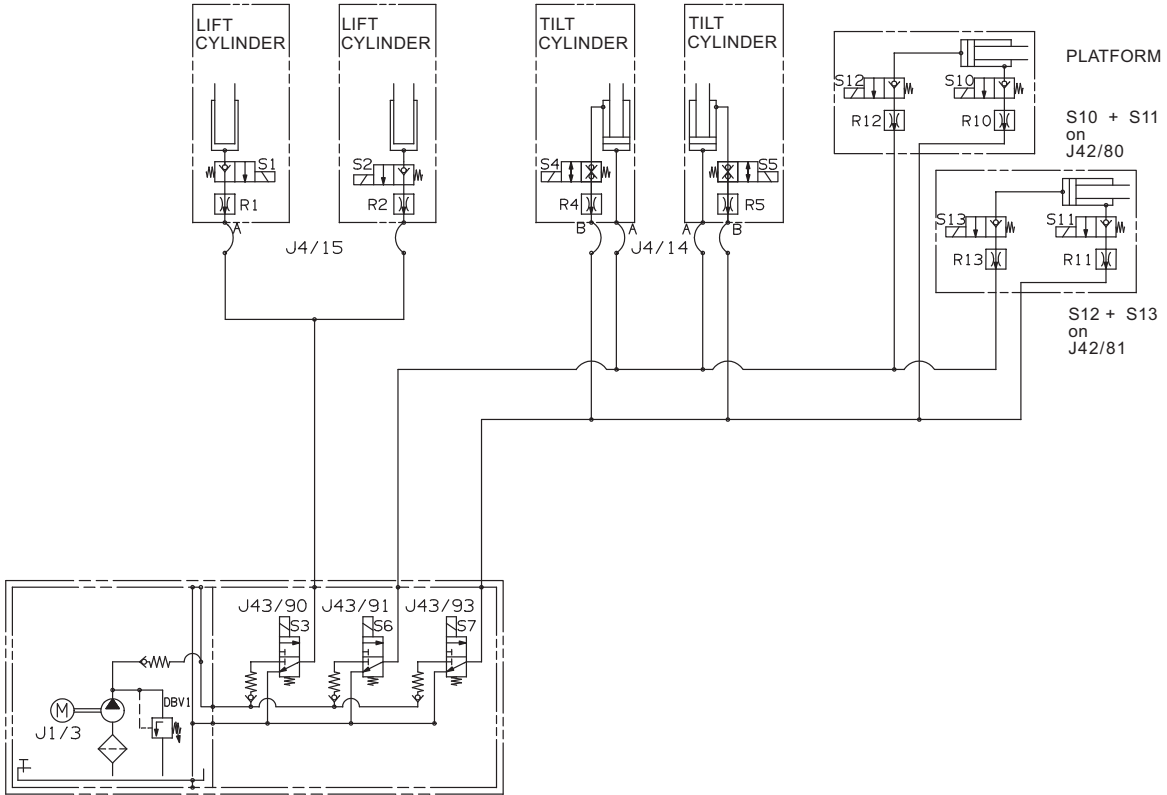

# Lubricants and Operating Media

## Recommended Hydraulic Oil Grades

- Shell Tellus S2 V 15  
operation temperature:  $-20\text{ }^{\circ}\text{C}$  to  $60\text{ }^{\circ}\text{C}$
- Aero Shell Fluid 41  
Operation temperature:  $-54\text{ }^{\circ}\text{C}$  to  $90\text{ }^{\circ}\text{C}$

"Cold climate" option

- Aero Shell Fluid 41 and low temperature gaskets against vitrification of sealing material  
Operation temperature: up to  $-54\text{ }^{\circ}\text{C}$

## Environment-friendly Oils

Increasing awareness for the environment calls for environment-friendly, biodegradable oils for hydraulic equipment. On request we can supply you with an oil grade tested by us. The operation temperature of this oil is listed as  $-20\text{ }^{\circ}\text{C}$  to  $60\text{ }^{\circ}\text{C}$ . Please contact us.

When using other oil types, this may result in damage to cylinder seals or annoying noise.

## Recommended Lubricant Grease

- Shell Gadus S2 (Heavy duty grease)
- Comparable lubricant grease

## Available Accessories

The available accessories are listed in the spare parts catalog of your contractor repair shop. The list of repair shops shows you the nearest repair shop and provides further contact information.

## Certificate for securing a load with tail lifts Requirements specification and load prerequisites

### 1. Information on the tail lifts

Tail lifts manufacturer:	MBB PALFINGER GmbH Fockestraße 53 27777 Ganderkesee
Tail lifts type	Standard - HLB with 2 tipping and 2 lifting cylinders
with platforms:	Aluminum and steel
Control arm length:	up to 1,100 mm

**The tail lifts fulfill the requirements of DIN EN 12642 Code XL.**

### 2. Information on types and equipment for tail lifts

The tail lifts is to secure loads in the location named under point 4 under maintenance of the loading conditions named under point 3, if the following equipment components are present:

	Permissible load masses	Demonstrated max. test forces (DIN EN 12642)
<b>2.1. Tail Lift load capacity 500 kg to 750 kg – all pitches</b>		
Platform dimensions:	Height: 1,200 – 2,000 mm Width: 1,750 – 2,600 mm Bearing bolt diameter Ø25 mm	
Control arm length:	600 to 800 mm	
Nominal load:	500 kg to 750 kg	
<b>Platform heights : up to 2,000 mm</b>	<b>5,000 kg</b>	<b>1,500 daN</b>
<b>2.2. Tail Lift load capacity 500 kg to 1000 kg – support tube ST180 and all pitches</b>		
Platform dimensions:	Height: 1,200 – 2,000 mm Width: 1,750 – 2,600 mm Bearing bolt diameter Ø25 mm	
Control arm length:	600 to 800 mm	
Nominal load:	500 kg to 1,000 kg	
<b>Platform heights : up to 1,600 mm</b>	<b>8,000 kg</b>	<b>2,400 daN</b>
<b>Platform heights : up to 1,800 mm</b>	<b>7,500 kg</b>	<b>2,250 daN</b>
<b>Platform heights : up to 2,000 mm</b>	<b>7,000 kg</b>	<b>2,100 daN</b>
<b>2.3. Tail Lift load capacity 1000 kg to 1500 kg – all pitches</b>		
Platform dimensions:	Height: 1,200 – 2,600 mm Width: 1,750 – 2,600 mm Bearing bolt diameter Ø28 mm	
Control arm length:	700 to 900 mm	
Nominal load:	1,000 kg to 1,500 kg	
<b>Platform heights : up to 2,000 mm</b>	<b>12,000 kg</b>	<b>3,600 daN</b>
<b>Platform heights : up to 2,200 mm</b>	<b>11,000 kg</b>	<b>3,300 daN</b>
<b>Platform heights : up to 2,400 mm</b>	<b>10,000 kg</b>	<b>3,000 daN</b>
<b>Platform heights : up to 2,600 mm</b>	<b>9,000 kg</b>	<b>2,700 daN</b>

**This certificate is comprised of 2 pages and is only valid in its complete form.**



**2.4. Tail Lift load capacity 1500 kg to 2500 kg – all pitches**

Platform dimensions: Height: 1,200 – 2,800 mm  
 Width: 1,750 – 2,600 mm  
 Bearing bolt diameter Ø36 mm  
 Control arm length: 700 to 1,100 mm  
 Nominal load: 1,500 kg to 2,500 kg

**Permissible load masses**      **Demonstrated max. test forces (DIN EN 12642)**

Platform heights : up to 2,000 mm	16,000 kg	4,800 daN
Platform heights : up to 2,200 mm	14,500 kg	4,350 daN
Platform heights : up to 2,400 mm	13,000 kg	3,900 daN
Platform heights : up to 2,600 mm	11,500 kg	3,450 daN
Platform heights : up to 2,800 mm	10,000 kg	3,000 daN

**2.5. Tail Lift load capacity 2000 kg to 3000 kg – all pitches**

Platform dimensions: Height: 1,200 – 3,000 mm  
 Width: 1,750 – 2,600 mm  
 Bearing bolt diameter Ø40 mm  
 Control arm length: 800 to 1,100 mm  
 Nominal load: 2,000 kg to 3,000 kg

Platform heights : up to 2,000 mm	21,000 kg	6,300 daN
Platform heights : up to 2,200 mm	19,000 kg	5,700 daN
Platform heights : up to 2,400 mm	17,000 kg	5,100 daN
Platform heights : up to 2,600 mm	15,000 kg	4,500 daN
Platform heights : up to 2,800 mm	13,000 kg	3,900 daN
Platform heights : up to 3,000 mm	11,000 kg	3,300 daN

**The condition of the tail lifts is to be inspected regularly according to VDI 2700.**

**3. Information on the loading**

The tail lifts are in the position to secure loads in the location named under point 4 under maintenance of the listed equipment named under point 3 under the following loading conditions:

- Sliding-friction value of a least  $\mu_D = 0.30$
- Form-fit loading against driving direction
- Loading with clearance at least tail lifts width less 10 cm

**4. Information on load**

The tail lifts is assured for the following loads under maintenance of the conditions listed under point 2 and 3, according to the parameters of recognized rules of technology, e.g. acceleration values according to DIN EN 12195-1, of the VDI directives 2700 following pages and the certificates and appraisals.

- General cargo
- Palletized loading

TÜV NORD Mobilität GmbH & Co. KG

**MBB PALFINGER GmbH**  
 Ganderkesee

Hannover, 25.03.2015

Martin Keller

Signature of the responsible party

**This certificate is comprised of 2 pages and is only valid in its complete form.**

# Index

- A**  
accessories 178  
alternators 156  
annual maintenance 133
- B**  
battery capacity 156  
battery check 124  
Battery main switch 26, 37  
bolts check 132  
breather filter 134, 136  
bringing down the platform 32
- C**  
carbon brush check 124  
checks 138  
clamp 136  
cleaning 124  
closing the platform 32  
conical lubricating head 126  
control panel 12
- D**  
Driver's cab control unit 37
- E**  
easy move 58, 62  
Einhandsteuerung  
    hydraulische Stützen 52  
explanation of terms 32  
extending the platform 32, 33
- F**  
faults 139
- troubleshooting tables 141, 148, 152  
folding in the platform 32  
folding out the platform 32  
folding part of platform 14  
foot control 14, 98
- G**  
greasing 125  
ground adjustment of platform 22, 33, 42  
guide cylinder 14  
guide pulley 14  
guide rails 14
- H**  
Hand cable control 100, 102, 105  
hand cable control 14  
holding bar on platform 14  
hydraulic diagrams 163  
hydraulic oil  
    changing 133, 136  
    environment-friendly oils 178  
    recommendations 178  
hydraulic oil reservoir 134, 136  
hydraulic stabilizer feet 27  
hydraulic system check 132  
hydraulic unit 14
- K**  
key code 26, 37  
    programming 116  
key control 26, 36
- L**  
lateral operating element 38  
lateral operating panel 14

lift arms switch 14  
 lift cylinder 14  
 lifting the platform 32  
 low-maintenance bearings 133  
 lubricants 178  
 lubricating 125

## M

main switch 138  
 maintenance 120  
     annual 133  
     before starting 123  
     depending on usage frequency 124  
     monthly 130  
 mechanical stabilizer feet 27  
 model overview 12, 14  
 monthly maintenance 130

## N

nuts check 132

## O

oil 125, 130  
 oil drain plug 134, 136  
 oil level check 130  
 one-hand control 38  
     easy move 62  
     hydraulic stabilizer feet 50  
 opening the platform 32  
 operating element  
     foot control 98  
     Hand cable control 100, 102, 105  
     lateral 38  
     special operating elements 110, 112, 114  
     two hand cable controls 92  
     wireless remote control unit (standard) 108  
 operating media 178

operator position. 125  
 overview  
     column lifts 21  
     foldable tail lifts 13, 20  
     retractable tail lifts 13, 18  
     retraction equipment 19  
     standard tail lift 14, 17  
     standard tail lifts 12

## P

payload 157  
 payload center of gravity 14, 125  
 platform 14  
     close 32, 34, 38  
     extend 32, 38  
     fold in 32, 34, 38  
     fold out 32, 33, 38  
     ground adjustment 32  
     lift 32, 34  
     load 34  
     lower 32, 33, 38  
     moving 31  
     open 32, 33, 38  
     platform tilt 32  
     position horizontally 32, 38  
     retract 32, 34, 38  
     unload 34  
 platform package 14  
 platform tilt 22, 33  
 presetting the tail lift 22  
 pushbutton 38

## Q

qualification of personnel 7

## R

refresh marks 125  
 retracting the platform 32  
 roll stop 14  
 roll-off protection bearings 126

rotary switch 38

## S

safety devices 123  
     checking 123  
 safety instructions 8  
 scope of delivery 11  
 service 120  
 Service counter 117  
 setting the platform tilt 33  
 setting the platform to its horizontal position 33  
 sliding console in the guide rails 127  
 spare parts 178  
 special operating elements 110, 112, 114  
 stabilizer feet  
     hydraulic 27, 44  
     mechanical 27  
 standard wireless remote control unit 108  
 stationary part of platform 14  
 suction filter 134, 136  
 support tube 14  
 supporting strap on body 14  
 Switch in driver's cab 25, 36

## T

Tail lift 32  
     close 32, 34  
     extend 32, 33  
     fold in 32, 34  
     fold out 32, 33  
     ground adjustment 32  
     lift 32, 34  
     load 34  
     lower 32, 33  
     moving 31  
     open 32, 33  
     platform tilt 32  
     position horizontally 32  
     presetting 22

retract 32, 34  
 switch off 36  
 switching on 25  
 unload 34

## tail lift

close 38  
 extend 38  
 fold in 38  
 fold out 38  
 lower 38  
 open 38  
 position horizontally 38  
 retract 38

tail lift models 12, 14  
 technical data 156  
 temperature range 156  
 tilt cylinder 14  
 tilt sensor 14  
 toggle switch 38  
 torsion frame 14  
 troubleshooting 117  
 two hand cable controls 92  
 two-hand control 38  
     easy move 58  
     hydraulic stabilizer feet 44, 46  
     pushbuttons 54

## U

underrun bumper 14

## V

valve block 134, 136

## W

warning devices 123  
 warning lights 14  
 wireless remote control unit 108

**PALFINGER Tail Lifts GmbH**

Fockestraße 53  
D-27777 Ganderkesee/Hoykenkamp  
Tel.: +49-4221 8530  
Fax: +49-4221 87536  
infombb@palfinger.com  
www.palfinger.com

**PALFINGER Hayons S.A.S**

Rue de l'Eglise  
F-61310 Silly en Gouffern  
Tel.: +33-2 33 12 44 00  
Fax: +33-2 33 12 44 01  
francembb@palfinger.com  
www.palfinger.com

**PALFINGER Tail Lifts s.r.o.**

Gogolova 18  
SK-85101 Bratislava  
Tel.: +421-252 636 611  
Fax: +421-252 636 612  
mbbsk@palfinger.com  
www.palfinger.com

**PALFINGER Tail Lifts Ltd.**

Bessemer Road  
Welwyn Garden City  
UK-Herts AL7 1ET  
Tel.: +44-01707 325571  
Fax: +44-01707 327752  
inforatcliff@palfinger.com  
www.palfinger.com

**PALFINGER TAIL LIFTS**

**OPERATING INSTRUCTIONS**

**TAIL LIFTS**





# **Operating Instructions**

## **for**

### **PALFINGER Tail Lifts**

Standard Tail Lifts  
Retractable Tail Lifts  
Foldable Tail Lifts  
Column Lifts

# Table of Contents

<b>Table of Contents</b> .....	<b>4</b>
<b>About these Instructions</b> .....	<b>6</b>
Further Documentation .....	6
<b>Important Safety Information</b> .....	<b>7</b>
Proper Use .....	7
Qualification of Personnel .....	7
Safety Instructions in these Instructions .....	8
Observe the Following .....	8
<b>PALFINGER Tail Lifts– The Tail Lift</b> .....	<b>10</b>
<b>Scope of Delivery</b> .....	<b>11</b>
<b>How to Find Your Tail Lift Model</b> .....	<b>12</b>
<b>Model Overviews</b> .....	<b>14</b>
Standard Tail Lifts .....	14
Standard Tail Lifts .....	15
Standard Tail Lifts .....	16
Standard Tail Lifts with Electrical Cylinders .....	17
Retractable Tail Lifts .....	18
Retraction Equipment .....	19
Foldable Tail Lifts .....	20
Column Lifts .....	21
<b>Presetting the Tail Lift</b> .....	<b>22</b>
Setting the Ground Adjustment Timing .....	22
Presetting the Platform Tilt .....	22
Adjusting the pressure switch of the hydraulic stabilizer feet .....	23
<b>General Operation</b> .....	<b>24</b>
Switching on the Tail Lift .....	25
Extending the Stabilizer Feet at Your Vehicle .....	27
Retracting the Stabilizer Feet at Your Vehicle .....	28
Putting up or laying down the safety railing at the platform ..	28
Moving the Platform .....	31
Loading or Unloading the Platform .....	34
Switching off the Tail Lift .....	36
Driver's cab control unit .....	37

<b>Operating Elements .....</b>	<b>38</b>
Lateral Operating Element .....	38
Operation Using two Hand Cable Controls with three Pushbuttons, each .....	92
Optional Operating Method: Foot Control .....	98
Optional Operating Method: Hand Cable Control with two Pushbuttons .....	100
Optional Operating Method: Hand Cable Control with three Pushbuttons .....	102
Optional Operating Method: Hand Cable Control with four Pushbuttons for MBB C 750 SX .....	105
Optional Operating Method: Wireless Remote Control Unit (Standard) .....	108
Special Operating Elements .....	110
Special Operating Elements .....	112
Special Operating Elements .....	114
Programming a Key Code .....	116
<b>Service and Maintenance .....</b>	<b>120</b>
Maintenance Before Starting .....	123
Maintenance Depending on Usage Frequency .....	124
Monthly Maintenance .....	130
Quarterly or Semi-annual Maintenance .....	133
Annual Maintenance .....	133
Checks .....	138
<b>Eliminating Faults .....</b>	<b>139</b>
<b>Technical Data .....</b>	<b>156</b>
Load Diagrams .....	157
Hydraulic Diagrams .....	163
<b>Lubricants and Operating Media .....</b>	<b>178</b>
Recommended Hydraulic Oil Grades .....	178
Environment-friendly Oils .....	178
Recommended Lubricant Grease .....	178
<b>Available Accessories .....</b>	<b>178</b>
<b>Index .....</b>	<b>181</b>

## About these Instructions

These instructions contain important information to install, operate, and maintain the **PALFINGER Tail Lifts** tail lift in a safe and proper way, and to eliminate simple faults yourself.

- ▶ Before starting to work with the tail lift, read these instructions completely, particularly chapter „Important Safety Information“.

### Further Documentation

- Assembly instructions
- Assembly drawing
- Spare parts catalog (online)
- Test data booklet
- Assembly inspection report (on request)
- Brief operating instructions (optional)
- Supplement to operating instructions (optional)

## Important Safety Information

The **PALFINGER Tail Lifts** tail lift is manufactured according to state-of-the-art processes and approved safety standards. However, the risk of personal injuries and material damage exists if the following general safety instructions and the warnings prior to the work instructions given in this manual are not obeyed.

- ▶ Therefore, read these instructions thoroughly and completely before operating the tail lift.
- ▶ Store the instructions in such a way that all users have access to the instructions at any time.
- ▶ Always provide these operating instructions if you sell or rent out the vehicle with the tail lift.

## Proper Use

- ▶ Exclusively use the tail lift for loading and unloading goods. During loading and unloading, only the operator is allowed to travel on the lift.
- ▶ Observe all capacity limits as stated in the technical data. Proper use also means that you have read and understood these instructions, particularly chapter „Important Safety Information“.

Improper use is considered any use where the tail lift is used

- outside the application areas stated in these instructions,
- under operating conditions that deviate from the description in these instructions.

## Qualification of Personnel

The operation of the tail lift is only allowed for:

- personnel who has read and understood these instructions, particularly chapters „Important Safety Information“ and „General Operation“,
- and has been familiarized with mode of action and handling the tail lift.

## Safety Instructions in these Instructions

Safety instructions have been included before any instruction for actions where the risk of personal injuries or material damage exists.

Safety instructions are structured as follows:

### SIGNAL WORD



#### Description of type and source of hazard

Description of consequences if instructions are not observed

▶ Description of actions to eliminate the hazard

The described actions to eliminate the hazard must be absolutely complied with!

The signal word designates the severity of the hazard:

Signal word	Usage
<b>DANGER!</b>	<b>Indicates a direct</b> serious hazard that will result in severe injuries or even death, if the hazard is not avoided.
<b>WARNING!</b>	<b>Indicates a potential hazard that may result in severe injuries or even death, if the hazard is not avoided.</b>
<b>CAUTION!</b>	<b>Indicates a potentially hazardous situation that may result in medium or light injuries or damage to property if the hazard is not avoided.</b>

## Observe the Following

### General Notes



- Always have these instructions readily available in the vehicle.
- Constructional changes may only be performed by the contractor repair shop of **PALFINGER Tail Lifts**. You will find the address of your local contractor repair shop and other contact information in the list of repair shops.
- For maintenance, use only original **PALFINGER Tail Lifts** spare parts.
- Observe all applicable accident prevention regulations.

### When Switching On



- Before switching on the tail lift, check whether all safety and warning devices are in place and function properly.
  - Warning flags
  - Warning lights
  - Supporting straps
  - Roll stops

### During Operation



- Make sure that the tail lift is unlocked before taking it into operation.
- Provide sufficient illumination of the loading area.
- Never transport persons on the tail lift.
- Always load the tail lift in such a way that the weight is evenly distributed.
- Secure the load so that it cannot fall off the tail lift. Rolling containers without brakes may only be transported on the tail lift if you secure them with roll stops (roll-off protection) against rolling away.
- Keep the maneuvering area around the vehicle free.

### Prior to Maintenance



- Switch off the battery main switch or remove the grounding strap.
- Secure or relieve the springs before replacement.
- If hydraulic oil emerges, do not put your hands into the oil stream.
- When executing any maintenance work under the platform, secure the moving part against moving down.

### At Disposal



- Dispose of oils and filters according to the regulations in your country.

## PALFINGER Tail Lifts– The Tail Lift

Congratulations to the purchase of your new tail lift made by **PALFINGER Tail Lifts!**

With more than 50 years of experience in the field of hydraulic tail lifts, **PALFINGER Tail Lifts GmbH** is among the leading manufacturers of these highly helpful load systems.

You will encounter the tail lifts of the **PALFINGER Tail Lifts** brand and also former brands such as Hubfix, Interlift, and Hayons Inter in more than 40 countries throughout the world. More than 100,000 tail lifts manufactured in the factory near Bremen can be found on all five continents.

A unique service network with more than 2,500 service stations in Europe alone guarantees optimum logistics without borders. Your new **PALFINGER Tail Lifts** tail lift is features innovative and reliable technology. It was manufactured by our employees with great care. These are the best prerequisites for a long and problem-free service-life.

To familiarize yourself with the operation of the new tail lift, we ask you to read the following operating instructions carefully. In these instructions you also find the necessary safety instructions for the operation of the tail lift.

In case you have any questions concerning your tail lift, the **PALFINGER Tail Lifts** service team is readily available for you.

## Scope of Delivery

- Tail lift
- Adhesive label – ETMA information
- Large identification plate (for the platform)
- Small identification plate (for the lifting device)
- Underrun bumper shield (UBS)
- Load diagram
- Operating Instructions
- Test data booklet
- Starter kit, consists of:
  - Underrun bumper certificate
  - Assembly instructions
  - Brief operating instructions
  - Large inspection organization (TÜV) plate
  - Small inspection organization (TÜV) plate

# How to Find Your Tail Lift Model

Each tail lift model has been assigned a letter (**A** to **V**) in these operating instructions. You will find the letter at the beginning of each chapter that contains information concerning your tail lift model. The following overview indicates which letter is valid for your model.

## Standard Tail Lifts

### A

#### Lateral Operating Pane

MBB C 1000 S – C 3000 S

MBB C 1000 LD – C 2500 L

MBB C 1500 SZ – C 2500 SZ

MBB C 1500 SK – C 2500 SK

MBB C 750 SPLD SPRD –  
C 1000 SPL SPR

MBB C 750 LD – C 1000 L

MBB C 1000 ML – C 1500 ML

MBB C 1000 ML PRO –  
C 1500 ML PRO

MBB C 750 S

MBB C 750 LX

MBB C 750 SX

MBB C 500 LD – C 750 L

MBB C 750 SPL SPR

MBB C 1500 LX – C 2000 LX

MBB C 1000 SB – C 1500 LB

### B

#### One-Cylinder Model

MBB C 500 LG

### C

#### minifix

MBB C 350 VAN – C 500 VAN

### E

#### Electrical Cylinders

MBB C 1000 E

## Retractable Tail Lifts

### **F** Platform Single-Folded

MBB R 750 L – R 2500 S  
 MBB R 1500 L  
 MBB R 1500 L FLAT  
 MBB R 1500 SK – R 2000 LK  
 MBB R 1500 S TRAIL –  
 R 2000 L TRAIL  
 MBB R 1500 S TRUCK –  
 R 2000 L TRUCK  
 MBB R 1000 S TRUCK-LGD –  
 R 2000 L TRUCK-LGD  
 MBB R 1500 S TRAIL-LGD –  
 R 2500 L TRAIL-LGD

### **G** Platform Double-Folded

MBB R 1500 SH – R 2000 LH  
 MBB R 750 SM – R 2000 LM

## Foldable Tail Lifts

### **K** Four-Cylinder Model

MBB F 1000 SH – F 2000 LH  
 MBB F 1000 SX – F 1500 LX

### **L** Two-Cylinder Model

MBB F 1000 LD – F 1500 LU  
 MBB F 1000 L – F 1500 L

### **M** One-Cylinder Model

MBB F 500 L – F 600 L

## Column Lifts

### **V** Standard Column Lift

MBB V 4000 S

## Model Overviews

### A Standard Tail Lifts

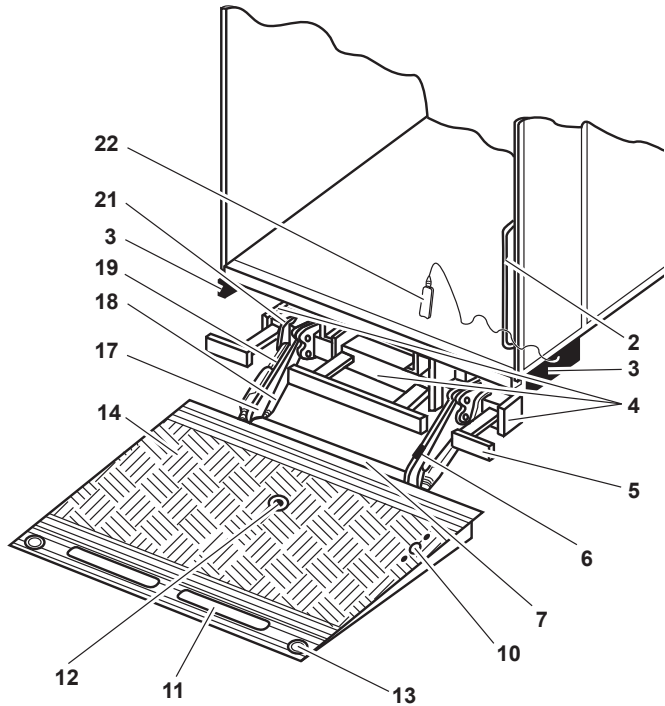

- |    |   |    |   |
|----|---|----|---|
| 2  | Supporting strap on body (not in scope of delivery) | 11 | Roll stop (roll-off protection, optional) |
| 3  | Lateral operating panel                             | 12 | Payload center of gravity                 |
| 4  | Hydraulic unit                                      | 13 | Warning lights (optional)                 |
| 5  | Underrun bumper                                     | 14 | Platform                                  |
| 6  | Lift arms switch b13, tilt sensor b15               | 17 | Torsion frame                             |
| 7  | Lift arms switch b16, tilt sensor b15               | 18 | Lift cylinder                             |
| 10 | Foot control  | 19 | Tilt cylinder                             |
|    |   | 21 | Support tube                              |
|    |   | 22 | Hand cable control                        |

## **B Standard Tail Lifts**

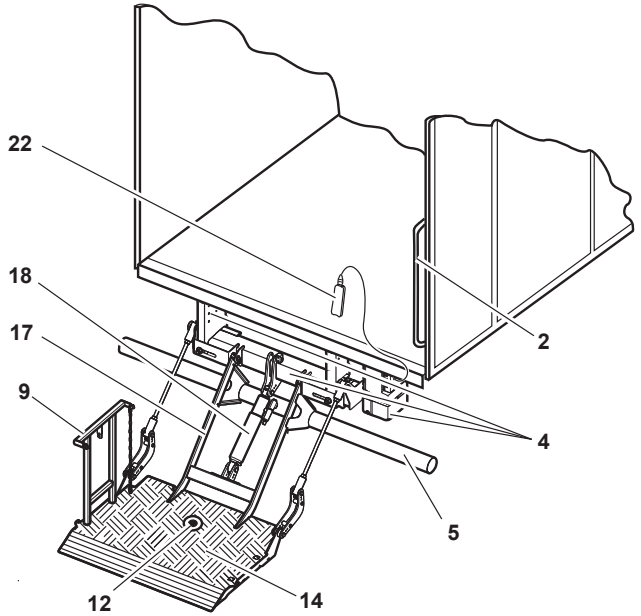

- |   |                                     |
|---|-------------------------------------|
| <b>2</b> Supporting strap on body<br>(not in scope of delivery) | <b>12</b> Payload center of gravity |
| <b>4</b> Hydraulic unit   | <b>14</b> Platform                  |
| <b>5</b> Underrun bumper  | <b>17</b> Torsion frame             |
| <b>9</b> Railing  | <b>18</b> Lift cylinder             |
|   | <b>22</b> Hand cable control        |

## C Standard Tail Lifts

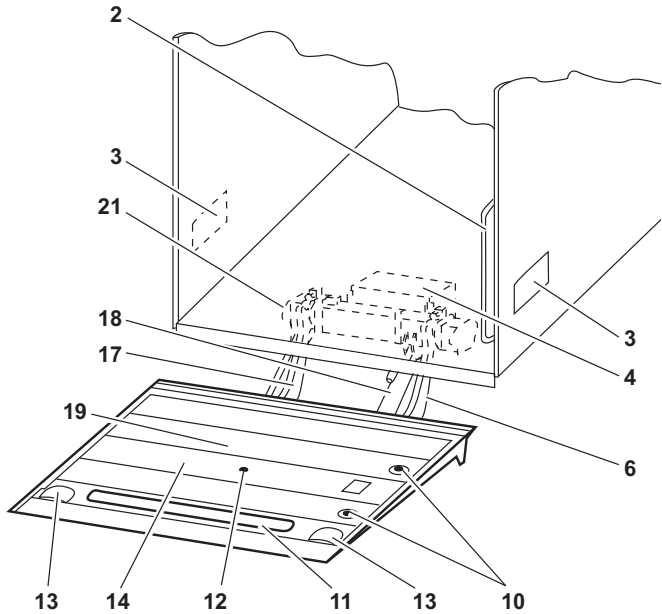

- |   |  |
|---|--|
| <b>2</b> Supporting strap on body<br>(not in scope of delivery) | <b>13</b> Warning lights<br>(optional)           |
| <b>3</b> Lateral operating panel                                | <b>14</b> Platform                               |
| <b>4</b> Hydraulic unit   | <b>17</b> Torsion frame                          |
| <b>6</b> Lift arms switch b13                                   | <b>18</b> Lift cylinder                          |
| <b>10</b> Foot control  | <b>19</b> Tilt cylinder (covered by<br>platform) |
| <b>11</b> Roll stop (roll-off protection,<br>optional)          | <b>21</b> Support tube                           |
| <b>12</b> Payload center of gravity                             |  |

## E Standard Tail Lifts with Electrical Cylinders

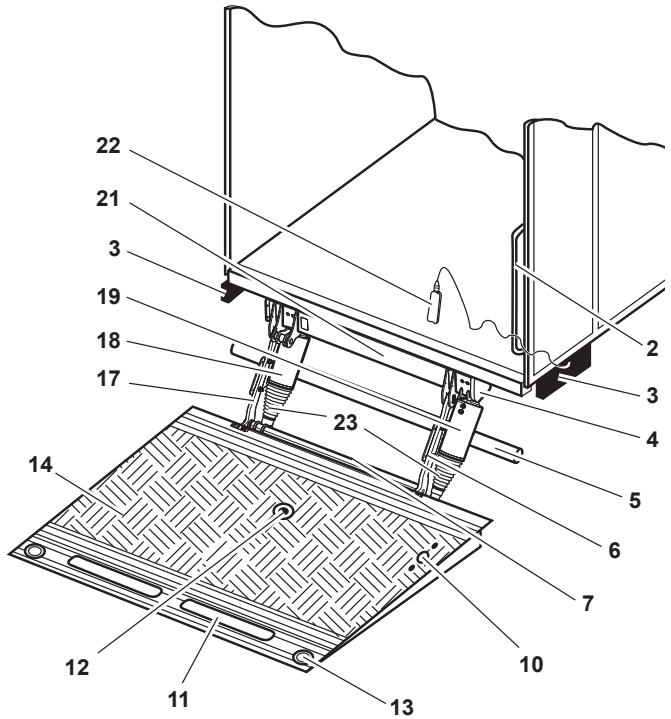

- |    |  |    |                           |
|----|--|----|---------------------------|
| 2  | Supporting strap on body<br>(not in scope of delivery) | 12 | Payload center of gravity |
| 3  | Lateral operating panel                                | 13 | Warning lights (optional) |
| 4  | Power unit   | 14 | Platform                  |
| 5  | Underrun bumper  | 17 | Torsion frame             |
| 6  | Tilt sensor b15  | 18 | Lift cylinder             |
| 7  | Tilt sensor b15  | 19 | Tilt cylinder             |
| 10 | Foot control   | 21 | Support tube              |
| 11 | Roll stop (roll-off<br>protection, optional)           | 22 | Hand cable control        |
|    |  | 23 | Bellows                   |

## FG Retractable Tail Lifts

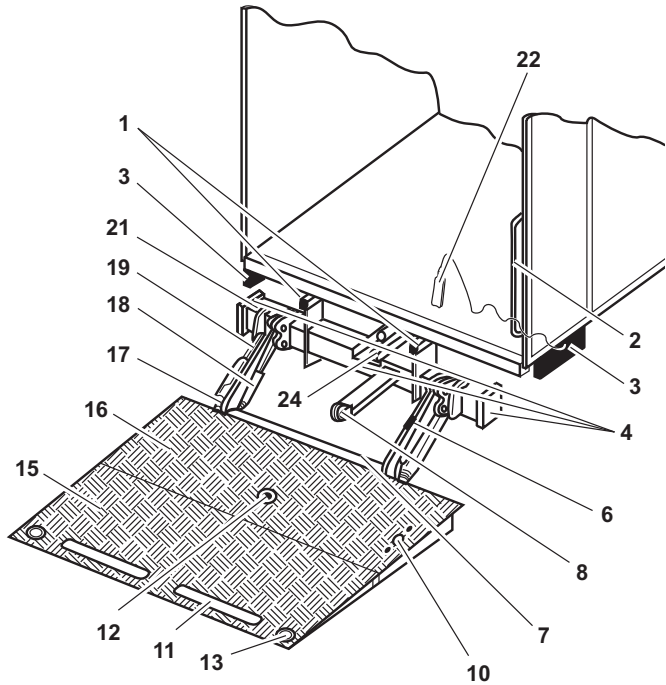

- |    |  |    |                             |
|----|--|----|-----------------------------|
| 1  | Guide rails  | 12 | Payload center of gravity   |
| 2  | Supporting strap on body<br>(not in scope of delivery) | 13 | Warning lights (optional)   |
| 3  | Lateral operating panel                                | 15 | Folding part of platform    |
| 4  | Hydraulic unit   | 16 | Stationary part of platform |
| 6  | Lift arms switch b13,<br>tilt sensor b15               | 17 | Torsion frame               |
| 7  | Lift arms switch b16,<br>tilt sensor b15               | 18 | Lift cylinder               |
| 8  | Guide pulley   | 19 | Tilt cylinder               |
| 10 | Foot control (optional)                                | 21 | Support tube                |
| 11 | Roll stop (roll-off<br>protection, optional)           | 22 | Hand cable control          |
|    |  | 24 | Guide cylinder              |

## Retraction Equipment

**F**

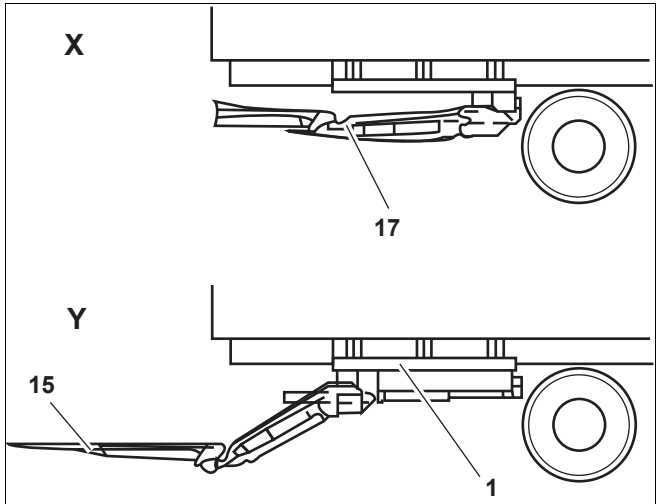

**G**

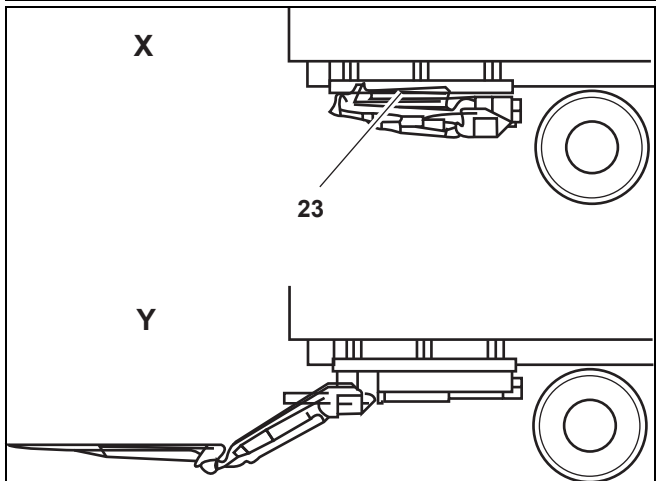

- 1 Guide rails
- 15 Folding part of platform
- 17 Torsion frame
- 23 Platform package

- X Transport position
- Y Operating position

## K L M Foldable Tail Lifts

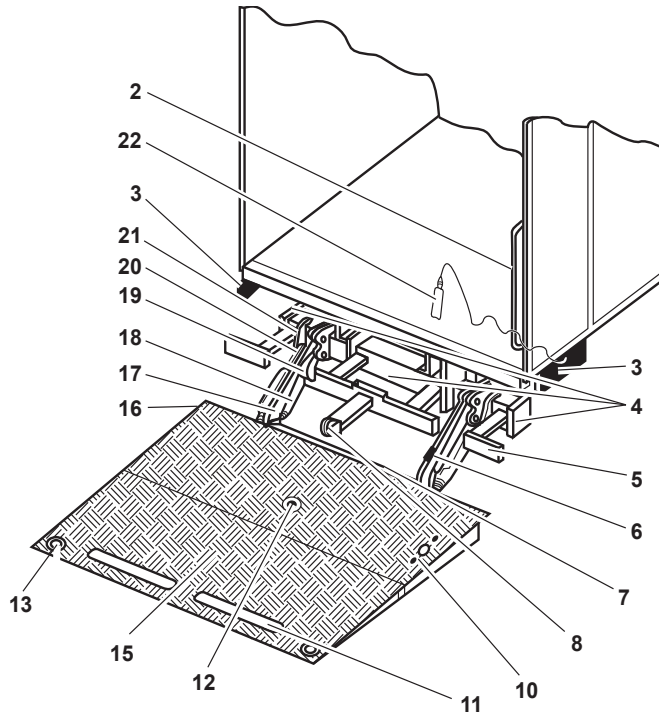

- |    |   |    |                             |
|----|---|----|-----------------------------|
| 2  | Supporting strap on body (not in scope of delivery) | 12 | Payload center of gravity   |
| 3  | Lateral operating panel                             | 13 | Warning lights (optional)   |
| 4  | Hydraulic unit                                      | 15 | Folding part of platform    |
| 5  | Underrun bumper                                     | 16 | Stationary part of platform |
| 6  | Lift arms switch b13, tilt sensor b15               | 17 | Torsion frame               |
| 7  | Lift arms switch b16, tilt sensor b15               | 18 | Lift cylinder               |
| 8  | Guide pulley  | 19 | Tilt cylinder               |
| 10 | Foot control (optional)                             | 20 | Roller at underrun bumper   |
| 11 | Roll stop (roll-off protection, optional)           | 21 | Support tube                |
|    |   | 22 | Hand cable control          |

## V Column Lifts

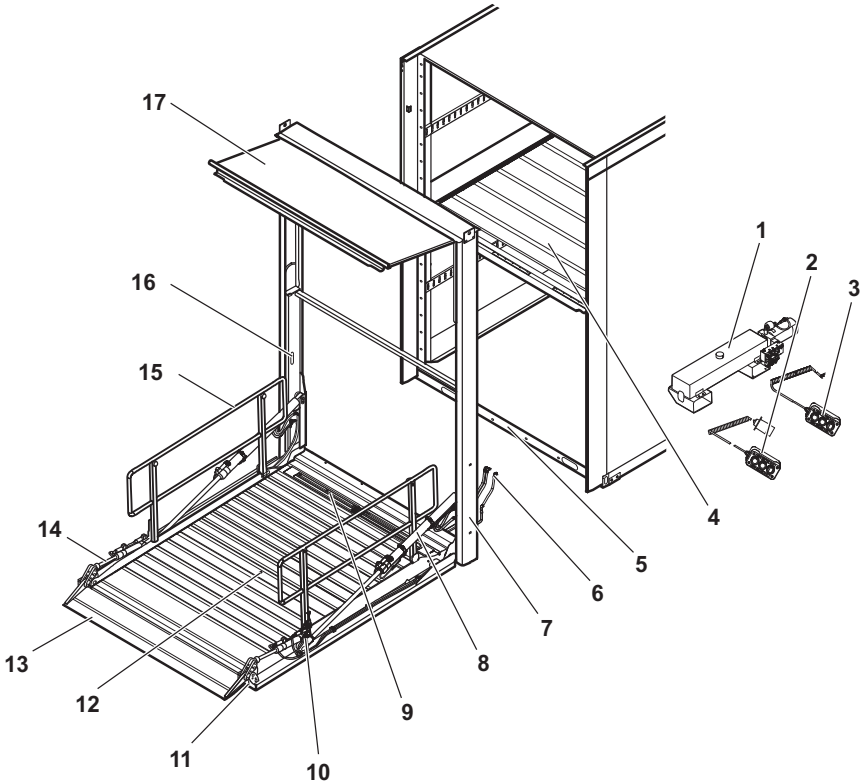

- |  |   |
|--|---|
| <b>1</b> Hydraulic unit with oil tank                  | <b>10</b> Tilt sensor b15 (factory-set, do not change position) |
| <b>2</b> Hand cable control 1                          | <b>11</b> Warning light   |
| <b>3</b> Hand cable control 2                          | <b>12</b> Payload center of gravity                             |
| <b>4</b> Vehicle deck 2                                | <b>13</b> Link bridge (roll stop, towards external side)        |
| <b>5</b> Vehicle deck 1                                | <b>14</b> Tilt cylinder   |
| <b>6</b> Hydraulic hoses (connected to hydraulic unit) | <b>15</b> Safety railing  |
| <b>7</b> Guide frame                                   | <b>16</b> Slide   |
| <b>8</b> Closing cylinder                              | <b>17</b> Top flap  |
| <b>9</b> Roll-stop, towards vehicle rear               |   |

## Presetting the Tail Lift

This chapter provides principle settings to enable the comfortable and safe use of the tail lift.

**A C F**

### Setting the Ground Adjustment Timing

Only for E-Type equipment with lift arms switch b13 the workshop can determine the time the platform initiates the tilt process (ground adjustment) after making contact with the ground.

To adjust the timing for the ground adjustment:

- ▶ Loosen the fastening screw at lift arms switch b13 (6).
- ▶ To set an „earlier“ ground adjustment, turn lift arms switch b13 (6) a few millimeters clockwise.  
To set a „later“ ground adjustment, turn lift arms switch b13 (6) a few millimeters counterclockwise.
- ▶ Retighten the fastening screw at lift arms switch b13 (6).
- ▶ Check whether the platform initiates the tilt process at the time desired.
- ▶ Check whether the spring washer is mounted between lift arms switch and screw and fold back the locking plate.

*The time the platform is supposed to tilt has been preset now. The platform tilts earlier or later.*

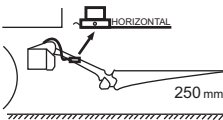
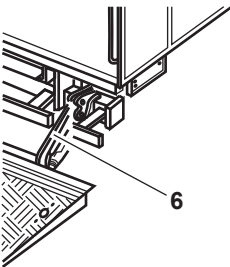

**A E F G K**

### Presetting the Platform Tilt

After the platform was lifted from the ground, it reverts to the preset position. You can adjust the tilt of the platform slightly higher or lower.

- ▶ Adjust the desired upper position using the “Open/Close” pushbuttons of the operating panel (see chapter “Operating Elements” from p. 38). This is only possible with the tilt sensor b15 on the platform.

## A Adjusting the pressure switch of the hydraulic stabilizer feet

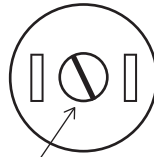

Turn set screw  
(adjustment range 20 to 50 bars)  
- clockwise to  
increase pressure  
- counterclockwise to  
reduce pressure

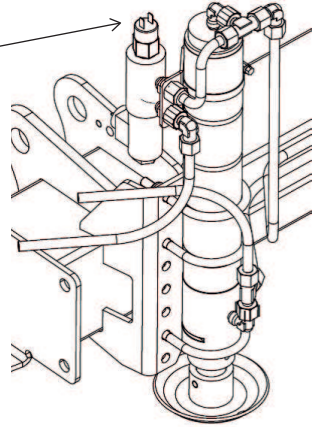

If the hydraulic stabilizer feet should lift the vehicle excessively or should not reach the ground, the pressure switch of the stabilizer can be adjusted.

For this purpose, turn the set screw on the pressure switch.

In order to reduce the contact pressure of the stabilizer feet, turn the set screw counterclockwise by one turn.

In order to increase the contact pressure of the stabilizer feet, turn the set screw clockwise by one turn.

After the adjustment, verify the contact pressure by lowering the stabilizer feet. If the stabilizer feet are not yet switched off as required, repeat the setting procedure.

## General Operation

This chapter provides basic information that you must observe during operation. This information applies to all tail lift models.

- ▶ Read the entire chapter carefully and pay special attention to the following safety instructions.

### CAUTION!



#### Hazard of battery discharge!

When the symbol shown on the left is depicted on the operating element of your tail lift, the tail lift is equipped with a battery monitoring system (BÜW).

When the battery capacity falls below the limit value, a buzzer is sounded and the tail lift is automatically switched off, to conserve battery power. The battery power is already at a low level that only one more engine start is possible. IF you continue to use the tail lift, you will not be able to start the vehicle!

- ▶ Start the vehicle engine immediately after hearing the buzzer, to recharge the battery!

**Note:** For more information on the recommended battery capacity refer to the corresponding table on p. 156.

## Switching on the Tail Lift

### CAUTION!



#### Risk of injury or material damage due to insufficient safety measures!

Personnel can be injured and material damage can occur at your vehicle, the tail lift, or other vehicles if you do not observe the following:

- ▶ Prior to starting work, be sure that all safety and warning devices are present and operational.
- ▶ Only stop in places where the traffic regulations permit a stop.
- ▶ Secure the vehicle against rolling away, for example by using the parking brake, engaging a gear, or wheel chocks.
- ▶ Secure the traffic area with warning flags and warning lights before loading or unloading the vehicle. Pay special attention to secure the operating elements of the tail lift that stick out into the moving traffic.

Depending on the model there are four ways to switch on the tail lift:

- Switch in driver's cab
- Key control at lateral operating element
- Key code at lateral operating element
- Battery main switch

To switch on the tail lift using the **switch** in the driver's cab:

- ▶ Set the switch in the driver's cab to "ON".

*The switch marking is no longer visible.*

*The operational readiness of the tail lift is shown by an optical signal in the driver's cab.*

*If the vehicle is equipped with a starter interlock, the vehicle cannot be started.*

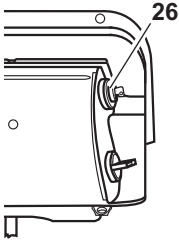

To switch on the tail lift using the **key control (26)** at the lateral operating element:

- ▶ Insert the key into the keyhole of the key control and turn it clockwise.

*The operational readiness of the tail lift is shown by an optical signal in the driver's cab.*

To switch on the tail lift using the **key code** at the lateral operating element:

- ▶ Enter the key code using the Lift and Close pushbuttons (see Chapter "Programming a Key Code" from p. 116").

*The operational readiness of the tail lift is shown by an optical signal in the driver's cab.*

To switch on the tail lift using the **battery main switch**:

- ▶ Turn the battery main switch clockwise until the cam is engaged.

*The operational readiness of the tail lift is shown by an optical signal in the driver's cab.*

## Extending the Stabilizer Feet at Your Vehicle

### CAUTION!



#### Damage to the vehicle!

The vehicle chassis frame can be damaged by insufficient carrying capacity of the ground or by incorrectly adjusted hydraulic stabilizer feet.

- ▶ Make sure that the carrying capacity of the ground is appropriate for the stabilizer feet!
- ▶ Never lift up the vehicle by means of the hydraulic stabilizer feet!
- ▶ Readjust the stabilizer feet several times while loading the vehicle.

### CAUTION!



#### Risk of injury or material damage for vehicles with air suspension

When you do not block the air suspension of your vehicle, the load is completely taken off the axles and the weight is transferred to the stabilizer feet. This can result in personal injuries and your tail lift, your vehicle, or the load can be damaged.

- ▶ Set the air suspension control lever of your vehicle to position "Block"!

#### Vehicles with Mechanical Stabilizer Feet

Mechanical stabilizer feet prevent chassis damage. When loading the vehicle, the stabilizer feet skid through.

To extend the mechanical stabilizer feet:

- ▶ Loosen the clamping device.
- ▶ Lower the stabilizer feet until they touch the ground.
- ▶ Hand-tighten the clamping device.

#### Vehicle with Hydraulic Stabilizer Feet

- ▶ To extend the hydraulic stabilizer feet, see "Operation Using Two-hand Control and Hydraulic Stabilizer Feet" from p. 44.

## Retracting the Stabilizer Feet at Your Vehicle

### Retracting Mechanical Stabilizer Feet

- ▶ Loosen the clamping device.
- ▶ Push the stabilizer feet back into the transport position.
- ▶ Hand-tighten the clamping device.

### Retracting Hydraulic Stabilizer Feet

#### CAUTION!



#### Risk of chassis damage!

In case of vehicles with air suspension, the entire weight can be shifted to the stabilizer feet.

- ▶ Before retracting the stabilizer feet, lift the vehicle by means of the air suspension in such a way that the stabilizer feet are relieved.
- ▶ To retract the hydraulic stabilizer feet, see “Operation Using Two-hand Control and Hydraulic Stabilizer Feet” from p. 44.

## Putting up or laying down the safety railing at the platform

Depending on the model, the platform of your tail lift is protected by a safety railing. There are two possible basic types of safety railings:

- a P-shaped safety railing
- an A-shaped safety railing

In order to put up or lay down the safety railings at the platform, proceed as described below:

### Putting up P-shaped safety railings

- ▶ Rotate the respective safety railing by 90° upwards, until it locks into place.

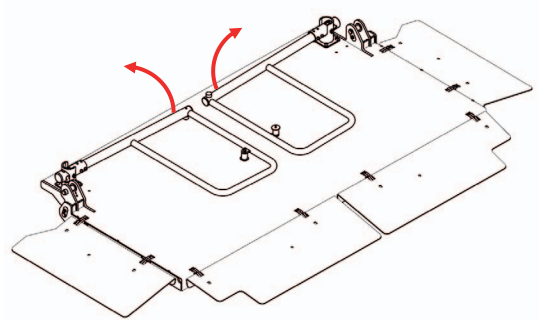

### Laying down P-shaped safety railings

- ▶ To unlock pull up the respective safety railing (1).
- ▶ Rotate the respective safety railing inwards (2), until the magnetic resilient pad touches down onto the platform.

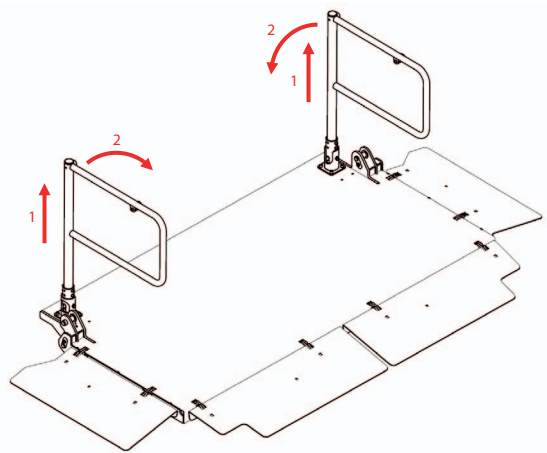

### Putting up A-shaped safety railing

- ▶ Pull the respective safety railing briefly towards the center of the platform (1).
- ▶ Rotate the respective safety railing by 90° upwards (2) and lower it until it locks into place.

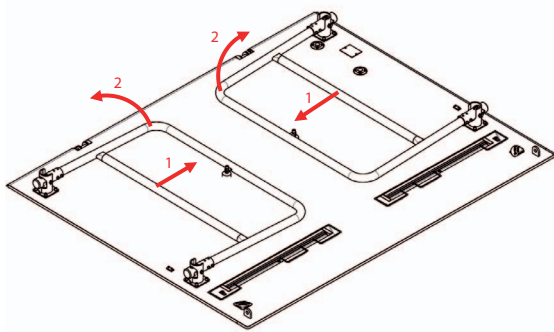

### Laying down A-shaped safety railing

- ▶ Pull up the respective safety railing (1).
- ▶ Then rotate the respective safety railing inwards (2), until the magnetic resilient pad touches down onto the platform.

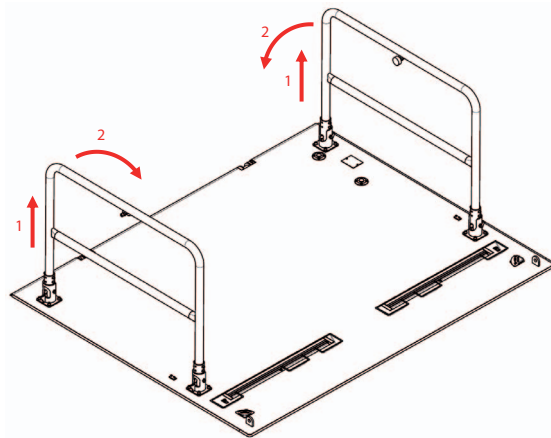

## Moving the Platform

### CAUTION!



#### **Risk of injury and material damage when moving the platform!**

Personnel can be injured when moving the platform. Vehicles and other object in the maneuvering area can be damaged. Load items can fall down and be damaged or injure other persons.

- ▶ Make sure that sufficient space is available behind the vehicle for the tail lift.
- ▶ Keep other persons away from the maneuvering area while you move the platform.
- ▶ Watch the payload, the maneuvering area, and the squeeze area to the vehicle while you move the platform.
- ▶ Observe that the operating element are only actuated to move the platform.
- ▶ Adjust the platform tilt only in no-load condition.

### CAUTION!



#### **Risk of injury because of insufficient holding or too little space on the platform!**

Persons can fall off the platform and suffer from injuries.

- ▶ When loading the platform, leave enough free space for the operator (minimum 50 x 60 cm).
- ▶ Only one person – the operator – is allowed to travel on the platform at any time.
- ▶ Never hold the payload, always hold tight to the supporting strap!
- ▶ Watch the payload and the maneuvering area while moving the platform.

How to move the platform depends on the model and the associated lateral operating element. For a detailed description refer to chapter “Operating Elements” from p. 38.

## Explanation of Terms

Actions for the platform:

- **Open**



The platform opens and moves from the vertical transport position to the desired operating position. This position is stored and reverted to when lifting the platform after the ground adjustment.

- **Close**



The platform closes and moves from the horizontal operating position to the vertical transport position.

- **Extend**

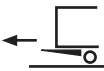

The platform extends from under the vehicle.

- **Retract**

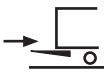

The platform retract under the vehicle.

- **Fold out**



The platform folds out from the transport position to the operating position.

- **Fold in**



The platform folds in from the operating position to the transport position.

- **Lower**



The platform moves in horizontal position downwards.

- **Lift**



The platform moves in horizontal position upwards.

• **Ground adjustment**



After bringing down the platform it tilts from the operating position to adjust to the ground level.

The foldable models **M** tilt gradually during bringing down the platform.

• **Setting the Platform to its Horizontal Position**



Before the platform is raised from the ground it tilts back into the horizontal operating position that was stored during opening.

The foldable models **M** tilt gradually during lifting to the horizontal operating position.

• **Set the platform tilt**



The platform can move to the desired operating position with a higher or lower tilt angle.

**Opening/Folding out/Extending the Platform and Setting the Platform Tilt**

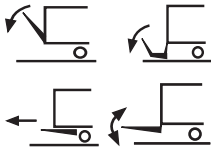

- ▶ Loosen the platform interlock (if present).
- ▶ Open, fold out or extend the tail lift depending on the model by means of the lateral operating element, the foot control, or the hand cable control, as described in chapter “Operating Elements” from p. 38 in this manual.
- ▶ Depending on the model, turn the rotary switch to open or close the platform, as described in chapter “Operating Elements” from p. 38 in this manual, until the unladen platform reaches the desired tilt angle.

**Bringing Down the Platform**



While the platform is brought down it remains in horizontal position. After the platform has touched the ground it tilts until the platform edge is flush with the ground.

- ▶ Lower the platform depending on the model by means of the lateral operating element, the foot control, or the hand cable control, as described in chapter “Operating Elements” from p. 38 in this manual.

*The platform is slowly brought down and automatically adjusts to the ground.*

## Lifting the Platform



Before the platform is lifted it tilts to the horizontal position. While the platform is lifted it remains in horizontal position.

- ▶ Lift the platform depending on the model by means of the lateral operating element, the foot control, or the hand cable control, as described in chapter "Operating Elements" from p. 38 in this manual.

## Closing/Folding In/Retracting the Platform

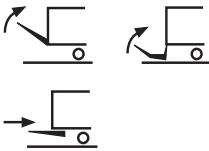

- ▶ Close, fold in or retract the platform depending on the model by means of the lateral operating element, the foot control, or the hand cable control, as described in chapter "Operating Elements" from p. 38 of this manual.
- ▶ Close the platform interlock (if present).

## Loading or Unloading the Platform

### CAUTION!



#### Damage to the tail lift by incorrect loading!

The tail lift can be damaged if the platform load is too high or unbalanced.

- ▶ Do not exceed the maximum load weight specified in chapter "Technical Data" from p. 156 of this manual when loading the platform. Take the weight of the operator standing on the platform into account. The load diagram is also shown at the lateral operating element.
- ▶ Center the load on the platform. The payload center of gravity should be as close to the vehicle as possible. If you load the platform on one side only, the payload weight may be max. 50% of the permitted payload.
- ▶ Rolling containers without brakes may only be loaded if the tail lift is equipped with a roll-off protection (roll stops or grooves). Rolling containers without brakes must always be secured by this roll-off protection.

### CAUTION!



#### Risk of injury!

Persons can fall off the platform and suffer from injuries.

- ▶ When loading the platform, leave enough free space for the operator (minimum 50 x 60 cm).

## Loading or Unloading the Platform on the Ground

- ▶ Roll or lift the payload onto the platform.
- ▶ Secure any rolling containers on the tail lift by installed brake devices or roll-off protections.

## Loading or Unloading the Platform at a Ramp

### CAUTION!



#### Risk of falling when loading at a ramp!

Person can trip and fall down if there is an edge between ramp and platform during loading or unloading.

- ▶ When the vehicle is unloaded and is lifted up by the spring action, lower the platform manually.

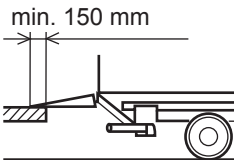
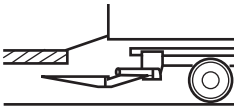

#### Note:

You can load your vehicle at a ramp in two possible ways:

1. You can use a separate dock plate. Make sure that sufficient space for tail lift exists under the ramp (see figure on the left)!
2. You can use the tail lift itself as dock plate at a ramp. Make sure that the platform edge overlaps the ramp at least 150 mm (see figure on the left).

The maximum permissible load must not be exceeded.

The tail lifts are equipped with a float mode. The float mode is a safety feature. When the vehicle lowers itself during loading, the float mode causes the platform to automatically yield and reposition itself. This does not apply to column lifts.

The float mode does not function during unloading. You must manually lower the platform. Thus you prevent a gap between platform and ramp where you could trip.

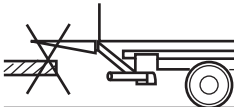
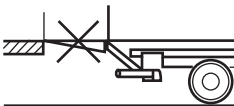

## Switching off the Tail Lift

The tail lift may only be switched off when the platform is closed and/or folded in.

### CAUTION!



#### Risk of injury or material damage due to unlocked tail lift!

Persons can be injured or vehicles and objects in public road traffic can be damaged if the tail lift folds out accidentally during driving and sticks out into the moving traffic.

- ▶ Before driving, lock the tail lift after folding in.
- ▶ Make sure that the warning lights **(25)** in the driver's cab are not lit.

Depending on the model, there are various different ways to switch off the tail lift:

- Switch in driver's cab
- Key control at lateral operating element
- Key code at lateral operating element
- Battery main switch
- Driver's cab control unit with camera system

To switch off the tail lift using the **switch** in the driver's cab:

- ▶ Set the switch at the control box in the driver's cab to "OFF".

*The visual signal indicating the operational readiness of the tail lift extinguishes. The tail lift is switched off.*

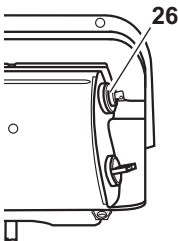

To switch off the tail lift using the **key control (26)** at the lateral operating element:

- ▶ Insert the key into the keyhole of the key control and turn it counterclockwise.
- ▶ Remove the key.

*The visual signal indicating the operational readiness of the tail lift extinguishes. The tail lift is switched off.*

To switch off the tail lift using the **key code** at the lateral operating element:

- ▶ Enter the key code using the Lift and Close pushbuttons (see Chapter “Programming a Key Code” from p. 116).

*The visual signal indicating the operational readiness of the tail lift extinguishes. The tail lift is switched off.*

To switch off the tail lift using the **battery main switch**:

- ▶ Turn the battery main switch counterclockwise until the cam is engaged.

*The visual signal indicating the operational readiness of the tail lift extinguishes. The tail lift is switched off.*

## Driver's cab control unit

- Note:** In case there is a driver's cab control unit with camera system, please observe the complement to the operating instructions which is added to the driver's cab control unit as a separate document.

# Operating Elements

This chapter describes the operating elements of the different tail lift models. To identify your model, refer to “How to Find Your Tail Lift Model”, p. 12.

## CAUTION!



### Risk of accidents and injury!

If the safety and warning devices of the tail lift are damaged or missing, personal injuries or material damage can occur.

- ▶ Ensure that all safety and warning devices are present and operational.

You can operate the tail lift in several possible ways:

1. using the lateral operating element (depending on the model, see p. 38 to p. 116),
2. using the joystick (see p. 52)
3. using the two manual cable switches (for column lift, see p. 92),
4. using the foot control (optional, see p. 98) or
5. using the hand cable control (optional, see p. 100) or
6. using the radio remote control unit (optional, see p. 108) or
7. using the special operating elements (optional, see p. 110).

## Lateral Operating Element

Depending on your tail lift model you find information about the operation of the lateral operating element on:

<b>A E</b>	p. 39 to p. 50
<b>A</b>	p. 52
<b>B</b>	p. 84 to p. 90
<b>C</b>	p. 54
<b>F</b>	p. 56 to p. 62
<b>G</b>	p. 68 to p. 76
<b>K</b>	p. 80 to p. 82
<b>L</b>	p. 84 to p. 86
<b>M</b>	p. 84 to p. 90

## A E Operation Using Two-hand Control

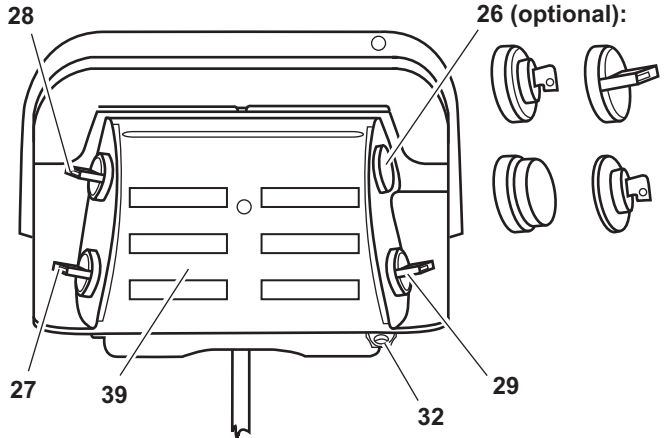

- 26 Optional: key control, rotary switch, emergency-off pushbutton, E30 key
- 27 Rotary switch: lift/lower
- 28 Rotary switch: open/close
- 29 Rotary switch: additional pushbutton
- 32 Locking lug
- 39 Operating panel

### DANGER!



#### Risk of accidents and injury!

If the instructions in chapter “General Operation” are not observed during operation of the tail lift, personal injuries and material damage can occur.

- Before operating the tail lift, read chapter “General Operation” from p. 24.

### Opening the Platform



- ▶ Loosen the platform interlock (if present).
- ▶ Turn the rotary switches **(28)** and **(29)** simultaneously downward and hold them down until the platform has reached the horizontal operating position.

*If an optional load safety device is present, the platform is lowered a small amount and then unfolds to the horizontal operating position.*

### Lowering the Platform



- ▶ Turn the rotary switches **(27)** and **(29)** simultaneously downward and hold them in this position until the platform has made contact with the ground.

*After the platform has touched the ground it tilts and adjusts to the ground.*

### Lifting the Platform



- ▶ Turn the rotary switches **(27)** and **(29)** simultaneously upward and hold them in this position until the platform has reached the vehicle loading floor height.

*The platform tilts to the horizontal or preset position before it is lifted.*

### Closing the Platform



- ▶ Turn the rotary switches **(28)** and **(29)** simultaneously upward and hold them in this position until the platform is closed.

*If an optional load safety device is present, the platform closes approximately to 80° and is lowered a small amount. Subsequently it moves to the vertical transport position and is lifted into the load safety device.*

- ▶ Close the platform interlock (if present).



## A Operation Using Two-hand Control without Automatic Ground Adjustment

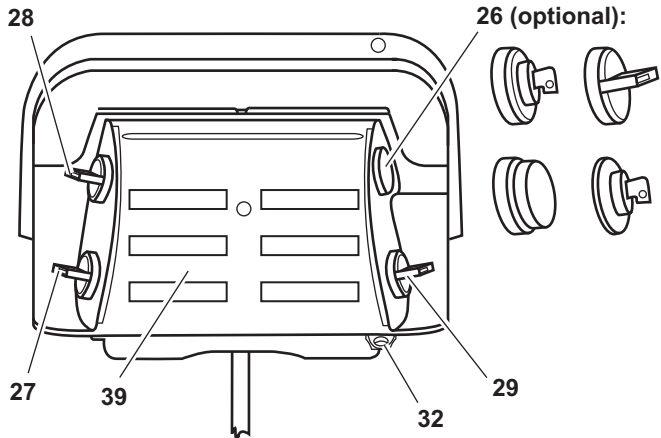

- 26** Optional: key control, rotary switch, emergency-off pushbutton, E30 key
- 27** Rotary switch: lift/lower
- 28** Rotary switch: open/close
- 29** Rotary switch: additional pushbutton
- 32** Locking lug
- 39** Operating panel

### DANGER!



#### Risk of accidents and injury!

If the instructions in chapter “General Operation” are not observed during operation of the tail lift, personal injuries and material damage can occur.

- ▶ Before operating the tail lift, read chapter “General Operation” from p. 24.

### Opening the Platform



- ▶ Loosen the platform interlock (if present).
- ▶ Turn the rotary switches (28) and (29) simultaneously downward and hold them down until the platform has reached the horizontal operating position.

### Lowering the Platform



- ▶ Turn the rotary switches (27) and (29) simultaneously downward and hold them in this position until the platform has reached the ground.

### Ground Adjustment



After the platform has touched the ground:

- ▶ Turn the rotary switches (28) and (29) simultaneously downward.

*The platform tilts and adjusts flush to the ground.*

### Setting the Platform to its Horizontal Position



- ▶ Turn the rotary switches (28) and (29) simultaneously upward and hold them in this position until the platform has reached the horizontal position.

### Lifting the Platform



- ▶ Turn the rotary switches (27) and (29) simultaneously upward and hold them in this position until the platform has reached the vehicle loading floor height.

### Closing the Platform



- ▶ Turn the rotary switches (28) and (29) simultaneously upward and hold them in this position until the platform is closed.

*The platform moves to the vertical transport position.*

- ▶ Close the platform interlock (if present).

## A Operation Using Two-hand Control and Hydraulic Stabilizer Feet

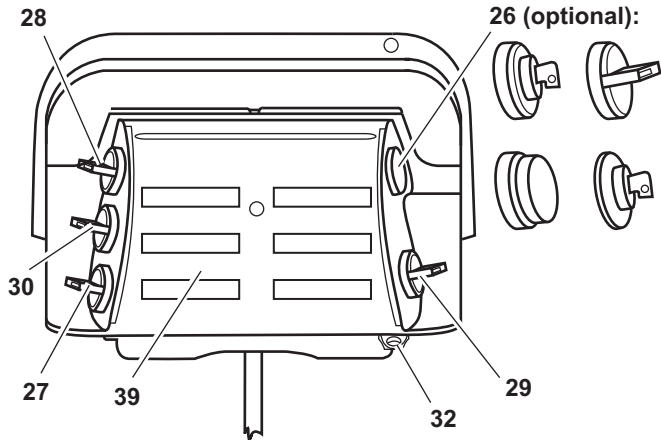

- 26** Optional: key control, rotary switch, emergency-off pushbutton, E30 key
- 27** Rotary switch: lift/lower
- 28** Rotary switch: open/close
- 29** Rotary switch: additional pushbutton
- 30** Rotary switch: retract and extend
- 32** Locking lug
- 39** Operating panel

### DANGER!



#### Risk of accidents and injury!

If the instructions in chapter “General Operation” are not observed during operation of the tail lift, personal injuries and material damage can occur.

- ▶ Before operating the tail lift, read chapter “General Operation” from p. 24.

#### Extending the Hydraulic Stabilizer Feet

- ▶ Turn the rotary switch **(30)** downward until the stabilizer feet are extended almost to the ground.

### Opening the Platform



- ▶ Loosen the platform interlock (if present).
- ▶ Turn the rotary switches **(27)** and **(29)** simultaneously downward and hold them down until the platform has reached the horizontal operating position.

*If an optional load safety device is present, the platform is lowered and then unfolds to the horizontal operating position.*

### Lowering the Platform



- ▶ Turn the rotary switches **(27)** and **(29)** simultaneously downward and hold them in this position until the platform has made contact with the ground.

*After the platform has touched the ground it tilts and adjusts to the ground.*

### Lifting the Platform



- ▶ Turn the rotary switches **(27)** and **(29)** simultaneously upward and hold them in this position until the platform has reached the vehicle loading floor height.

*The platform tilts to the horizontal or preset position before it is lifted.*

### Closing the Platform



- ▶ Turn the rotary switches **(28)** and **(29)** simultaneously upward and hold them in this position until the platform is closed.

*If an optional load safety device is present, the platform closes approximately to 80° and is lowered a small amount. Finally, it moves to the vertical transport position and is lifted into the load safety device.*

- ▶ Close the platform interlock (if present).

### Retracting the Hydraulic Stabilizer Feet

- ▶ Turn the rotary switch **(30)** upward until the stabilizer feet are completely retracted.

## A Operation Using Two-hand Control with a Hydraulic Underrun Bumper

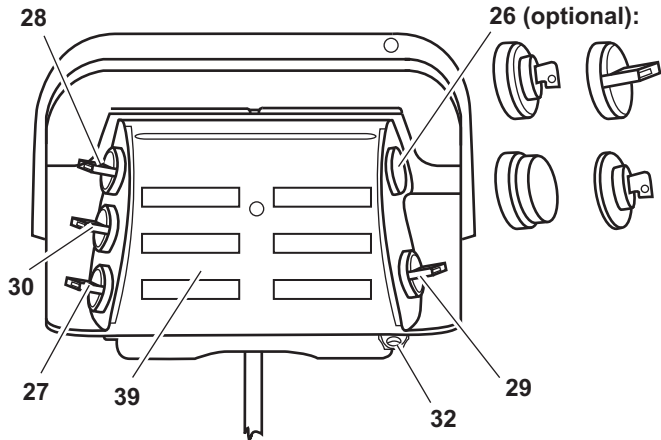

- 26 Optional: key control, rotary switch, emergency-off pushbutton, E30 key
- 27 Rotary switch: lift/lower
- 28 Rotary switch: open/close
- 29 Rotary switch: additional pushbutton
- 30 Rotary switch: lift/lower the underrun bumper
- 32 Locking lug
- 39 Operating panel

### DANGER!



#### Risk of accidents and injury!

If the instructions in chapter “General Operation” are not observed during operation of the tail lift, personal injuries and material damage can occur.

- ▶ Before operating the tail lift, read chapter “General Operation” from p. 24.

#### Lifting the Hydraulic Underrun Bumper

- ▶ Turn the rotary switch (30) upwards until the underrun bumper has reached its upper end position.

### Opening the Platform



- ▶ Loosen the platform interlock (if present).
- ▶ Turn the rotary switches **(27)** and **(29)** simultaneously downward and hold them down until the platform has reached the horizontal operating position.

*If an optional load safety device is present, the platform is lowered and then unfolds to the horizontal operating position.*

### Lowering the Platform



- ▶ Turn the rotary switches **(27)** and **(29)** simultaneously downward and hold them in this position until the platform has made contact with the ground.

*After the platform has touched the ground it tilts and adjusts to the ground.*

### Lifting the Platform



- ▶ Turn the rotary switches **(27)** and **(29)** simultaneously upward and hold them in this position until the platform has reached the vehicle loading floor height.

*The platform tilts to the horizontal or preset position before it is lifted.*

### Closing the Platform



- ▶ Turn the rotary switches **(28)** and **(29)** simultaneously upward and hold them in this position until the platform is closed.

*If an optional load safety device is present, the platform closes approximately to 80° and is lowered a small amount. Finally, it moves to the vertical transport position and is lifted into the load safety device.*

- ▶ Close the platform interlock (if present).

### Lowering the Hydraulic Underrun Bumper

- ▶ Turn the rotary switch **(30)** downwards until the underrun bumper has reached its lower end position.

## A E Operation Using One-hand Control

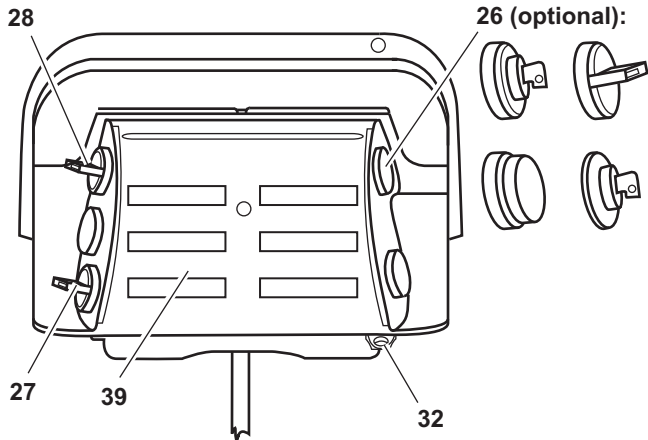

**26** Optional: key control, rotary switch, emergency-off pushbutton, E30 key

**27** Rotary switch: lift/lower

**28** Rotary switch: open/close

**32** Locking lug

**39** Operating panel

### DANGER!



#### Risk of accidents and injury!

If the instructions in chapter “General Operation” are not observed during operation of the tail lift, personal injuries and material damage can occur.

- ▶ Before operating the tail lift, read chapter “General Operation” from p. 24.

### Opening the Platform



- ▶ Loosen the platform interlock (if present).
- ▶ Turn the rotary switch **(28)** downward and hold it in this position until the platform has reached the horizontal operating position.

*If an optional load safety device is present, the platform is lowered and then unfolds to the horizontal operating position.*

### Lowering the Platform



- ▶ Turn the rotary switch **(27)** upward and hold it in this position until the platform is adjusted flush to the ground.

*After the platform has touched the ground it tilts and adjusts to the ground.*

### Lifting the Platform



- ▶ Turn the rotary switch **(27)** upward and hold it in this position until the platform has reached the vehicle loading floor height.

*The platform tilts to the horizontal or preset position before it is lifted.*

### Closing the Platform



- ▶ Turn the rotary switch **(28)** upward and hold it in this position until the platform is closed.

*If an optional load safety device is present, the platform closes approximately to 80° and is lowered a small amount. Finally, it moves to the vertical transport position and is lifted into the load safety device.*

- ▶ Close the platform interlock (if present).

## A Operation Using One-hand Control and Hydraulic Stabilizer Feet

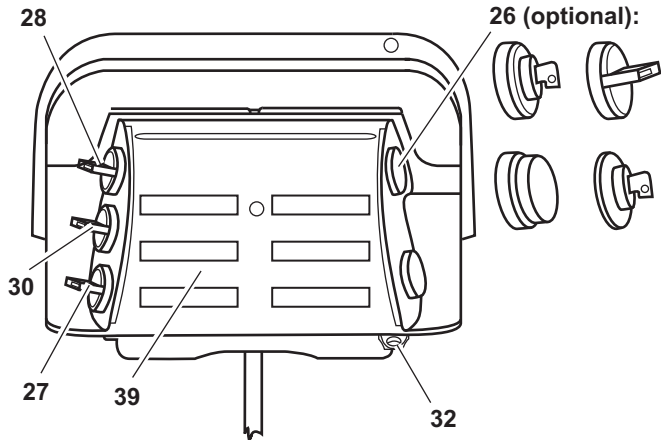

- 26** Optional: key control, rotary switch, emergency-off pushbutton, E30 key
- 27** Rotary switch: lift/lower
- 28** Rotary switch: open/close
- 30** Rotary switch: retract and extend
- 32** Locking lug
- 39** Operating panel

### DANGER!



#### Risk of accidents and injury!

If the instructions in chapter “General Operation” are not observed during operation of the tail lift, personal injuries and material damage can occur.

- ▶ Before operating the tail lift, read chapter “General Operation” from p. 24.

#### Extending the Hydraulic Stabilizer Feet

- ▶ Turn the rotary switch **(30)** downward until the stabilizer feet are extended almost to the ground.

### Opening the Platform



- ▶ Loosen the platform interlock (if present).
- ▶ Turn the rotary switch **(28)** downward and hold it in this position until the platform has reached the horizontal operating position.

*If an optional load safety device is present, the platform is lowered and then unfolds to the horizontal operating position.*

### Lowering the Platform



- ▶ Turn the rotary switch **(27)** upward and hold it in this position until the platform is adjusted flush to the ground.

*After the platform has touched the ground it tilts and adjusts to the ground.*

### Lifting the Platform



- ▶ Turn the rotary switch **(27)** upward and hold it in this position until the platform has reached the vehicle loading floor height.

*The platform tilts to the horizontal or preset position before it is lifted.*

### Closing the Platform



- ▶ Turn the rotary switch **(28)** upward and hold it in this position until the platform is closed.

*If an optional load safety device is present, the platform closes approximately to 80° and is lowered a small amount. Finally, it moves to the vertical transport position and is lifted into the load safety device.*

- ▶ Close the platform interlock (if present).

### Retracting the Hydraulic Stabilizer Feet

- ▶ Turn the rotary switch **(30)** upward until the stabilizer feet are completely retracted.

## A Operation Using Joystick

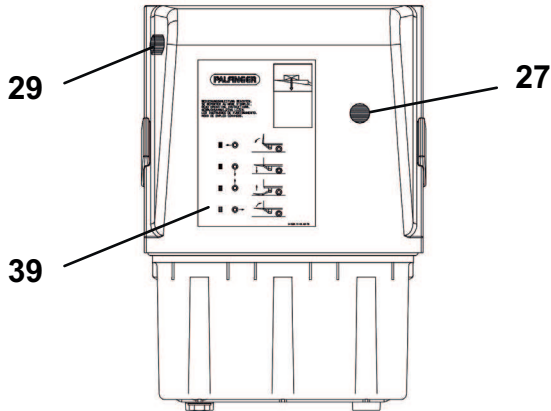

- 27 Joystick: lift/lower/open/close
- 29 Pushbutton: additional pushbutton
- 39 Operating panel

### DANGER!



#### Risk of accidents and injury!

If the instructions in chapter “General Operation” are not observed during operation of the tail lift, personal injuries and material damage can occur.

- ▶ Before operating the tail lift, read chapter “General Operation” from p. 24.

### Opening the Platform



- ▶ Loosen the platform interlock (if present).
- ▶ Press the pushbutton **(29)** and simultaneously move the joystick **(27)** to the left (direction of travel right) or to the right (direction of travel left) and hold them in this position until the platform has reached the horizontal operating position.

### Lowering the Platform



- ▶ Press the pushbutton **(29)** and simultaneously move the joystick downward and hold them in this position until the platform is adjusted flush to the ground.

*After the platform has touched the ground it tilts and adjusts to the ground.*

### Lifting the Platform



- ▶ Press the pushbutton **(29)** and simultaneously move the joystick **(27)** upward and hold them in this position until the platform has reached the vehicle loading floor height.

*The platform tilts to the horizontal or preset position before it is lifted.*

### Closing the Platform



- ▶ Press the pushbutton **(29)** and simultaneously move the joystick **(27)** to the right (direction of travel right) or to the left (direction of travel left) and hold them in this position until the platform is completely closed.
- ▶ Close the platform interlock (if present).

## C Operation Using Two-hand Control and Pushbuttons

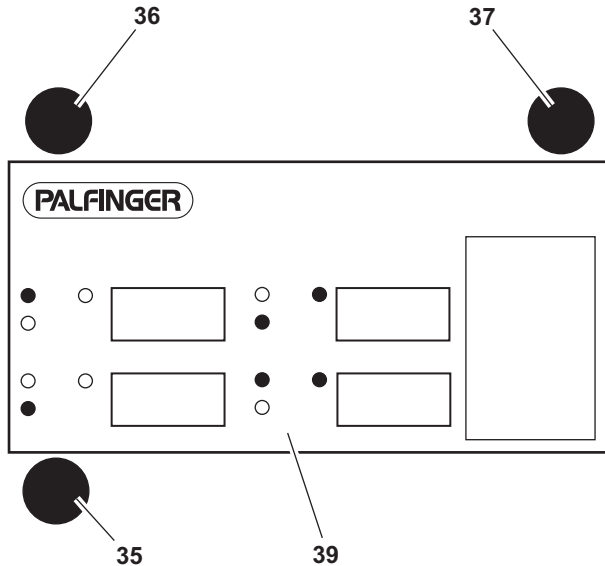

- 35** Pushbutton: lower/lift
- 36** Pushbutton: open/close
- 37** Pushbutton: lift/close
- 39** Operating panel

### DANGER!



#### Risk of accidents and injury!

If the instructions in chapter “General Operation” are not observed during operation of the tail lift, personal injuries and material damage can occur.

- ▶ Before operating the tail lift, read chapter “General Operation” from p. 24.

### Opening the Platform



- ▶ Loosen the platform interlock (if present).
- ▶ Press and hold pushbutton **(36)** until the platform has reached the horizontal operating position.

### Lowering the Platform



- ▶ Press and hold pushbutton **(35)** until the platform has made contact with the ground.

*After the platform has touched the ground it tilts and adjusts to the ground.*

### Lifting the Platform



- ▶ Press and hold pushbuttons **(35)** and **(37)** simultaneously until the platform has reached the vehicle loading floor height.

*The platform tilts to the horizontal or preset position before it is lifted.*

### Closing the Platform



- ▶ Press and hold pushbuttons **(36)** and **(37)** simultaneously until the platform has reached the vertical transport position.
- ▶ Close the platform interlock (if present).

## F Operation Using Two-hand Control

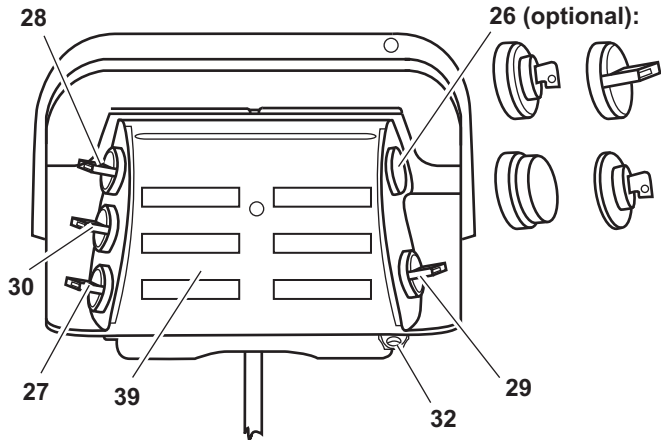

- 26** Optional: key control, rotary switch, emergency-off pushbutton, E30 key
- 27** Rotary switch: lift/lower
- 28** Rotary switch: open/close
- 29** Rotary switch: additional pushbutton
- 30** Rotary switch: Retract and extend
- 32** Locking lug
- 39** Operating panel

### DANGER!



#### Risk of accidents and injury!

If the instructions in chapter "General Information" are not observed during operation of the tail lift, personal injuries and material damage can occur.

- ▶ Before operating the tail lift, read chapter "General Operation" from p. 24.

#### Extending and Folding Out the Platform

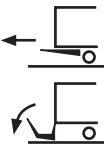

- ▶ Loosen the platform interlock (if present).
- ▶ Turn the rotary switches **(27)** and **(29)** simultaneously downward and hold them in this position until the platform has been lowered.

*The platform is lowered so that it can be extended without obstruction.*

- ▶ Turn the rotary switch **(30)** downward and hold it in this position until the platform is completely extended.
- ▶ Turn the rotary switches **(27)** and **(29)** simultaneously downward and hold them in this position until the folded platform has made contact with the ground.
- ▶ Protect your hands with gloves.
- ▶ Pull the handle with both hands to unfold the folding part of the platform.

### Lowering the Platform



- ▶ Turn the rotary switches **(27)** and **(29)** simultaneously downward and hold them in this position until the platform has made contact with the ground and is adjusted flush to the ground.

*After the platform has touched the ground it tilts and adjusts to the ground.*

### Lifting the Platform



- ▶ Turn the rotary switches **(27)** and **(29)** simultaneously upward and hold them in this position until the platform has reached the vehicle loading floor height.

*The platform tilts to the horizontal or preset position before it is lifted into the loading position.*

### Folding In and Retracting the Platform

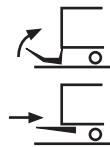

- ▶ Protect your hands with gloves.
- ▶ Pull the handle with both hands to fold back the folding part of the platform.
- ▶ Close the platform interlock (if present).
- ▶ Turn the rotary switches **(27)** and **(29)** simultaneously upward and hold them in this position until the platform has reached the retraction height.
- ▶ Turn the rotary switch **(30)** upward and hold it in this position until the platform is completely retracted. Observe that the platform can be retracted without obstruction.
- ▶ Turn the rotary switches **(27)** and **(29)** simultaneously upward and hold them in this position until the platform has reached the vibration safeguard.

## F Operation with Two-hand Control easy move®

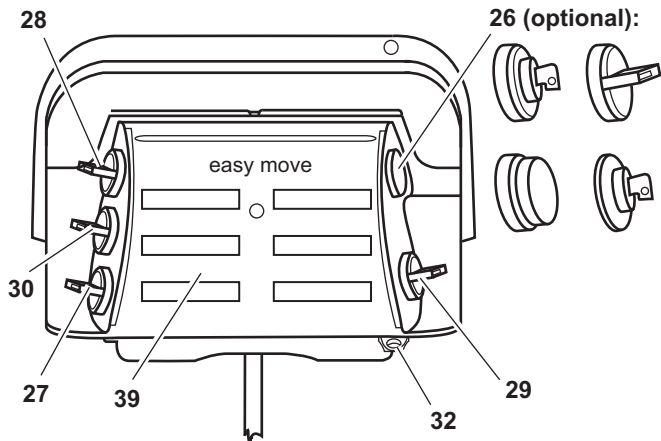

- 26 Optional: key control, rotary switch, emergency-off pushbutton, E30 key
- 27 Rotary switch: lift/lower
- 28 Rotary switch: open/close
- 29 Rotary switch: additional pushbutton
- 30 Rotary switch: Retract and extend
- 32 Locking lug
- 39 Operating panel

### DANGER!



#### Risk of accidents and injury!

If the instructions in chapter "General Information" are not observed during operation of the tail lift, personal injuries and material damage can occur.

- ▶ Before operating the tail lift, read chapter "General Operation" from p. 24.

#### Extending and Folding Out the Platform

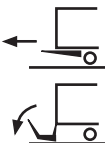

- ▶ Loosen the platform interlock (if present).
- ▶ Turn the rotary switch (30) downward and hold it in this position until the platform is extended.

*The platform is lowered so that it can be extended without obstruction and is extended.*

- ▶ Turn the rotary switches **(27)** and **(29)** simultaneously downward and hold them in this position until the folded platform has made contact with the ground.
- ▶ Protect your hands with gloves.
- ▶ Pull the handle with both hands to unfold the folding part of the platform.

### Lowering the Platform



- ▶ Turn the rotary switches **(27)** and **(29)** simultaneously downward and hold them in this position until the platform has made contact with the ground and is adjusted flush to the ground.

*After the platform has touched the ground it tilts and adjusts to the ground.*

### Lifting the Platform



- ▶ Turn the rotary switches **(27)** and **(29)** simultaneously upward and hold them in this position until the platform has reached the vehicle loading floor height.

*The platform tilts to the horizontal or preset position before it is lifted into the loading position.*

### Folding In and Retracting the Platform

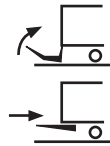

- ▶ Protect your hands with gloves.
- ▶ Pull the handle with both hands to fold back the folding part of the platform.
- ▶ Turn the rotary switch **(30)** upward and hold it in this position until the platform is completely retracted. Observe that the platform can be retracted without obstruction.

*The folded platform lifts or lowers automatically until the optimum retraction position is reached. The platform then retracts until the end position and lifts into the vibration safeguard.*

- ▶ Close the platform interlock (if present).

## F Operation with One-hand Control

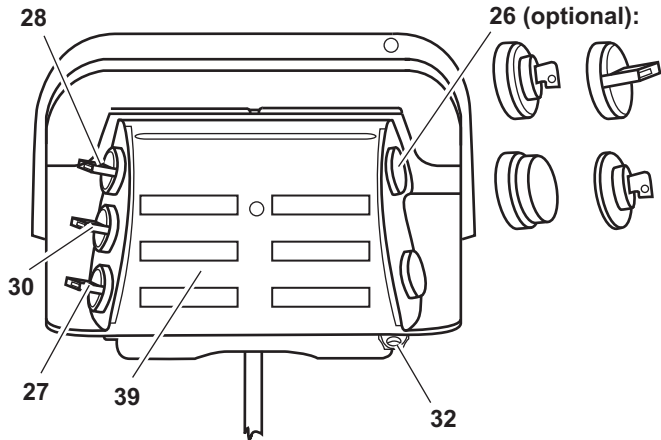

- 26** Optional: key control, rotary switch, emergency-off pushbutton, E30 key
- 27** Rotary switch: lift/lower
- 28** Rotary switch: open/close
- 30** Rotary switch: Retract and extend
- 32** Locking lug
- 39** Operating panel

### DANGER!



#### Risk of accidents and injury!

If the instructions in chapter "General Information" are not observed during operation of the tail lift, personal injuries and material damage can occur.

- ▶ Before operating the tail lift, read chapter "General Operation" from p. 24.

#### Extending and Folding Out the Platform

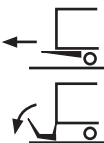

- ▶ Loosen the platform interlock (if present).
- ▶ Turn the rotary switch (**27**) downward and hold it in this position until the platform has been lowered.

*The platform is lowered so that it can be extended without obstruction.*

- ▶ Turn the rotary switch **(30)** downward and hold it in this position until the platform is completely extended.
- ▶ Turn the rotary switch **(27)** downward and hold it in this position until the folded platform has touched the ground.
- ▶ Protect your hands with gloves.
- ▶ Pull the handle with both hands to unfold the folding part of the platform.

### Lowering the Platform



- ▶ Turn the rotary switch **(27)** downward and hold it in this position until the platform has made contact with the ground and is adjusted flush to the ground.

*After the platform has touched the ground it tilts and adjusts to the ground.*

### Lifting the Platform



- ▶ Turn the rotary switch **(27)** upward and hold it in this position until the platform has reached the vehicle loading floor height.

*The platform tilts to the horizontal or preset position before it is lifted into the loading position.*

### Folding In and Retracting the Platform

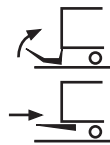

- ▶ Protect your hands with gloves.
- ▶ Pull the handle with both hands to fold back the folding part of the platform.
- ▶ Turn the rotary switch **(27)** upward and hold it in this position until the platform has reached the retraction height.
- ▶ Turn the rotary switch **(30)** upward and hold it in this position until the platform is completely retracted. Observe that the platform can be retracted without obstruction.
- ▶ Turn the rotary switch **(27)** upward and hold it in this position until the platform has reached the vibration safeguard.
- ▶ Close the platform interlock (if present).

## F Operation with One-hand Control easy move®

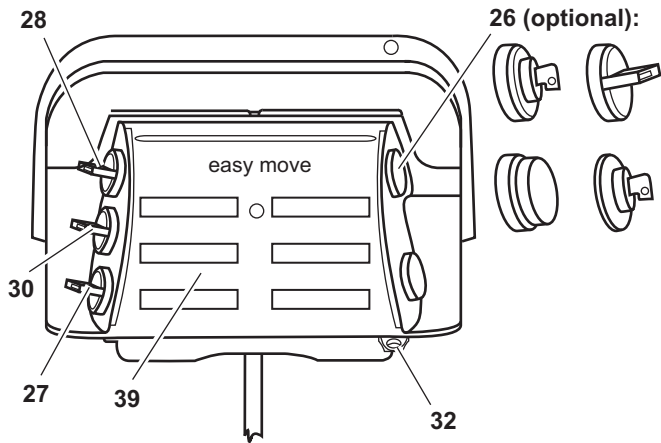

- 26 Optional: key control, rotary switch, emergency-off pushbutton, E30 key
- 27 Rotary switch: lift/lower
- 28 Rotary switch: open/close
- 30 Rotary switch: Retract and extend
- 32 Locking lug
- 39 Operating panel

### DANGER!



#### Risk of accidents and injury!

If the instructions in chapter "General Information" are not observed during operation of the tail lift, personal injuries and material damage can occur.

- ▶ Before operating the tail lift, read chapter "General Operation" from p. 24.

#### Extending and Folding Out the Platform

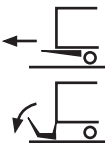

- ▶ Loosen the platform interlock (if present).
- ▶ Turn the rotary switch (30) downward and hold it in this position until the platform is extended.

*The platform is lowered so that it can be extended without obstruction and is extended.*

- ▶ Turn the rotary switch **(27)** downward and hold it in this position until the folded platform has touched the ground.
- ▶ Protect your hands with gloves.
- ▶ Pull the handle with both hands to unfold the folding part of the platform.

### Lowering the Platform



- ▶ Turn the rotary switch **(27)** downward and hold it in this position until the platform has made contact with the ground and is adjusted flush to the ground.

*After the platform has touched the ground it tilts and adjusts to the ground.*

### Lifting the Platform



- ▶ Turn the rotary switch **(27)** upward and hold it in this position until the platform has reached the vehicle loading floor height.

*The platform tilts to the horizontal or preset position before it is lifted into the loading position.*

### Folding In and Retracting the Platform

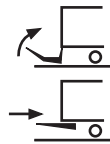

- ▶ Protect your hands with gloves.
- ▶ Pull the handle with both hands to fold back the folding part of the platform.
- ▶ Turn the rotary switch **(30)** upward and hold it in this position until the platform is completely retracted. Observe that the platform can be retracted without obstruction.

*The folded platform lifts or lowers automatically until the optimum retraction position is reached. The platform then retracts until the end position and lifts into the vibration safe-guard.*

- ▶ Close the platform interlock (if present).

## F Operation Using Two-hand Control for MBB R 1500 L FLAT

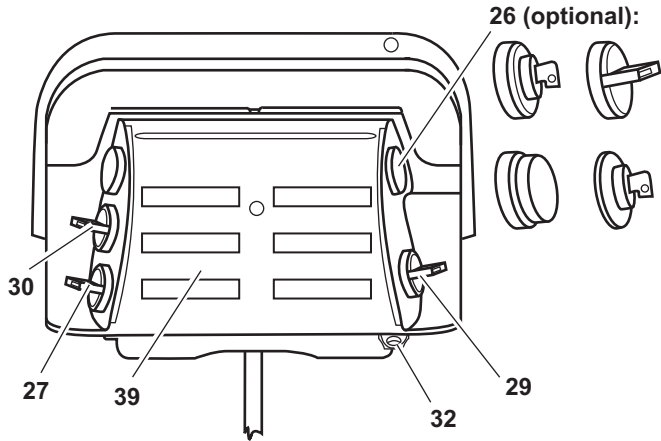

- 26** Optional: Key control, rotary switch, emergency-off pushbutton, E30 key
- 27** Rotary switch: lift/lower
- 29** Rotary switch: additional pushbutton
- 30** Rotary switch: Retract and extend
- 32** Locking lug
- 39** Operating panel

### DANGER!



#### Risk of accidents and injury!

If the instructions in chapter "General Information" are not observed during operation of the tail lift, personal injuries and material damage can occur.

- ▶ Before operating the tail lift, read chapter "General Operation" from p. 24.

#### Extending and Folding Out the Platform

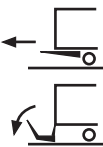

- ▶ Loosen the platform interlock (if present).
- ▶ Turn the rotary switches (**27**) and (**29**) simultaneously downward and hold them in this position until the platform has been lowered.

*The platform is lowered so that it can be extended without obstruction.*

- ▶ Turn the rotary switch **(30)** downward and hold it in this position until the platform is completely extended.
- ▶ Turn the rotary switches **(27)** and **(29)** simultaneously downward and hold them in this position until the folded platform has made contact with the ground.
- ▶ Protect your hands with gloves.
- ▶ Pull the handle with both hands to unfold the folding part of the platform.

### Lowering the Platform



- ▶ Turn the rotary switches **(27)** and **(29)** simultaneously downward and hold them in this position until the platform has made contact with the ground and is adjusted flush to the ground.

### Lifting the Platform



- ▶ Turn the rotary switches **(27)** and **(29)** simultaneously upward and hold them in this position until the platform has reached the vehicle loading floor height.

### Folding In and Retracting the Platform

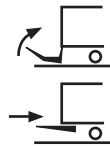

- ▶ Protect your hands with gloves.
- ▶ Pull the handle with both hands to fold back the folding part of the platform.
- ▶ Close the platform interlock (if present).
- ▶ Turn the rotary switches **(27)** and **(29)** simultaneously upward and hold them in this position until the platform has reached the retraction height.
- ▶ Turn the rotary switch **(30)** upward and hold it in this position until the platform is completely retracted. Observe that the platform can be retracted without obstruction.
- ▶ Turn the rotary switches **(27)** and **(29)** simultaneously upward and hold them in this position until the platform has reached the vibration safeguard.

## F Operation Using One-Hand Control for MBB R 1500 L FLAT

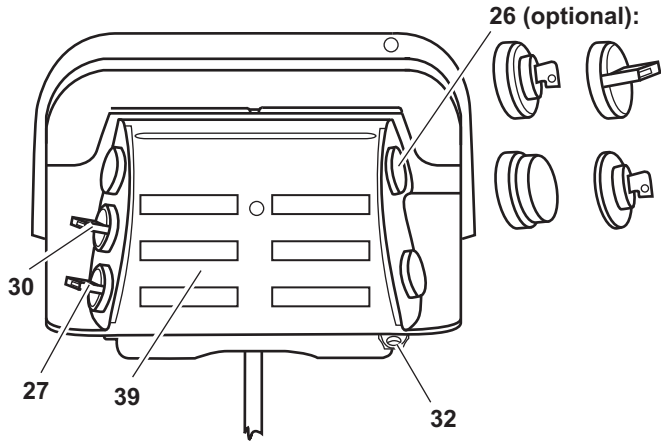

- 26** Optional: key control, rotary switch, emergency-off pushbutton, E30 key
- 27** Rotary switch: lift/lower
- 30** Rotary switch: Retract and extend
- 32** Locking lug
- 39** Operating panel

### DANGER!



#### Risk of accidents and injury!

If the instructions in chapter "General Information" are not observed during operation of the tail lift, personal injuries and material damage can occur.

- ▶ Before operating the tail lift, read chapter "General Operation" from p. 24.

#### Extending and Folding Out the Platform

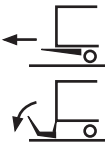

- ▶ Loosen the platform interlock (if present).
- ▶ Turn the rotary switch (**27**) downward and hold it in this position until the platform has been lowered.  
*The platform is lowered so that it can be extended without obstruction.*
- ▶ Turn the rotary switch (**30**) downward and hold it in this position until the platform is completely extended.

- ▶ Turn the rotary switch **(27)** downward and hold it in this position until the folded platform has touched the ground.
- ▶ Protect your hands with gloves.
- ▶ Pull the handle with both hands to unfold the folding part of the platform.

### Lowering the Platform



- ▶ Turn the rotary switch **(27)** downward and hold it in this position until the platform has made contact with the ground and is adjusted flush to the ground.

### Lifting the Platform



- ▶ Turn the rotary switch **(27)** upward and hold it in this position until the platform has reached the vehicle loading floor height.

### Folding In and Retracting the Platform

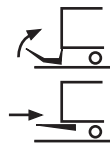

- ▶ Protect your hands with gloves.
- ▶ Pull the handle with both hands to fold back the folding part of the platform.
- ▶ Turn the rotary switch **(27)** upward and hold it in this position until the platform has reached the retraction height.
- ▶ Turn the rotary switch **(30)** upward and hold it in this position until the platform is completely retracted. Observe that the platform can be retracted without obstruction.
- ▶ Turn the rotary switch **(27)** upward and hold it in this position until the platform has reached the vibration safeguard.
- ▶ Close the platform interlock (if present).

## **G** Operation Using Two-hand Control for MBB R 1500 SH - R 2000 LH (Double-folded Platform with Cross Member)

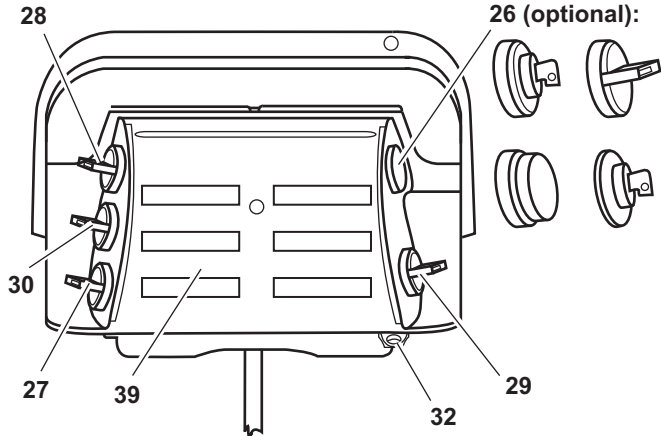

- 26** Optional: key control, rotary switch, emergency-off pushbutton, E30 key
- 27** Rotary switch: lift/lower
- 28** Rotary switch: open/close
- 29** Rotary switch: additional pushbutton
- 30** Rotary switch: retract and extend
- 32** Locking lug
- 39** Operating panel

### **DANGER!**



#### **Risk of accidents and injury!**

If the instructions in chapter “General Operation” are not observed during operation of the tail lift, personal injuries and material damage can occur.

- ▶ Before operating the tail lift, read chapter “General Operation” from p. 24.

### Extending and Folding Out the Platform

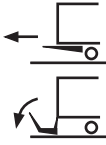

- ▶ Loosen the platform interlock (if present).
- ▶ Turn the rotary switch **(30)** downward and hold it in this position until the platform is folded out once.

*The platform is slightly lowered and then extends. Subsequently it is lowered to the ground and unfolds once.*

- ▶ Protect your hands with gloves.
- ▶ Pull the handle with both hands to unfold the folding part of the platform.

### Lifting the Platform



- ▶ Turn the rotary switches **(27)** and **(29)** simultaneously upward and hold them in this position until the platform has reached the vehicle loading floor height.

*The platform tilts to the horizontal or preset position before it is lifted into the loading position.*

### Lowering the Platform



- ▶ Turn the rotary switches **(27)** and **(29)** simultaneously downward and hold them in this position until the platform has made contact with the ground and is adjusted flush to the ground.

*After the platform has touched the ground it tilts and adjusts to the ground.*

### Setting the BDF Position

- ▶ Turn the rotary switches **(27)** and **(29)** simultaneously upward and hold them in this position until the platform has reached the vehicle loading floor height.
- ▶ Turn the rotary switch **(30)** upward and hold it in this position until the platform has reached the loading position.
- ▶ Shift the movable stop on the guide rail until the outer initiator is dampened.

### Moving to the BDF Position

- ▶ Turn the rotary switches **(27)** and **(29)** simultaneously upward and hold them in this position until the torsion frame is located above its horizontal position.
- ▶ Turn the rotary switch **(30)** upwards.  
*The platform moves to the preset BDF position.*
- ▶ Turn the rotary switches **(27)** and **(29)** simultaneously upward and hold them in this position until the platform has reached the loading position.

### Folding In and Retracting the Platform

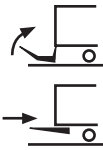

- ▶ Turn the rotary switches **(27)** and **(29)** simultaneously downward and hold them in this position until the platform has reached the ground.
- ▶ Protect your hands with gloves.
- ▶ Pull the handle with both hands to fold back the folding part of the platform.
- ▶ Close the platform interlock (if present).
- ▶ Turn the rotary switch **(30)** upward and hold it in this position until the platform has reached the vibration safeguard.  
*The platform automatically folds over and then lifts into the retraction position. Subsequently it retracts completely and lifts into the vibration safeguard.*



## **G** Operation Using Two-hand Control for MBB R 750 SM - R 2000 LM (Double-folded Platform without Cross Member)

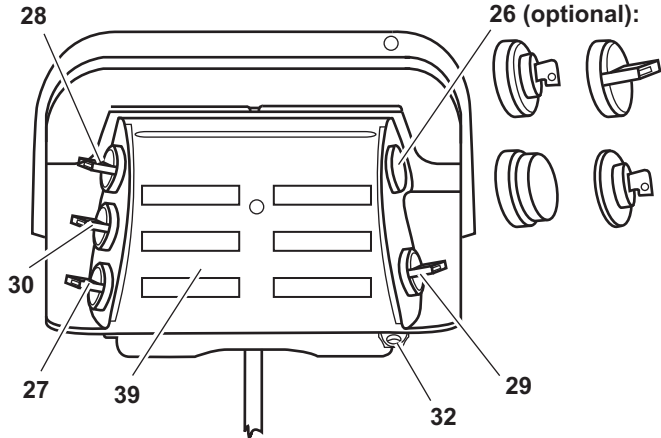

- 26** Optional: key control, rotary switch, emergency-off pushbutton, E30 key
- 27** Rotary switch: lift/lower
- 28** Rotary switch: open/close
- 29** Rotary switch: additional pushbutton
- 30** Rotary switch: retract and extend
- 32** Locking lug
- 39** Operating panel

### **DANGER!**



#### **Risk of accidents and injury!**

If the instructions in chapter “General Operation” are not observed during operation of the tail lift, personal injuries and material damage can occur.

- ▶ Before operating the tail lift, read chapter “General Operation” from p. 24.

### Extending and Folding Out the Platform

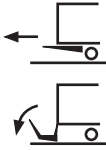

- ▶ Loosen the platform interlock (if present).
- ▶ Turn the rotary switch **(30)** downward and hold it in this position until the platform has reached the vertical position.  
*The platform is slightly lowered and then extends. Subsequently it lowers to the ground and tilts into an approximate vertical position.*
- ▶ Protect your hands with gloves.
- ▶ Swivel the platform with both hands forward by approximately 20°.
- ▶ Turn the rotary switch **(30)** downward and hold it in this position until the platform touches the ground.  
*The platform lowers to the ground and then unfolds once.*
- ▶ Protect your hands with gloves.
- ▶ Pull the handle with both hands to unfold the second folding part of the platform.

### Lifting the Platform



- ▶ Turn the rotary switches **(27)** and **(29)** simultaneously upward and hold them in this position until the platform has reached the vehicle loading floor height.  
*The platform tilts to the horizontal or preset position before it is lifted into the loading position.*

### Lowering the Platform



- ▶ Turn the rotary switches **(27)** and **(29)** simultaneously downward and hold them in this position until the platform has made contact with the ground and is adjusted flush to the ground.  
*After the platform has touched the ground it tilts and adjusts to the ground.*

### Setting the BDF Position

- ▶ Turn the rotary switches **(27)** and **(29)** simultaneously upward and hold them in this position until the platform has reached the vehicle loading floor height.
- ▶ Turn the rotary switch **(30)** upward and hold it in this position until the platform has reached the loading position.
- ▶ Shift the movable stop on the guide rail until the outer initiator is dampened.

### Moving to the BDF Position

- ▶ Turn the rotary switches **(27)** and **(29)** simultaneously upward and hold them in this position until the torsion frame is located above its horizontal position.
- ▶ Turn the rotary switch **(30)** upwards.  
*The platform moves to the preset BDF position.*
- ▶ Turn the rotary switches **(27)** and **(29)** simultaneously upward and hold them in this position until the platform has reached the loading position.

### Folding In and Retracting the Platform

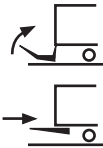

- ▶ Turn the rotary switches **(27)** and **(29)** simultaneously downward and hold them in this position until the platform has reached the ground.
- ▶ Protect your hands with gloves.
- ▶ Fold in the link bridge (if present).
- ▶ Pull the handle with both hands to fold back the folding part of the platform.
- ▶ Turn the rotary switch **(30)** upward and hold it in this position until the platform has reached the vertical position.
- ▶ Tilt the platform with both hands forward by approximately 20°.
- ▶ Turn the rotary switch **(30)** upward and hold it in this position until the platform has reached the vibration safeguard.  
*After the platform folded over automatically, it lifts itself into the vibration safeguard.*
- ▶ Close the platform interlock (if present).



## **G** Operation Using Two-hand Control for MBB R 750 SM - R 2000 LM (Double-folded Platform with Cross Member)

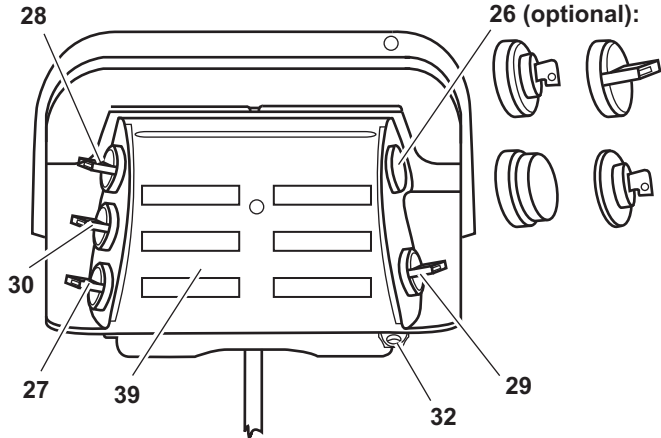

- 26** Optional: key control, rotary switch, emergency-off pushbutton, E30 key
- 27** Rotary switch: lift/lower
- 28** Rotary switch: open/close
- 29** Rotary switch: additional pushbutton
- 30** Rotary switch: retract and extend
- 32** Locking lug
- 39** Operating panel

### **DANGER!**



#### **Risk of accidents and injury!**

If the instructions in chapter “General Operation” are not observed during operation of the tail lift, personal injuries and material damage can occur.

- Before operating the tail lift, read chapter “General Operation” from p. 24.

### Extending and Folding Out the Platform

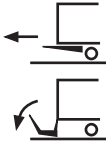

- ▶ Loosen the platform interlock (if present).
- ▶ Turn the rotary switches **(27)** and **(29)** simultaneously downward and hold them in this position until the platform has been lowered.
 

*The platform is lowered so that it can be extended without obstruction.*
- ▶ Turn the rotary switch **(30)** downward and hold it in this position until the platform is completely extended.
- ▶ Turn the rotary switches **(27)** and **(29)** simultaneously downward and hold them in this position until the folded platform has made contact with the ground.
- ▶ Protect your hands with gloves.
- ▶ Pull the platform edge with both hands to unfold the platform to the rear.
- ▶ Pull the folding part of the platform with both hands to unfold it to the rear.

### Lowering the Platform



- ▶ Turn the rotary switches **(27)** and **(29)** simultaneously downward and hold them in this position until the platform has made contact with the ground and is adjusted flush to the ground.
 

*After the platform has touched the ground it tilts and adjusts to the ground.*

### Lifting the Platform



- ▶ Turn the rotary switches **(27)** and **(29)** simultaneously upward and hold them in this position until the platform has reached the vehicle loading floor height.
 

*The platform tilts to the horizontal or preset position before it is lifted into the loading position.*

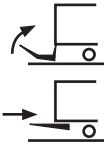

### Folding In and Retracting the Platform

- ▶ Protect your hands with gloves.
- ▶ Grasp the platform edge with both hands to fold back the platform.
- ▶ Pull the folding part of the platform with both hands to fold it back.
- ▶ Close the platform interlock (if present).
- ▶ Swivel the platform up to the roller at the support tube.
- ▶ Turn the rotary switches **(27)** and **(29)** simultaneously upward and hold them in this position until the platform has reached the retraction height.
- ▶ Turn the rotary switch **(30)** upward and hold it in this position until the platform is completely retracted. Observe that the platform can be retracted without obstruction.

Turn the rotary switches **(27)** and **(29)** simultaneously upward and hold them in this position until the platform has reached the vibration safeguard.



## K Operation Using Two-hand Control

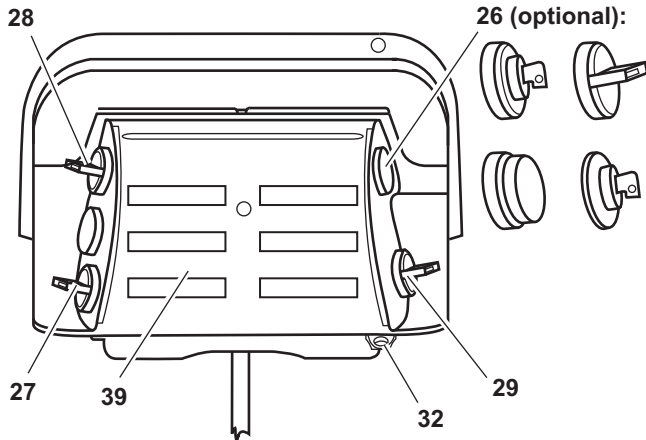

- 26 Optional: key control, rotary switch, emergency-off pushbutton, E30 key
- 27 Rotary switch: lift/lower
- 28 Rotary switch: open/close
- 29 Rotary switch: additional pushbutton
- 32 Locking lug
- 39 Operating panel

### DANGER!



#### Risk of accidents and injury!

If the instructions in chapter “General Operation” are not observed during operation of the tail lift, personal injuries and material damage can occur.

- ▶ Before operating the tail lift, read chapter “General Operation” from p. 24.

#### Folding Out the Platform



- ▶ Loosen the platform interlock (if present).
- ▶ Turn the rotary switches (27) and (29) simultaneously downward and hold them in this position until the platform has almost reached the vertical position.  
*The platform is lowered slightly and then tilts via the guide pulley almost to the vertical position.*
- ▶ Protect your hands with gloves.

- ▶ Pull the handle with both hands to fold out the platform to the rear.
- ▶ Turn the rotary switches **(28)** and **(29)** simultaneously downward and hold them in this position until the platform has reached the horizontal position.
- ▶ Fold the folding part of the platform with both hands to the operating position.

### Lowering the Platform



- ▶ Turn the rotary switches **(27)** and **(29)** simultaneously downward and hold them in this position until the platform has made contact with the ground.

*After the platform has touched the ground it tilts and adjusts to the ground.*

### Lifting the Platform



- ▶ Turn the rotary switches **(27)** and **(29)** simultaneously upward and hold them in this position until the platform has reached the loading position.

### Folding In the Platform



- ▶ Make sure that the platform is in horizontal position touching the ground.
- ▶ Protect your hands with gloves.
- ▶ Unfold the folding part of the platform with both hands from the operating position onto the stationary part of the platform.
- ▶ Turn the rotary switches **(28)** and **(29)** simultaneously upward and hold them in this position until the platform has reached the vertical position.
- ▶ Protect your hands with gloves.
- ▶ Use both hands to push the platform against the guide pulley.
- ▶ Turn the rotary switches **(27)** and **(29)** simultaneously upward and hold them in this position until the platform has reached the transport position.
- ▶ Close the platform interlock (if present).

## K Operation Using One-hand Control

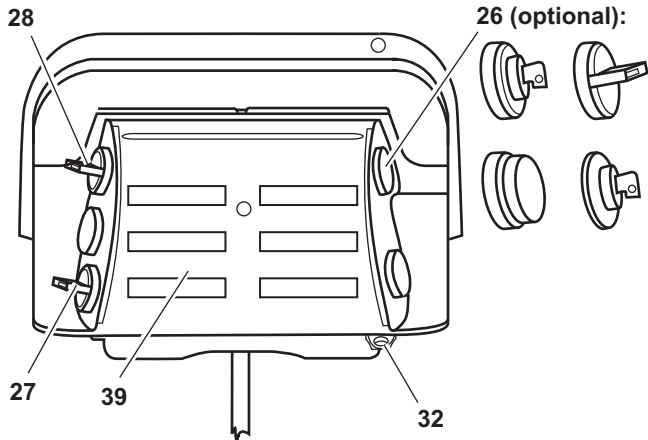

- 26** Optional: key control, rotary switch, emergency-off pushbutton, E30 key
- 27** Rotary switch: lift/lower
- 28** Rotary switch: open/close
- 32** Locking lug
- 39** Operating panel

### DANGER!



#### Risk of accidents and injury!

If the instructions in chapter “General Operation” are not observed during operation of the tail lift, personal injuries and material damage can occur.

- ▶ Before operating the tail lift, read chapter “General Operation” from p. 24.

#### Folding Out the Platform



- ▶ Loosen the platform interlock (if present).
- ▶ Turn the rotary switch (**27**) downward and hold it in this position until the platform has reached the vertical position.  
*The platform is lowered slightly and then tilts via the guide pulley almost to the vertical position.*
- ▶ Protect your hands with gloves.
- ▶ Pull the handle with both hands to fold out the platform to the rear.

- ▶ Turn the rotary switch **(28)** downward and hold it in this position until the platform has reached the horizontal position.
- ▶ Fold the folding part of the platform with both hands to the operating position.

### Lifting the Platform



- ▶ Turn the rotary switch **(27)** upward and hold it in this position until the platform has reached the loading position.

### Lowering the Platform



- ▶ Turn the rotary switch **(27)** upward and hold it in this position until the platform is adjusted flush to the ground.  
*After the platform has touched the ground it tilts and adjusts to the ground.*

### Folding In the Platform

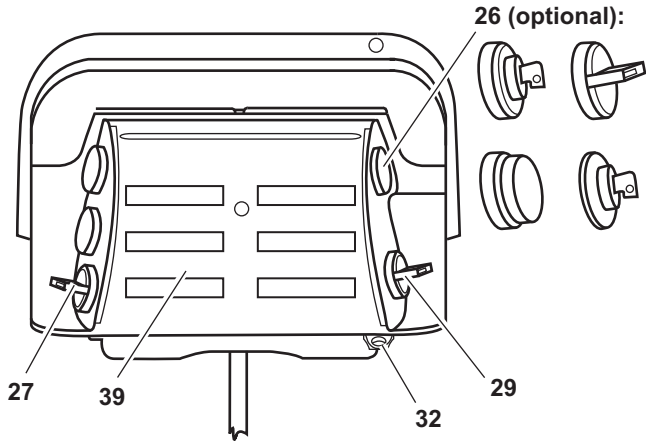

- ▶ Make sure that the platform is in horizontal position touching the ground.
- ▶ Protect your hands with gloves.
- ▶ Unfold the folding part of the platform with both hands from the operating position onto the stationary part of the platform.
- ▶ Turn the rotary switch **(28)** upward and hold it in this position until the platform has reached the vertical position.  
*The platform tilts from the horizontal to the vertical position.*
- ▶ Protect your hands with gloves.
- ▶ Use both hands to push the platform against the guide pulley.
- ▶ Turn the rotary switch **(27)** upward and hold it in this position until the platform has reached the transport position.
- ▶ Close the platform interlock (if present).

**B L M** Operation Using Two-hand Control

- 26** Optional: key control, rotary switch, emergency-off pushbutton, E30 key
- 27** Rotary switch: lift/lower
- 29** Rotary switch: additional pushbutton
- 32** Locking lug
- 39** Operating panel

**DANGER!****Risk of accidents and injury!**

If the instructions in chapter “General Operation” are not observed during operation of the tail lift, personal injuries and material damage can occur.

- ▶ Before operating the tail lift, read chapter “General Operation” from p. 24.

### Folding Out the Platform



- ▶ Loosen the platform interlock (if present).
- ▶ Turn the rotary switches **(27)** and **(29)** simultaneously downward and hold them in this position until the platform has made contact with the ground.
- ▶ Protect your hands with gloves.
- ▶ Pull the handle with both hands to unfold the folding part of the platform.

### Lifting the Platform



- ▶ Turn the rotary switches **(27)** and **(29)** simultaneously upward and hold them in this position until the platform has reached the loading position.

*The platform tilts to the horizontal or preset position and is then lifted.*

### Lowering the Platform



- ▶ Turn the rotary switches **(27)** and **(29)** simultaneously downward and hold them in this position until the platform has made contact with the ground.

*After the platform has touched the ground it tilts and adjusts to the ground.*

### Folding In the Platform



- ▶ Make sure that the platform is in horizontal position touching the ground.
- ▶ Protect your hands with gloves.
- ▶ Unfold the folding part of the platform with both hands from the operating position onto the stationary part of the platform.
- ▶ Close the platform interlock (if present).
- ▶ Swivel the platform up to the roller at the support tube.
- ▶ Turn the rotary switches **(27)** and **(29)** simultaneously upward and hold them in this position until the platform is folded away under the vehicle.

*The platform lifts and is moved under the vehicle.*

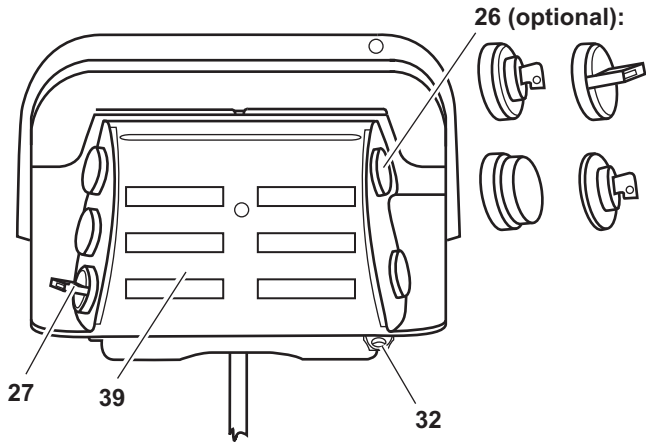
**B L M** Operation Using One-hand Control

- 26** Optional: key control, rotary switch, emergency-off pushbutton, E30 key
- 27** Rotary switch: lift/lower
- 32** Locking lug
- 39** Operating panel

**DANGER!****Risk of accidents and injury!**

If the instructions in chapter “General Operation” are not observed during operation of the tail lift, personal injuries and material damage can occur.

- ▶ Before operating the tail lift, read chapter “General Operation” from p. 24.

### Folding Out the Platform



- ▶ Loosen the platform interlock (if present).
- ▶ Turn the rotary switch (27) upward and hold it in this position until the platform is adjusted flush to the ground.
- ▶ Protect your hands with gloves.
- ▶ Pull the handle with both hands to unfold the folding part of the platform.

### Lifting the Platform



- ▶ Turn the rotary switch (27) upward and hold it in this position until the platform has reached the loading position.  
*The platform tilts to the horizontal or preset position and is then lifted.*

### Lowering the Platform



- ▶ Turn the rotary switch (27) upward and hold it in this position until the platform is adjusted flush to the ground.  
*After the platform has touched the ground it tilts and adjusts to the ground.*

### Folding In the Platform

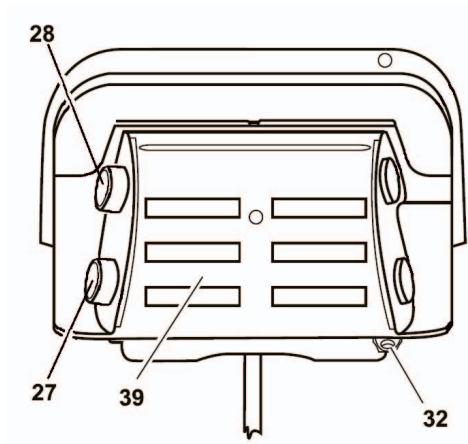

- ▶ Make sure that the platform is in horizontal position touching the ground.
- ▶ Protect your hands with gloves.
- ▶ Unfold the folding part of the platform with both hands from the operating position onto the stationary part of the platform.
- ▶ Close the platform interlock (if present).
- ▶ Swivel the platform up to the roller at the support tube.
- ▶ Turn the rotary switch (27) upward and hold it in this position until the platform is folded away under the vehicle.  
*The platform lifts and is moved under the vehicle.*

**M** Operation F 600 L

- 27 Pushbutton: lower
- 28 Pushbutton: lift
- 32 Locking lug
- 39 Operating panel

**DANGER!****Risk of accidents and injury!**

If the instructions in chapter “General Operation” are not observed during operation of the tail lift, personal injuries and material damage can occur.

- ▶ Before operating the tail lift, read chapter “General Operation” from p. 24.

### Folding Out the Platform



- ▶ Loosen the platform interlock (if present).
- ▶ Press the pushbutton **(27)** and hold.
- ▶ Protect your hands with gloves.
- ▶ Pull the handle with both hands to unfold the folding part of the platform.

### Lifting the Platform



- ▶ Press the pushbutton **(28)** and hold it in this position until the platform has reached the loading position.  
*The platform tilts to the horizontal or preset position and is then lifted.*

### Lowering the Platform



- ▶ Press the pushbutton **(27)** and hold it in this position until the platform is adjusted flush to the ground.  
*After the platform has touched the ground it tilts and adjusts to the ground.*

### Folding In the Platform

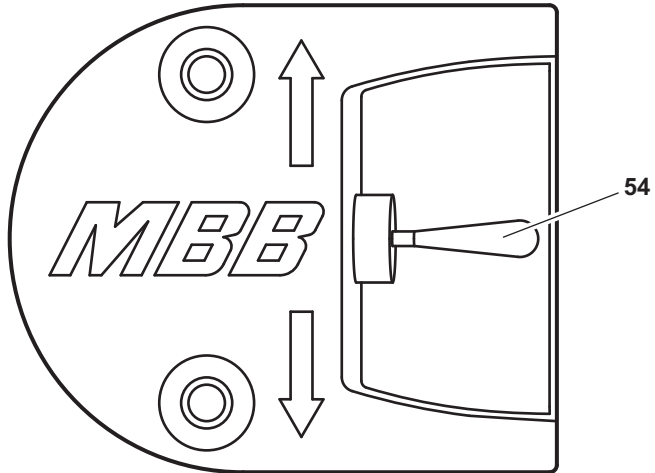

- ▶ Make sure that the platform is in horizontal position touching the ground.
- ▶ Protect your hands with gloves.
- ▶ Unfold the folding part of the platform with both hands from the operating position onto the stationary part of the platform.
- ▶ Close the platform interlock (if present).
- ▶ Swivel the platform up to the roller at the support tube.
- ▶ Press the pushbutton **(28)** and hold it in this position until the platform is folded away under the vehicle.  
*The platform lifts and is moved under the vehicle.*

**B M<sup>h</sup>** Operation Using One-hand Control**54** Toggle switch**DANGER!****Risk of accidents and injury!**

If the instructions in chapter “General Operation” are not observed during operation of the tail lift, personal injuries and material damage can occur.

- ▶ Before operating the tail lift, read chapter “General Operation” from p. 24.

### Folding Out the Platform



- ▶ Loosen the platform interlock (if present).
- ▶ Press the toggle switch **(54)** downward and hold it in this position until the torsion frame touches the ground.
- ▶ Protect your hands with gloves.
- ▶ Pull the handle with both hands to swivel the platform to the horizontal position.
- ▶ Pull the handle with both hands to unfold the folding part of the platform.

### Lowering the Platform



- ▶ Press the toggle switch **(54)** downward and hold it in this position until the platform reaches the ground tilt while lowering.

### Lifting the Platform



- ▶ Press the toggle switch **(54)** upward and hold it in this position until the platform reaches the loading position while lifting.

### Folding In the Platform



- ▶ Make sure that the platform is in horizontal position touching the ground.
- ▶ Protect your hands with gloves.
- ▶ Fold the platform tip onto the platform.
- ▶ Close the platform interlock (if present).
- ▶ Swivel the platform up to the roller at the support tube.

## V Operation Using two Hand Cable Controls with three Pushbuttons, each

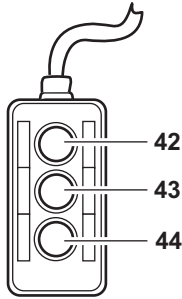

### Hand Cable Control 1

- 42 Pushbutton: lift platform
- 43+42 Pushbutton: close platform
- 44 Pushbutton: lower platform
- 43+44 Pushbutton: open platform

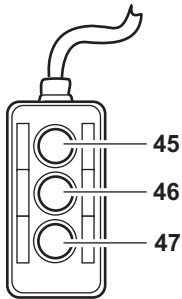

### Hand Cable Control 2

- 45 Pushbutton: lift platform
- 46+45 Pushbutton: fold in link bridge
- 47 Pushbutton: lower platform
- 46+47 Pushbutton: fold out link bridge

## DANGER!



### Risk of accidents and injury!

If the instructions in chapter "General Operation" are not observed during operation of the column lift, personal injuries and material damage can occur.

- ▶ Before operating the column lift, read chapter "General Operation" from p. 24.

**DANGER!****Crushing hazard due to wrong operator position!**

If the operator does not stand in the correct position when moving the platform via the hand cable control, personal injury and material damage may occur.

- ▶ Make sure to stand in the correct position (see the picture below) when operating the platform with the hand cable control. Do not stand in another position.
- ▶ When operating the platform with the hand cable control while standing inside the vehicle, always keep a minimum distance of 250 mm from the sill.
- ▶ Do not stand in the area near the platform edge where you risk to crush your feet when the platform approaches the vehicle sill.
- ▶ Exclusively stand in the platform area marked with the foot symbols in the illustration when moving the platform.
- ▶ When standing on the ground for operating the platform, keep a minimum distance of 1 m from all platform rims.
- ▶ Make sure that you can see the entire working area and that no other person stays on or near the platform.

**Operator positions  
for hand cable  
control**

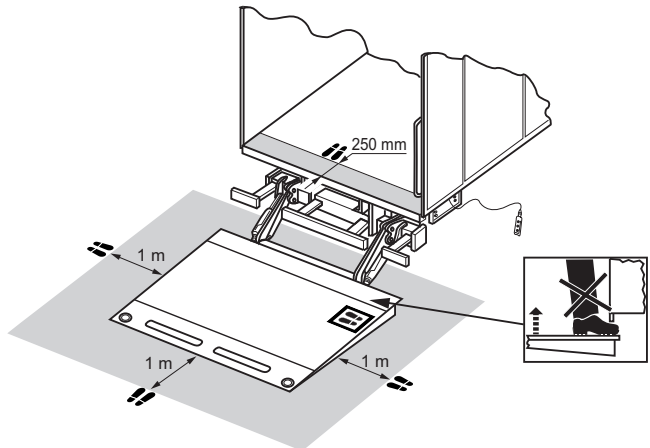

**DANGER!****Risk of accidents and injury!**

Failure to observe the instructions below when operating the column lift may result in persons or objects falling off the platform, causing serious injuries or damage to property.

- ▶ Prior to lifting or lowering the platform always set upright the two safety railings.
- ▶ When loading rolling containers without brakes always set the link bridge upright to use it as a roll stop.
- ▶ Use the roll stop towards the vehicle rear side to prevent containers of this type from rolling off the platform and into the vehicle in an uncontrollable manner.
- ▶ When loading the platform, leave enough free space for the operator (minimum 50 x 60 cm).
- ▶ When operating the column lift from a position on the platform, exclusively use the hand cable control 2. As this hand cable control only allows you to "lift" and "lower" the platform or to "fold in" and "fold out" the link bridge, it is not possible to accidentally "open" or "close" the platform and, thus, tilt it.

**CAUTION!****Risk of injuries or damage to the vehicle!**

An insufficient load carrying capacity of the ground may result in damage to the vehicle or load.

- ▶ Make sure that the ground can carry the weight of both the vehicle tail and the load.
- ▶ When working with a loading ramp, make sure that the link bridge has sufficient contact with the ramp.

### Opening the Platform



- ▶ Press the pushbutton **(43)** on the hand cable control 1 and hold it in this position. Briefly after this press and hold the pushbutton **(44)** on the same hand cable control. Hold both pushbuttons in this position until the platform is horizontal.

#### Note:

When loading the platform, you can simply compensate for any height differences by using the “open” or “close” functions.

### Setting the Safety Railing Upright



- ▶ Grasp one of the safety railings lying on the platform and swivel it up.
- ▶ Secure the safety railing in its upright position. For this purpose, engage the lug of the fastener to the hook.
- ▶ Repeat these steps for the other safety railing.

### Lifting the Platform



- ▶ If required, open the top flap. This is necessary if you want to use the upper vehicle deck.
- ▶ Press either the pushbutton **(42)** on hand cable control 1 or the pushbutton **(45)** on hand cable control 2 and hold it in this position until the platform has reached the required height.

### Lowering the Platform



- ▶ Press either the pushbutton **(44)** on hand cable control 1 or the pushbutton **(47)** on hand cable control 2 and hold it in this position until the platform has reached the required height.

### Folding Out the Link Bridge



- ▶ Press the pushbutton **(46)** on the hand cable control 2 and hold it in this position. Briefly after this press and hold the pushbutton **(47)** on the same hand cable control. Hold both pushbuttons in this position until the link bridge has reached the required position.

### Folding In the Link Bridge



- ▶ Press the pushbutton **(46)** on the hand cable control 2 and hold it in this position. Briefly after this press and hold the pushbutton **(45)** on the same hand cable control. Hold both pushbuttons in this position until the link bridge has reached the required position.

### Putting Down the Safety Railings



- ▶ Open the fastener of the first safety railing and swivel down the railing until it lies on the platform.
- ▶ Repeat this procedure for the second safety railing.

### Closing the Platform



- ▶ Press the pushbutton **(43)** on the hand cable control 1 and hold it in this position. Briefly after this press and hold the pushbutton **(42)** on the same hand cable control. Hold both pushbuttons in this position until the platform is completely closed.



## A B C E F G K L M

**Optional Operating Method: Foot Control**

Platform with 2 foot controls  
(standard control)

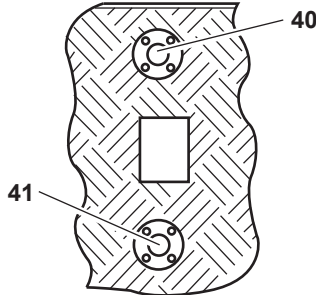

- 40** Foot control  
(at platform rim)
- 41** Foot control

Platform with 3 foot controls  
(control unit with basic board)

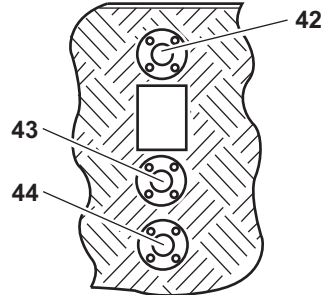

- 42** Additional foot control  
(at platform rim)
- 43** Foot control: lift
- 44** Foot control: lower

**DANGER!****Risk of accidents and injury!**

If the instructions in chapter “General Operation” not observed during operation of the tail lift, personal injuries and material damage can occur.

- ▶ Before operating the tail lift, read chapter “General Operation” from p. 24.

**Lowering the Platform****Platform with 2 Foot Controls**

- ▶ Step on the foot control (**40**) and keep it in this position.
- ▶ After one second at the earliest and three seconds at the latest, step on the foot control (**41**) and keep it in this position.

*The platform is lowered and automatically adjusts to the ground.*

- Note:** If both foot controls are not actuated within three seconds, the foot controls are disabled for a short time. Wait a few seconds before you repeat the procedure.



### Platform with 3 Foot Controls

- ▶ Step on the foot control **(44)** and on the additional foot control **(42)**.

*The platform is lowered and automatically adjusts to the ground.*

### Lifting the Platform

#### Platform with 2 Foot Controls



- ▶ Step on the foot control **(41)** and keep it in this position.
- ▶ After one second at the earliest and three seconds at the latest, step on the foot control **(40)** and keep it in this position.

*Before the platform is lifted it tilts to the horizontal position.*

#### Note:

If both foot controls are not actuated within three seconds, the foot controls are disabled for a short time. Wait a few seconds before you repeat the procedure.

#### Platform with 3 Foot Controls



- ▶ Step on the foot control **(43)** and on the additional foot control **(42)**.

*Before the platform is lifted it tilts to the horizontal position.*

A B C E F G K L M

## Optional Operating Method: Hand Cable Control with two Pushbuttons

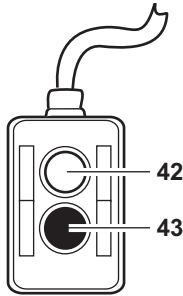

42 Pushbutton: lift

43 Pushbutton: lower

### DANGER!



#### Risk of accidents and injury!

If the instructions in chapter "General Information" are not observed during operation of the tail lift, personal injuries and material damage can occur.

- ▶ Before operating the tail lift, read chapter "General Operation" from p. 24.

**DANGER!****Crushing hazard due to wrong operator position!**

If the operator does not stand in the correct position when moving the platform via the hand cable control, personal injury and material damage may occur .

- ▶ Make sure to stand in the correct position (see the picture below) when operating the platform with the hand cable control. Do not stand in another position.
- ▶ When operating the platform with the hand cable control while standing inside the vehicle, always keep a minimum distance of 250 mm from the sill.
- ▶ Do not stand in the squeezing area where the platform approaches the vehicle body.
- ▶ Exclusively stand in the platform area marked with the foot symbols in the illustration when moving the platform.
- ▶ When standing on the ground for operating the platform, keep a minimum distance of 1 m from all platform rims.
- ▶ Make sure that you can see the entire working area and that no other person stays on or near the platform.

**Operator positions  
for hand cable  
control**

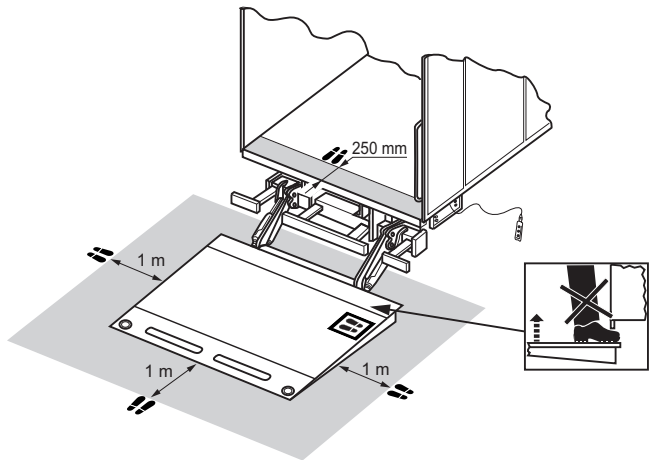

### Lowering the Platform



- ▶ Press the pushbutton **(43)** and keep it pressed until the platform is adjusted flush to the ground.

*After the platform has touched the ground it tilts and adjusts to the ground.*

### Lifting the Platform



- ▶ Press the pushbutton **(42)** and keep it pressed until the platform has reached the loading position.

*Before the platform is lifted it tilts to the horizontal position.*

## A C E F G K L M

### Optional Operating Method: Hand Cable Control with three Pushbuttons

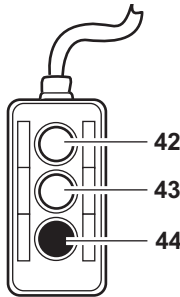

- 42** Pushbutton: lift
- 43** Pushbutton: tilt
- 44** Pushbutton: lower

## DANGER!



### Risk of accidents and injury!

If the instructions in chapter "General Information" are not observed during operation of the tail lift, personal injuries and material damage can occur.

- ▶ Before operating the tail lift, read chapter "General Operation" from p. 24.

**DANGER!****Crushing hazard due to wrong operator position!**

If the operator does not stand in the correct position when moving the platform via the hand cable control, personal injury and material damage may occur .

- ▶ Make sure to stand in the correct position (see the picture below) when operating the platform with the hand cable control. Do not stand in another position.
- ▶ When operating the platform with the hand cable control while standing inside the vehicle, always keep a minimum distance of 250 mm from the sill.
- ▶ Do not stand in the squeezing area where the platform approaches the vehicle body.
- ▶ Exclusively stand in the platform area marked with the foot symbols in the illustration when moving the platform.
- ▶ When standing on the ground for operating the platform, keep a minimum distance of 1 m from all platform rims.
- ▶ Make sure that you can see the entire working area and that no other person stays on or near the platform.

**Operator positions  
for hand cable  
control**

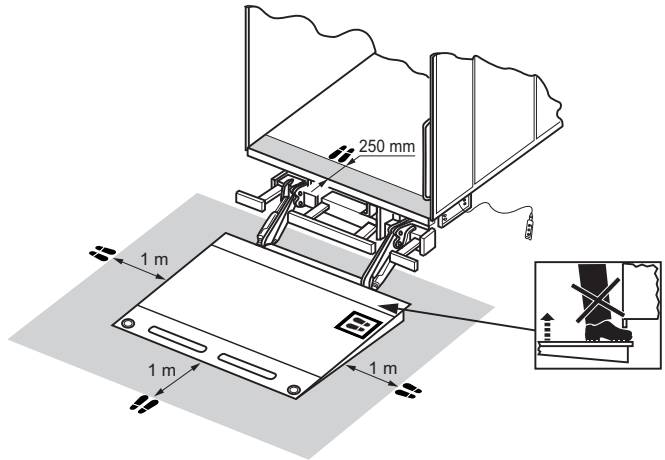

### Lowering the Platform



- ▶ Press the pushbutton **(44)** and keep it pressed until the platform is adjusted flush to the ground.

*After the platform has touched the ground it tilts and adjusts to the ground.*

### Lifting the Platform



- ▶ Press the pushbutton **(42)** and keep it pressed until the platform has reached the loading position.

*Before the platform is lifted it tilts to the horizontal position.*

### Setting the Platform to its Horizontal Position

- ▶ To adjust a steeper tilt of the platform, press both pushbuttons **(42)** and **(43)** simultaneously.
- ▶ To adjust a flatter tilt or to adjust the platform flush to the ground, press both pushbuttons **(43)** and **(44)** simultaneously.

## A Optional Operating Method: Hand Cable Control with four Pushbuttons for MBB C 750 SX

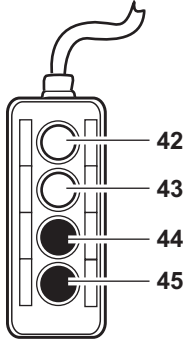

- 42 Pushbutton: lift
- 43 Pushbutton: lower
- 44 Pushbutton: Lift scissors
- 45 Pushbutton: Lower scissors

### DANGER!



#### Risk of accidents and injury!

If the instructions in chapter "General Information" are not observed during operation of the tail lift, personal injuries and material damage can occur.

- ▶ Before operating the tail lift, read chapter "General Operation" from p. 24.

**DANGER!****Crushing hazard due to wrong operator position!**

If the operator does not stand in the correct position when moving the platform via the hand cable control, personal injury and material damage may occur .

- ▶ Make sure to stand in the correct position (see the picture below) when operating the platform with the hand cable control. Do not stand in another position.
- ▶ When operating the platform with the hand cable control while standing inside the vehicle, always keep a minimum distance of 250 mm from the sill.
- ▶ Do not stand in the squeezing area where the platform approaches the vehicle body.
- ▶ Exclusively stand in the platform area marked with the foot symbols in the illustration when moving the platform.
- ▶ When standing on the ground for operating the platform, keep a minimum distance of 1 m from all platform rims.
- ▶ Make sure that you can see the entire working area and that no other person stays on or near the platform.

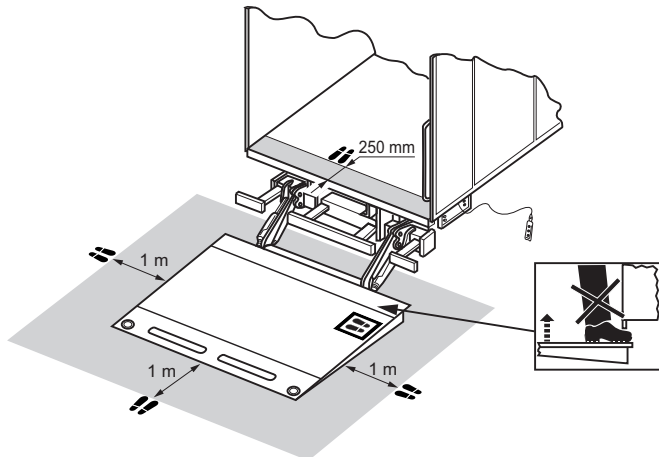
**Operator positions  
for hand cable  
control**

### Lowering the Platform



- ▶ Press the pushbutton **(43)** and keep it pressed until the platform is adjusted flush to the ground.

*After the platform has touched the ground it tilts and adjusts to the ground.*

### Lifting the Platform



- ▶ Press the pushbutton **(42)** and keep it pressed until the platform has reached the loading position.

*Before the platform is lifted it tilts to the horizontal position.*

### Lifting the scissors



- ▶ Press the pushbutton **(44)** and keep it pressed until the platform has reached the loading position.

### Lowering the scissors



- ▶ Press the pushbutton **(45)** and keep it pressed until the platform has reached the loading position.

A C F G K L

## Optional Operating Method: Wireless Remote Control Unit (Standard)

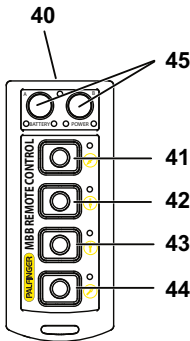

- 40 Slide switch: On/Off
- 41 Pushbutton: open
- 42 Pushbutton: lower
- 43 Pushbutton: lift
- 44 Pushbutton: close
- 45 Pushbutton: special function

### DANGER!



#### Risk of accidents and injury!

If the instructions in chapter "General Information" are not observed during operation of the tail lift, personal injuries and material damage can occur.

- ▶ Before operating the tail lift, read chapter "General Operation" from p. 24.

**Note:** A detailed description to the wireless remote control unit is part of the manual which is in the package of the wireless remote control unit.

#### Switching the Wireless Remote Control Unit On/Off

- ▶ In order to connect, slide the switch (40) upwards. The transmitter remains connected, until the switch (40) will have been slid downwards.

#### Lowering the Platform



- ▶ Press the pushbutton (42) and keep it pressed until the platform is adjusted flush to the ground.

*After the platform has touched the ground it tilts and adjusts to the ground.*

### Lifting the Platform



- ▶ Press the pushbutton **(43)** and keep it pressed until the platform has reached the loading position.

*Before the platform is lifted it tilts to the horizontal position.*

### Opening the Platform



- ▶ Loosen the platform interlock (if present).
- ▶ Press the pushbutton **(41)** and keep it pressed until the platform is completely open.

*If an optional load safety device is present, the platform is lowered a small amount and then unfolds to the horizontal operating position.*

### Closing the Platform



- ▶ Press the pushbutton **(44)** and keep it pressed until the platform is completely closed.

*If an optional load safety device is present, the platform closes approximately to 80° and is lowered a small amount. Subsequently it moves to the vertical transport position and is lifted into the load safety device.*

- ▶ Close the platform interlock (if present).

### Setting the Platform to its Horizontal Position

- ▶ In order to obtain a steeper platform tilt angle, press the pushbutton **(44)**.
- ▶ In order to obtain a flatter platform tilt angle or let the platform make contact with the ground, press the pushbutton **(41)**.

## A C E K L Special Operating Elements

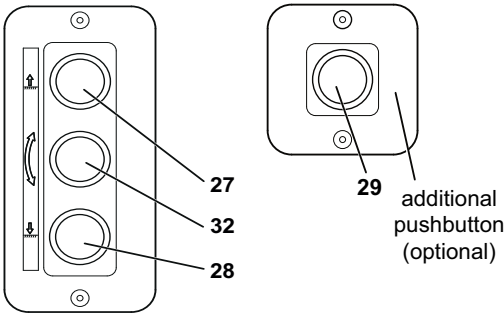

- 27 Pushbutton: lift/close
- 28 Pushbutton: lower/open
- 29 Pushbutton: additional pushbutton
- 32 Pushbutton: close/open

### DANGER!



#### Risk of accidents and injury!

If the instructions in chapter “General Operation” are not observed during operation of the tail lift, personal injuries and material damage can occur.

- ▶ Before operating the tail lift, read chapter “General Operation” from p. 24.

#### Opening the Platform



- ▶ Loosen the platform interlock (if present).
- ▶ Press the pushbuttons **(28)**, **(32)** and optionally **(29)** simultaneously and hold them in this position until the platform has reached the horizontal operating position.

#### Lowering the Platform



- ▶ Press the pushbuttons **(28)** and optionally **(29)** simultaneously and hold them in this position until the platform has made contact with the ground.

*After the platform has touched the ground it tilts and adjusts to the ground.*

### Lifting the Platform



- ▶ Press the pushbuttons **(27)** and optionally **(29)** simultaneously and hold them in this position until the platform has reached the vehicle loading floor height.

*The platform tilts to the horizontal or preset position before it is lifted.*

### Closing the Platform

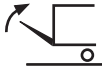

- ▶ Press the pushbuttons **(27)**, **(32)** and optionally **(29)** simultaneously and hold them in this position until the platform is closed.

## F G Special Operating Elements

- 27 Pushbutton: lift/close
- 28 Pushbutton: lower/open
- 32 Pushbutton: close/open
- 29 Pushbutton: additional pushbutton
- 30 Pushbutton: extend
- 31 Pushbutton: retract

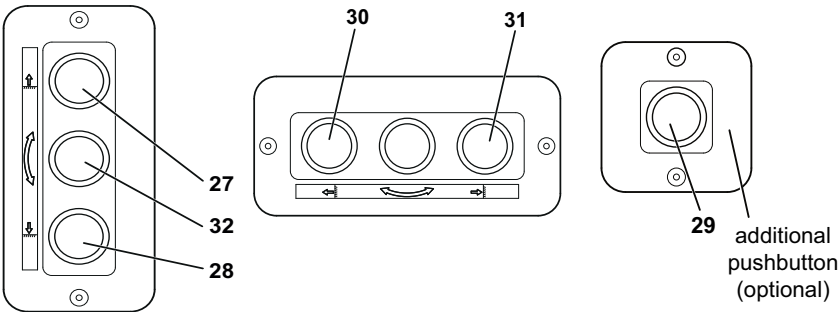

### DANGER!



#### Risk of accidents and injury!

If the instructions in chapter “General Operation” are not observed during operation of the tail lift, personal injuries and material damage can occur.

- ▶ Before operating the tail lift, read chapter “General Operation” from p. 24.

#### Lowering the Platform



- ▶ Press the pushbuttons (28) and optionally (29) simultaneously and hold them in this position until the platform has made contact with the ground.

*After the platform has touched the ground it tilts and adjusts to the ground.*

#### Lifting the Platform



- ▶ Press the pushbuttons (27) and optionally (29) simultaneously and hold them in this position until the platform has reached the vehicle loading floor height.

*The platform tilts to the horizontal or preset position before it is lifted.*

### Setting the Platform to its Horizontal Position

- ▶ To adjust a steeper tilt of the platform, press both pushbuttons **(27)**, **(32)** and optionally **(29)** simultaneously and hold them in this position until the platform has reached the required tilt angle.
- ▶ To adjust a flatter tilt of the platform, press both pushbuttons **(28)**, **(32)** and optionally **(29)** simultaneously and hold them in this position until the platform has reached the required tilt angle.

### Extending and Folding Out the Platform

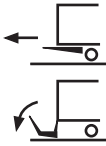

- ▶ Loosen the platform interlock (if present).
- ▶ Press the pushbuttons **(28)** and optionally **(29)** simultaneously and hold them in this position until the platform has completely lowered.  
*The platform is lowered so that it can be extended without obstruction.*
- ▶ Press the pushbutton **(30)** and hold it in this position until the platform is completely extended.
- ▶ Press the pushbuttons **(28)** and optionally **(29)** simultaneously and hold them in this position until the folded platform has made contact with the ground.
- ▶ Protect your hands with gloves.
- ▶ Pull the handle with both hands to unfold the folding part of the platform.

### Folding In and Retracting the Platform

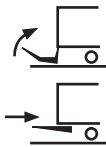

- ▶ Protect your hands with gloves.
- ▶ Pull the handle with both hands to fold back the folding part of the platform.
- ▶ Close the platform interlock (if present).
- ▶ Press the pushbuttons **(27)** and optionally **(29)** simultaneously and hold them in this position until the platform has reached the retraction height.
- ▶ Press the pushbutton **(31)** and hold it in this position until the platform is completely retracted. Make sure that the platform can be retracted without obstruction.
- ▶ Press the pushbuttons **(27)** and optionally **(29)** simultaneously and hold them in this position until the platform has reached the vibration safeguard.

## A C E K L Special Operating Elements

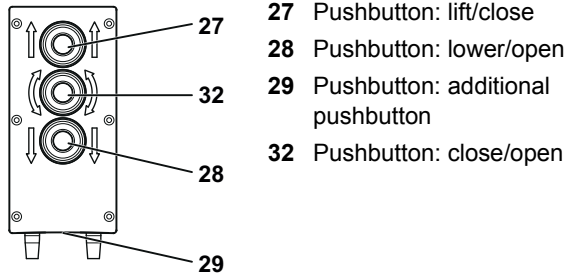

- 27 Pushbutton: lift/close
- 28 Pushbutton: lower/open
- 29 Pushbutton: additional pushbutton
- 32 Pushbutton: close/open

### DANGER!



#### Risk of accidents and injury!

If the instructions in chapter “General Operation” are not observed during operation of the tail lift, personal injuries and material damage can occur.

- ▶ Before operating the tail lift, read chapter “General Operation” from p. 24.

#### Opening the Platform



- ▶ Loosen the platform interlock (if present).
- ▶ Press the pushbuttons **(28)**, **(32)** and **(29)** simultaneously and hold them in this position until the platform has reached the horizontal operating position.

#### Lowering the Platform



- ▶ Press the pushbuttons **(28)** and **(29)** simultaneously and hold them in this position until the platform has made contact with the ground.

*After the platform has touched the ground it tilts and adjusts to the ground.*

#### Lifting the Platform



- ▶ Press the pushbuttons **(27)** and **(29)** simultaneously and hold them in this position until the platform has reached the vehicle loading floor height.

*The platform tilts to the horizontal or preset position before it is lifted.*

#### Closing the Platform



- ▶ Press the pushbuttons **(27)**, **(32)** and **(29)** simultaneously and hold them in this position until the platform is closed.

All Models

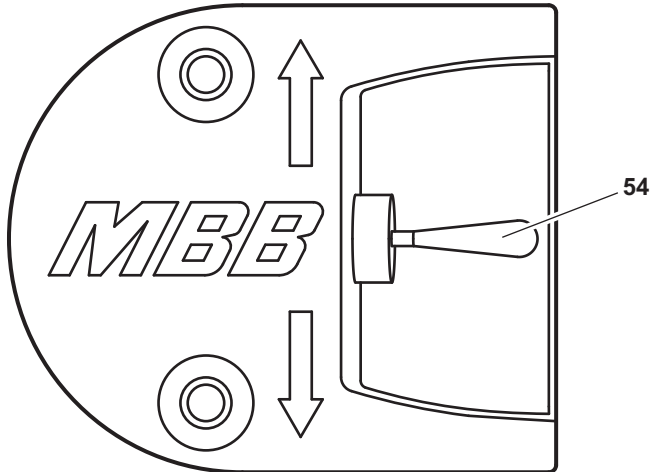
**Special Operating Elements for Hydraulic Stabilizer Feet****54** Toggle switch**DANGER!****Risk of accidents and injury!**

If the instructions in chapter “General Operation” are not observed during operation of the tail lift, personal injuries and material damage can occur.

- ▶ Before operating the tail lift, read chapter “General Operation” from p. 24.

**Extending the Hydraulic Stabilizer Feet**

- ▶ Push down the toggle switch (**54**) until the stabilizer feet are extended almost to the ground.

**Retracting the Hydraulic Stabilizer Feet**

- ▶ Push up the toggle switch (**54**) until the stabilizer feet are completely retracted.

## A Programming a Key Code

- ▶ You can switch on the tail lift by a key code. The factory setting is:

Key (Combination) to be Pressed		
Lift	Close	Lift
3 x	3 x	3 x

To change this key code:

- ▶ Open the platform.
- ▶ Bring down the platform until it is adjusted flush to the ground.
- ▶ Open the sealing cap of the support tube (on the right, as seen in direction of travel) or open the cover of the hydraulic unit.
- ▶ Disconnect plug J 30.
- ▶ Switch off the electrical equipment.
- ▶ Connect the contacts J 30/5, 6, 14, 3 with contact 4 (service plug).
- ▶ Switch on the electrical equipment.

*The tail lift is now in programming mode.*

- ▶ Disconnect the service plug and connect plug J 30 at the lateral operating element.
- ▶ Enter the desired code at the lateral operating element as follows:

Key (Combination) to be Pressed		
Lift	Close	Lift
x-times	x-times	x-times

*Each key actuation switches on the warning lights.*

*If your entry has been correct, the programming mode is automatically left. You can continue to operate your tail lift as usual.*

*If your entry was faulty, the warning lights briefly flash 5 times. You have to enter the code again.*

## Clearing the Service Counter (Maintenance Counter)

After 5000 cycles (lifts) the tail lift should be serviced. The control box will flash for 2 seconds with high frequency after switch-on to indicate that this limit value is reached. Proceed as described below to clear the service counter after this.

- ▶ Close the platform, but leave the control box switched on.
- ▶ Disconnect plug J 11.
- ▶ Disconnect plug J 30.
- ▶ Connect the service plug.
- ▶ Connect plug J 11.

*The service counter is cleared.*

- ▶ Disconnect the service plug.
- ▶ Connect plug J 30.
- ▶ Disconnect plug J 11 and connect it again.

*This switches the tail lift back into operating mode.*

**Note:** You can also reset the service counter by using the diagnostic software.

## Troubleshooting

This function is only available for special program versions. For more information please contact our customer service. Proceed as follows to troubleshoot the tail lift:

- ▶ Switch on the control box.
- ▶ Open the platform so that it is in horizontal position.
- ▶ Disconnect plug J 11.
- ▶ Disconnect plug J 30.
- ▶ Connect the service plug.
- ▶ Connect plug J 11.
- ▶ Disconnect the service plug.
- ▶ Connect plug J 30.

*Every connected input is now indicated by continuous warning lights.*

*If your tail lift is not equipped with Warnfix, you have to connect a test lamp to PIN 7 of plug J3.*

- ▶ Disconnect plug J 11 and connect it again.

*This switches the tail lift back into operating mode.*

**Note:** You can also troubleshoot your tail lift by using the diagnostic software.

## Error Recognition by Using the 7-Segment Display

This function is only available with MBB Control.

<b>Status indication</b> (7 segments, static, System LED flashing green (2 Hz))	
Status	Description
Status 0 =>	System switched on and all right, control box switched off
Status 1 =>	System switched on and all right, control box switched on

<b>Error indication</b> (7 segments, flashing (0.5 Hz), System LED flashing red (2 Hz))		
Status	Description	Action for error reset
Error 2 =>	Undervoltage	Switch off/on control box
Error 3 =>	On lift arms switch (B13): On signal although tail lift is closed -> Short-circuit on B13 With MBB Control Eco -> lift arms switch B16 defective	Automatic error reset as soon as correct values are reached
Error 4 =>	Lift arms tilt sensor (B15): Faulty sensor signal	
Error 5 =>	Head tilt sensor (B15): Faulty sensor signal	
Error 6 =>	Warnfix: short-circuit recognized	Switch control box off/on or close tail lift
Error 7 =>	Box body light/control box LED: short-circuit recognized	
Error 8 =>	General short-circuit error of external system	Switch control box off/on or de-energize PC board

<b>Valve coil monitoring</b> (not available for all models)		
Status	Description	Action for error reset
Error 9 =>	While lifting the platform, the "motor relay coil resistance" error was detected.	Automatic error reset as soon as correct values are reached
Error "a" =>	Not used or reserved	
Error "b" =>	While opening the platform, the "valve coil resistance open S3_S4" or "motor relay resistance" error has been detected	
Error "c" =>	While closing the platform, the "motor relay resistance" or "S5" error was detected.	Automatic error reset as soon as correct values are reached
Error "d" =>	While lowering the platform, the "valve coil resistance lower_S1_S2" error has been detected	

<b>Service functions</b> <i>(not available for all models)</i>		
<b>Status</b>	<b>Description</b>	<b>Action for disabling</b>
<b>Error "A" =&gt;</b>	<b>No voltage at J1/2 -&gt; Check fuse.</b>	<b>Automatic error reset as soon as voltage is present at J1/2.</b>
<b>Error "E" =&gt;</b>	<b>Emergency program, sensor system being bridged. Re-enable by pressing and holding "Open" and "Lower" push-buttons for more than 10 seconds.</b>	<b>Switch off/on control box</b>
<b>Error "P" =&gt;</b>	<b>Error diagnosis of all inputs is active. Warnfix is activated upon each push-button actuation.</b>	<b>Remove service plug</b>

## Service and Maintenance

### DANGER!



#### Risk of accidents and injury!

If the instructions in chapter “General Operation” are not observed during maintenance or service of the tail lift or column lift, personal injuries and material damage can occur.

- ▶ Before working on the tail lift or column lift, read chapter “General Operation” from p. 24.

### A B C F G K L M

### Maintenance Intervals

Activity	Daily	Depending on Usage	Monthly	Quarterly	Semi-annually	Annually
Checking the function and presence of the safety and warning devices	X					
Cleaning the tail lift		X				
Checking the battery		X				
Checking the carbon brushes at the electric motor		X				
Checking the oil level and refilling oil, if necessary			X			
Checking the bolts and nuts for tight seat			X			
Checking the screw fittings and pipes of the hydraulic system						X
Lubricating the low-maintenance bearings		X				
Changing the oil						X
Applying wax spray to the PC board		X				
Checking if the marks on the platform for the payload center of gravity and the operator position (when operating the tail lift or column lift with the hand cable control) are readable and in a good condition. Refreshing the marks using an abrasion-resistant paint, if required.		X				

Activity	Daily	Depending on Usage	Monthly	Quarterly	Semi-annually	Annually
For retractable tail lifts: Cleaning and lubricating guide rails		X				
If unused for more than 3 months: Moving (open, lower, lift, close) tail lift several times				X		

## E Maintenance Intervals

Activity	Daily	Depending on Usage	Monthly	Quarterly	Semi-annually	Annually
Checking the function and presence of the safety and warning devices	X					
Cleaning the tail lift		X				
Checking the battery		X				
Checking the bolts and nuts for tight seat			X			
Lubricating the low-maintenance bearings		X				
Checking the bellows			X			
Applying wax spray to the PC board		X				
Checking if the marks on the platform for the payload center of gravity and the operator position (when operating the tail lift or column lift with the hand cable control) are readable and in a good condition, refreshing the marks using an abrasion-resistant paint, if required		X				
If unused for more than 3 months: Moving (open, lower, lift, close) tail lift several times				X		

Depending on the frequency of use and external influences, the maintenance intervals can be shorter.

## V Maintenance Intervals

### DANGER!



#### Risk of accidents and injury!

When executing any maintenance or service work under the platform of the column lift, there is a risk of personal injury or property damage if the platform is not secured properly.

- ▶ Always secure the platform slide or platform against moving downwards.

Activity	Daily	Depending on Usage	Monthly	Quarterly	Semi-annually	Annually
Checking the function and presence of the safety and warning devices	X					
Cleaning the column lift		X				
Cleaning and lubricating the sliding surface of the slider in the frame					X	
Checking the battery		X				
Checking the carbon brushes at the electric motor		X				
Checking the oil level and refilling oil, if necessary			X			
Checking the bolts and nuts for tight seat			X			
Checking the screw fittings and pipes of the hydraulic system						X
Lubricating the low-maintenance bearings		X				
Changing the oil						X
Applying wax spray to the PC board		X				
Checking the mark for the payload center of gravity for good readability; refreshing mark with abrasion-resistant paint if required		X				
If unused for more than 3 months: Moving (open, lower, lift, close) tail lift several times				X		

## All Models Maintenance Before Starting

### Checking the Safety and Warning Devices

The safety devices of the tail lifts comply with the respective current version of the valid regulations.

- ▶ Before starting to drive, check whether all safety and warning devices are operational.
- ▶ Renew any damaged and non-operational safety and warning devices.

Depending on the model, the safety and warning devices comprise:

- non-slip platform surface
- roll-off protection on the platform (optional)
- holding grip for the accompanying operator (not in scope of delivery of the tail lift)
- warning flashers on the platform
- warning flags behind the platform
- platform interlock at the platform (optional)
- two-feet control for “lift” and “lower” on the platform
- key control at lateral operating element for trailers or semi-trailers
- control box with ON/OFF switch in lockable driver's cab
- optical signal at control box in driver's cab for tail lift “ON” and/or platform open
- stop valves on lift and tilt cylinders to prevent line break (except model E)
- flow valves for limiting the lowering and opening speed (except model E)

## Maintenance Depending on Usage Frequency

### All Models

#### Cleaning the Tail Lift

#### CAUTION!



#### Damage to paint!

If you clean the tail lift using a pressure washer, damage to the paint may occur up to six weeks after painting.

- ▶ Cleaning the tail lift with a pressure washer should not be done earlier than six weeks after painting.

The following parts of the tail lift may not be cleaned with a pressure washer:

- piston rods and cylinder seals
- lateral operating element
- solenoid valves (except model E)
- foot control
- warning lights and warning flags
- Bellows

### All Models

#### Checking the Battery

- ▶ Service the battery in the usual way.

### A B C F G K L M V

#### Checking the Carbon Brushes at the Electric Motor

#### CAUTION!



#### Risk of burns by overheating electric motor!

Worn out and contaminated carbon brushes can result in increased current consumption. This can cause the electric motor to overheat.

- ▶ Occasionally clean the carbon brushes.
- ▶ Contact a service engineer or a contractor repair shop to have worn out or contaminated carbon brushes replaced.

- ▶ Occasionally check the carbon brushes of the electric motor in the hydraulic unit and clean them to remove the carbon dust.

**All Models****Applying Wax Spray to the PC Board**

To protect the contacts against corrosion.

- ▶ Depending on the weather conditions and especially after exposure to salt water spray, apply wax spray to the PC board and the connector plugs.

**Greasing and Lubricating**

- ▶ Grease the conical lubricating head as required and after each cleaning with a pressure washer.

**Checking/Refreshing Platform Marks**

The marks on the platform must always be in a good condition and clearly visible. They indicate the payload center of gravity and the operator position on the platform when operating the tail lift by using the hand cable control.

- ▶ Check the marks for good visibility and refresh them if required with abrasion-resistant paint.

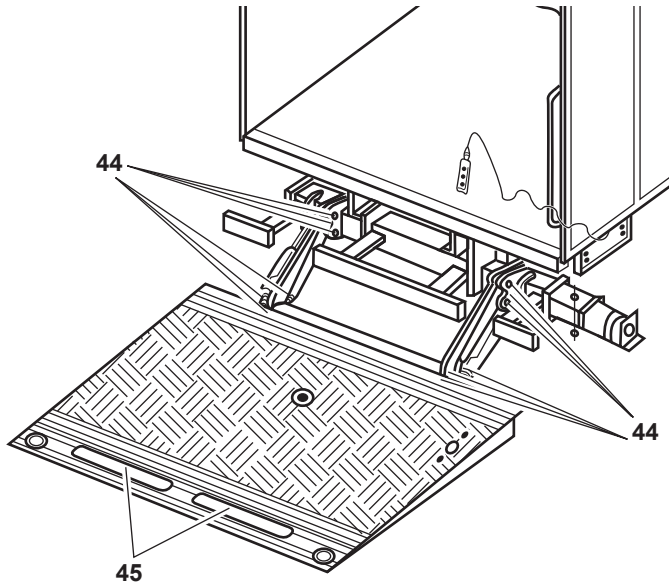
**A B C E** Standard Models (Upright Platform)

**44** Conical lubricating heads (grease nipples)

**45** Roll-off protection bearings

To grease and lubricate:

- ▶ Clean the conical lubricating heads.
- ▶ Use a grease gun to press grease into the conical lubricating heads (**44**) until the bearing is filled (see chapter “Lubricants and Operating Media” from p. 178).
- ▶ Lubricate the bearings of the roll-off protection (**45**) (see chapter “Lubricants and Operating Media” from p. 178).

## FG Retractable Models

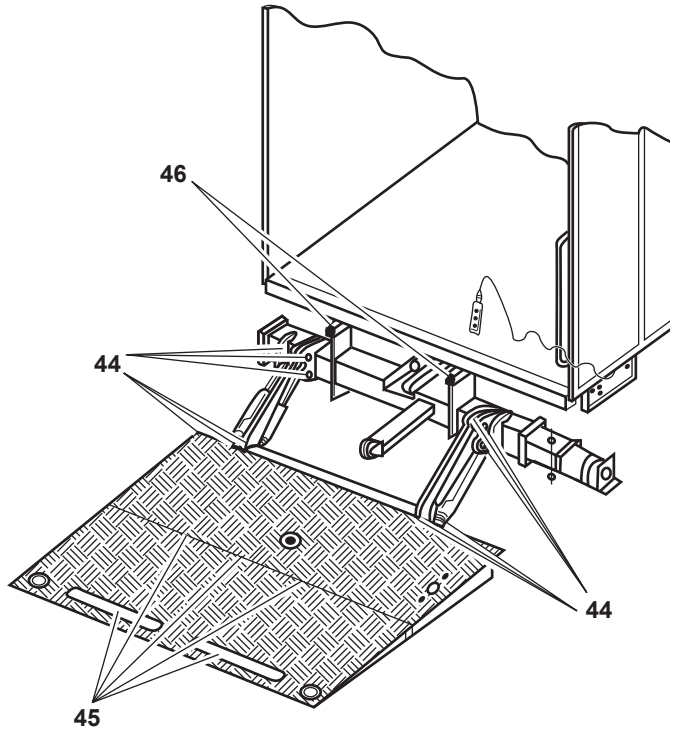

- 44** Conical lubricating head
- 45** Roll-off protection bearings and joint of folding platform
- 46** Sliding consoles in the guide rails (nozzle lubrication)

To grease and lubricate:

- ▶ Clean the conical lubricating heads.
- ▶ Use a grease gun to press grease into the conical lubricating heads (**44**) until the bearing is filled (see chapter "Lubricants and Operating Media" from p. 178).
- ▶ Lubricate the bearings of the roll stop and the joint in the platform (**45**).
- ▶ Lubricate the sliding consoles in the guide rails (**46**) (see chapter "Lubricants and Operating Media" from p. 178).

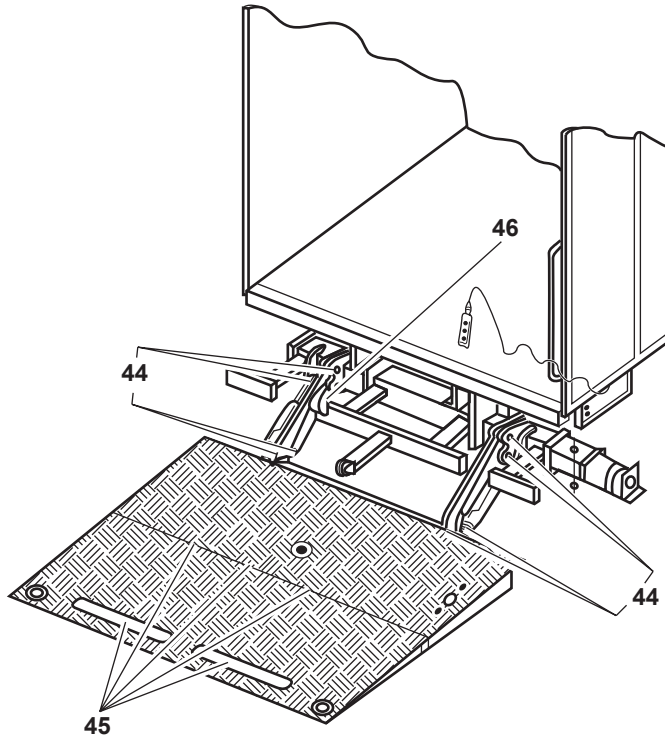
**K L M** Foldable Models

- 44** Conical lubricating head  
**45** Roll-off protection bearings and joint of folding platform  
**46** Bearings at the guide rails

To grease and lubricate:

- ▶ Clean the conical lubricating heads (**44**).
- ▶ Use a grease gun to press grease into the conical lubricating heads (**44**) until the bearing is filled (see chapter “Lubricants and Operating Media” from p. 178).
- ▶ Lubricate the bearings of the roll stop and the joint in the platform (**45**).
- ▶ Lubricate the sliding consoles in the guide rails (**46**) (see chapter “Lubricants and Operating Media” from p. 178).

## V Column Lifts

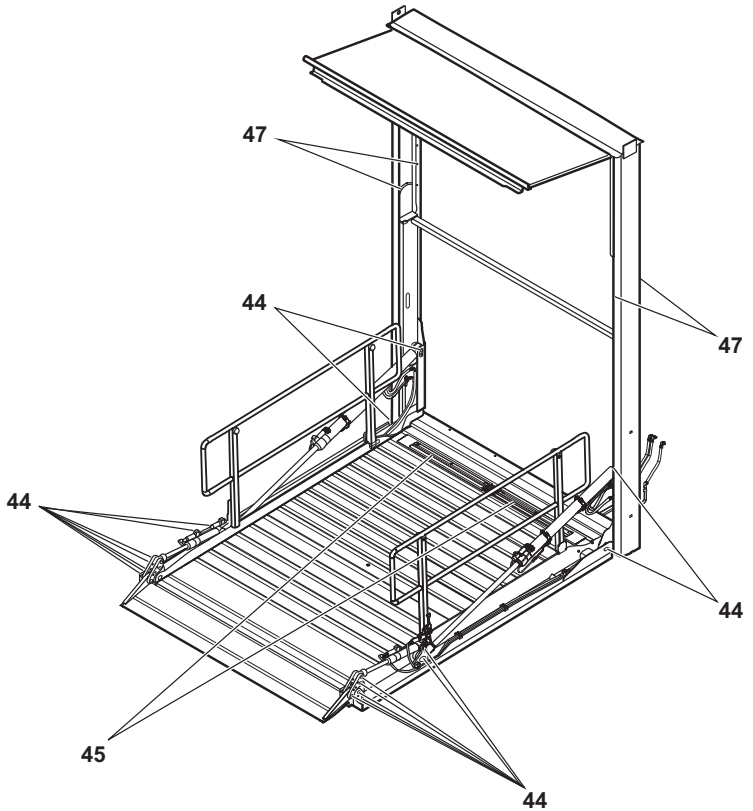

- 44** Conical lubricating head
- 45** Roll-off protection bearings
- 47** Sliding surface of the slider

To grease and lubricate:

- ▶ Clean the conical lubricating heads (**44**).
- ▶ Use a grease gun to press grease into the conical lubricating heads (**44**) until the bearing is filled (see chapter "Lubricants and Operating Media" from p. 178).
- ▶ Lubricate the bearings of the roll-off protection (**45**) (see chapter "Lubricants and Operating Media" from p. 178).
- ▶ Clean all sliding surfaces (**47**) of the slider in the guide frame and lubricate them evenly with heavy duty grease.

## Monthly Maintenance

### Checking the Oil Level

#### A B C Standard Tail Lifts

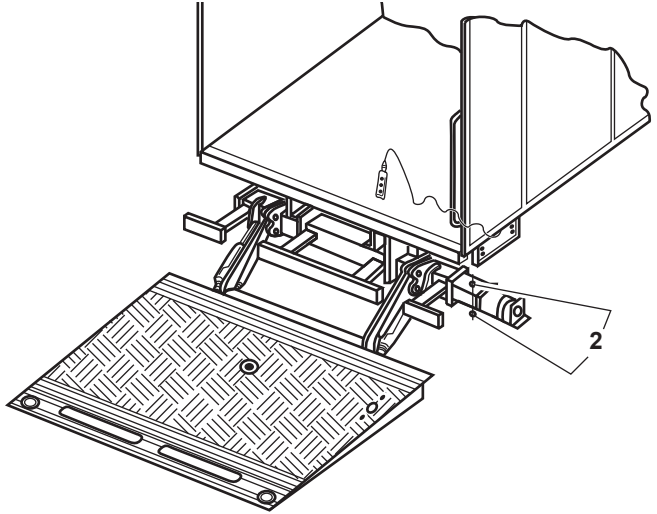

#### F G Retractable Models

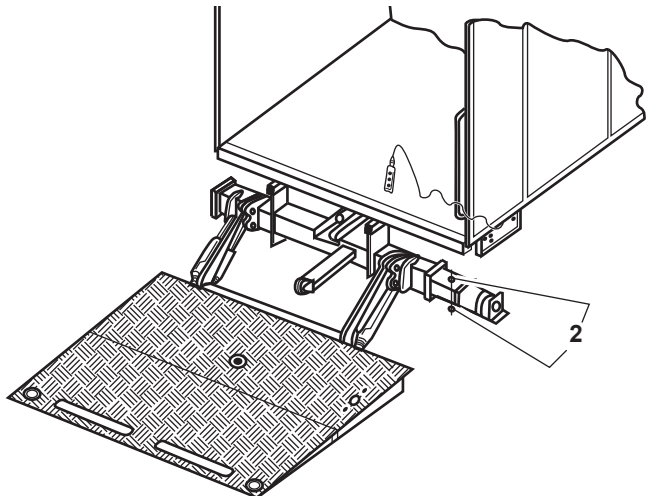

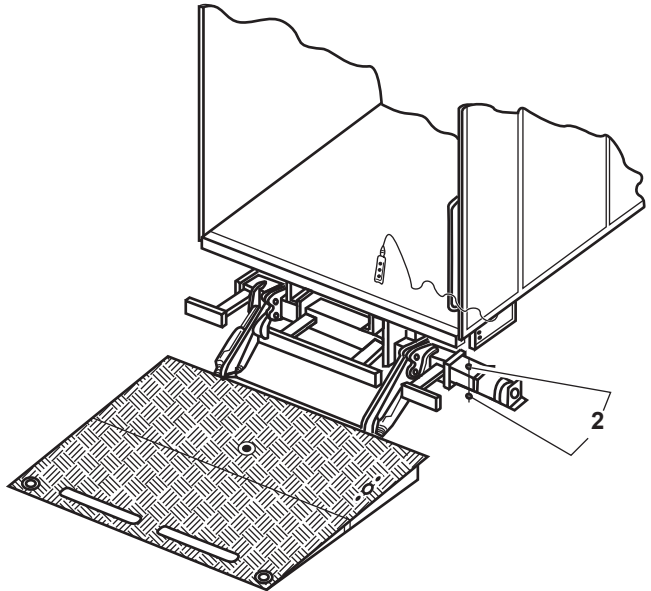
**K L M** Foldable Models**2** Hydraulic unit on support tube

**Slide-in Unit:** To check the oil level:

- ▶ Lower the tail lift so that the platform touches the ground.
- ▶ If required, retract all stabilizer feet.
- ▶ Open the right cover of the support tube.
- ▶ Loosen the fastening screw of the hydraulic unit at the support tube **(2)**.
- ▶ Pull out the hydraulic unit until the check mark at the oil reservoir is visible.
- ▶ Using the indicator at the oil reservoir or the dip stick, check whether the indication is within the prescribed marked range.
- ▶ If required, refill oil up to level mark.
- ▶ Re-insert the hydraulic unit in to the support tube and fasten it with the screw **(2)**.
- ▶ Close the cover of the support tube.

**Box-type or reversible unit:**

To check the oil level:

- ▶ Lower the tail lift so that the platform touches the ground.
- ▶ If required, retract all stabilizer feet.
- ▶ Remove the cover from the unit.
- ▶ Using the indicator at the oil reservoir or the dip stick, check whether the indication is within the prescribed marked range.
- ▶ If required, refill oil up to level mark.
- ▶ Re-install the cover of the unit.

**All Models****Checking the Bolts and Nuts for Tight Seat**

- ▶ Check whether all bolts and nuts are seated tightly.
- ▶ Especially observe all bearing pins and associated bolts and all fastening elements of the auxiliary frame and the tail lift mounting!
- ▶ Retighten any loose bolts and nut.

**ABCFGKLMV****Checking the Screw Fittings and Pipes of the Hydraulic System**

- ▶ Check all screw fittings and pipes of the hydraulic system. Make sure that the screws are tight and the hydraulic lines undamaged.
- ▶ Retighten any loose screws.
- ▶ Replace damaged hydraulic hoses immediately.
- ▶ Replace all hydraulic hoses after three years at the latest. The manufacture date is stamped on the fittings.

**All Models****Checking the Bellows**

- ▶ Make sure that the two bellows are in a good condition and undamaged and that they are tightly fit to the piston rod and cylinder.
- ▶ Replace damaged bellows immediately.

## Quarterly or Semi-annual Maintenance

### All Models

#### Lubrication of the Low-maintenance Bearings

- ▶ Clean the low-maintenance bearings.
- ▶ Grease the low-maintenance bearings with lubricant grease.

**Note:** If you use the tail lift quite frequently, the low-maintenance bearings must be greased more frequently than once a year.

#### Moving the Tail Lift

After a standstill of more than 3 months you have to move the tail lift several times.

- ▶ Open, lift, lower and close the tail lift using the corresponding operating element.
- ▶ Repeat this procedure approximately 5 times.

## Annual Maintenance

### A B C F G K L

#### Changing the Hydraulic Oil

#### CAUTION!



#### Risk of injury or material damage through waste oil!

If you do not change the oil in the hydraulic unit once a year, condensation water could accumulate, especially at temperatures below the freezing point. This disturbs the function of the tail lift. Persons could be injured and material could be damaged.

- ▶ Change the hydraulic oil once every year.
- ▶ Preferably change the oil shortly before the start of the winter season.

Slide-in Unit:

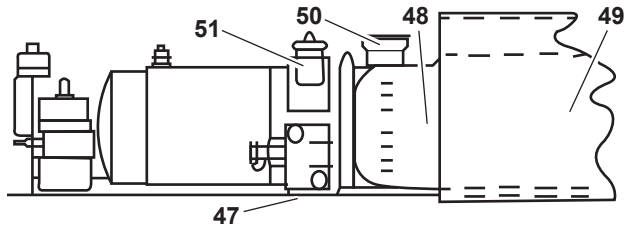

Box-type Unit:

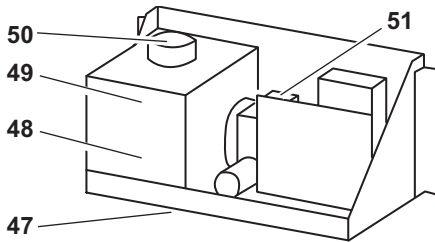

Reversible Unit

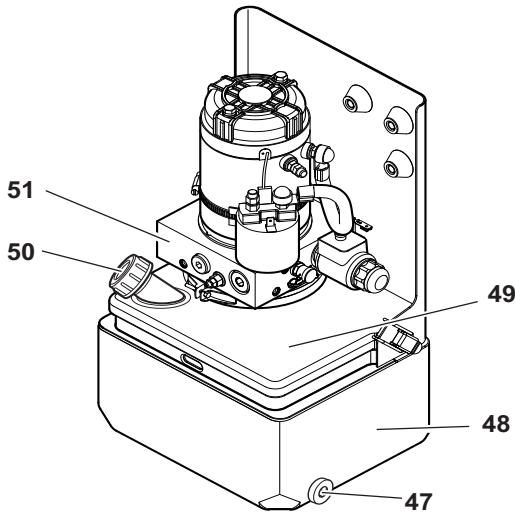

- 47 Oil drain plug
- 48 Hydraulic oil reservoir
- 49 Suction filter in the oil reservoir
- 50 Breather filter
- 51 Valve block

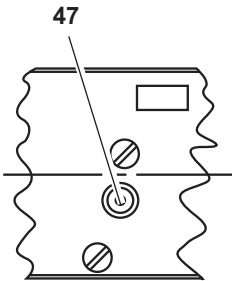

To change the hydraulic oil:

- ▶ Lower the tail lift so that the platform touches the ground (see chapter “Operating Elements” from p. 38).
- ▶ **For the slide-in unit:**  
Draw out the hydraulic unit so that the valve block (51) is positioned outside the block (see chapter “Checking the Oil Level” from p. 130).

**For the box-type or reversible unit:**

Remove the cover from the unit.

- ▶ Place a sufficiently large vessel under the oil drain plug (47).
- ▶ Loosen the oil drain plug (47) using a 6 mm hex socket wrench and drain the oil into the vessel.

If the hydraulic oil is extremely contaminated you must clean the hydraulic oil reservoir (48):

- ▶ Loosen the clamp between the hydraulic oil reservoir (48) and the valve block (51).
- ▶ Drain the oil.
- ▶ Pull off the hydraulic oil reservoir (48) from the unit and clean it outside the hydraulic unit.
- ▶ Also renew the suction filter in the oil reservoir (49) and the breather filter (50).
- ▶ Install the cleaned hydraulic oil reservoir into the unit and reinstall the oil drain plug (47).
- ▶ Fill oil according to the marking at the oil reservoir or dip stick.

**Note:** Exclusively use oils listed in the chapter “Lubricants and Operating Media” from p. 178.

- ▶ After filling the oil reservoir, run the equipment through two full working cycles.
- ▶ Check the oil level (see chapter “Checking the Oil Level” from p. 130) and refill or drain oil as required.
- ▶ **For the slide-in unit:**  
Push the hydraulic unit back into the support tube and fasten it.
- ▶ **For the box-type or reversible unit:**  
Re-install the cover of the unit.
- ▶ Dispose of the waste oil according the regulations.

## V Changing the Hydraulic Oil

### CAUTION!



#### Risk of injury or material damage through waste oil!

If you do not change the oil in the hydraulic unit once a year, condensation water could accumulate, especially at temperatures below the freezing point. This disturbs the function of the column lift. Persons could be injured and material could be damaged.

- ▶ Change the hydraulic oil once every year.
- ▶ Preferably change the oil shortly before the start of the winter season.

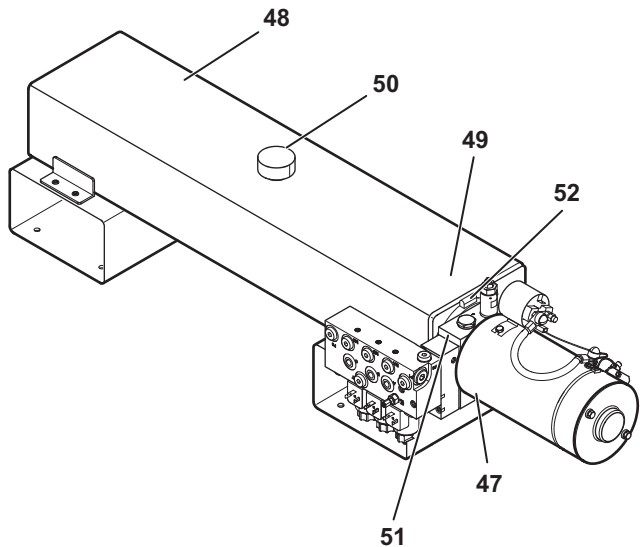

- 47 Oil drain plug
- 48 Hydraulic oil reservoir
- 49 Suction filter in the oil reservoir
- 50 Breather filter
- 51 Valve block
- 52 Clamp

To change the hydraulic oil:

- ▶ Close the platform with the link bridge folded in; as a result the entire hydraulic oil will flow into the hydraulic oil reservoir (see chapter "Operating Elements" from p. 38).
- ▶ Remove the breather filter (50).
- ▶ Suck out the hydraulic oil via the oil fill hole.

If the hydraulic oil is extremely contaminated you must clean the hydraulic oil reservoir (48):

- ▶ Remove the stop at the rear side of the oil reservoir.
- ▶ Loosen the clamp (52).
- ▶ Disconnect the hydraulic oil reservoir (48) from the valve block (51). Take care of the intake and outlet lines and the suction filter (49) in the hydraulic oil reservoir (48).
- ▶ Remove the hydraulic oil reservoir (48) from its guide and lift it off to clean it outside the vehicle.
- ▶ Re-insert and re-connect the hydraulic oil reservoir (48). Proceed as described above, but in reverse order.
- ▶ Fill oil according to the marking at the oil reservoir or dip stick. The fill level should be 2/3 of the dip stick.

**Note:**

Exclusively use oils listed in the chapter "Lubricants and Operating Media" from p. 178.

- ▶ After filling the oil reservoir, run the equipment through two full working cycles.
- ▶ Check the oil level (see chapter "Checking the Oil Level" from p. 130) and refill or drain oil as required.
- ▶ Push the hydraulic unit back into the support tube and fasten it.
- ▶ Dispose of the waste oil according the regulations.

**All Models****Protecting the Main Switch from Corrosion**

To protect the main switch with strip fuse against corrosion:

- ▶ Grease the main switch with contact grease.

**Checks**

With every tail lift a test data booklet is provided. According to this test data booklet the following checks must be performed by a specialist of your contractor repair shop:

- Check after installation, confirming the satisfactory commissioning in writing in the test data booklet.
- Periodic verification which must be performed at least once a year. The essential scope of checks is described in the test data booklet. The check must be confirmed in the test data booklet in writing.
- Extraordinary check after major repairs or structural changes. The check must be confirmed in the test data booklet in writing.

Structural changes are only allowed with the consent of the manufacturer. Any warranties shall become void if modifications at the tail lift are performed without our consent. The manufacturer shall not be held responsible for damages, accidents, etc. The same applies for the usage of third-party spare parts, if their use has not been explicitly approved.

## All Models Eliminating Faults

Faults may occur even in the best maintained and serviced tail lift.

The following description of possible faults will enable you to recognize faults quickly and eliminate them saving time and costs.

Principally, troubleshooting and the elimination of faults should be done in the contractor repair shops. In the list of repair shops you find the information how to find our contractor repair shops. If necessary, you can request the list free of charge from our sales offices or the factory.

For troubleshooting, preferably a test lamp can be used. Use the ground connector on the PC board for troubleshooting.

**Note:** If the tail lift can not be operated any more due to a defective sensor, it can be switched to an emergency operating mode. In the emergency operating mode the sensors are not called up. Proceed as described below to switch to the emergency operating mode:

- ▶ Press the pushbuttons "Open", "Lower" and if there is, the "Additional Key" for at least 10 seconds.

*In the 7-Segment Display an "E" appears. Now each tail lift movement has to be ordered manually. All the automatic processes are deactivated.*

Before troubleshooting, check the following:

- ▶ Make sure that the tail lift is switched on in the driver's cab.
- ▶ Check whether the battery main switch is switched on.
- ▶ Make sure that the main fuse for the power supply is intact.
- ▶ Check the two control-circuit fuses of the hydraulic unit or power unit for correct function.
- ▶ Check the control voltage fuse for 12 V systems at the vehicle battery for correct function.
- ▶ Make sure that the vehicle batteries function correctly and are charged.
- ▶ Verify that the ground cable on the hydraulic unit or power unit establishes a good connection between the tail lift and the vehicle.

- ▶ Make sure that the oil reservoir is sufficiently filled (except model E).
- ▶ Check that mechanical or electrical components, for example cables, are not damaged.

**WARNING!****Risk of burns in case of short-circuits!**

Serious burns can occur in case of a short-circuit of the high-power batteries.

- ▶ Before starting any work at the electric system, disconnect the battery main switch or disconnect the negative lead from the battery.

If more faults occur in the tail lifts you should not try to eliminate the faults yourself, but by contractor repair shops and with the aid of the following tables. The list of repair shops shows you the nearest repair shop and provides further contact information.

## **A C F G K L M Troubleshooting Tables**

<b>Before switching on</b>		
<b>Fault</b>	<b>Possible cause</b>	<b>Remedy</b>
Optical indication in driver's cab flashes rapidly	Tilt sensor b15 defective	Replace tilt sensor b15

<b>Switching on</b> (LED on PC board flashes with the same rate as the turn signal)		
<b>Fault</b>	<b>Possible cause</b>	<b>Remedy</b>
Optical indication in driver's cab flashes furiously	Lift arms switch b13 defective (short-circuit)	Replace lift arms switch b13
	Tilt sensor b15 guide rod defective	Replace tilt sensor b15
LED on PC board does not flash	ON/OFF switch in driver's cab defective	Check connections 2 and 4 with test lamp
	Fuses in unit e1 or e2 have tripped	Replace fuses
	PC board in sealing cover defective	Replace PC board

 <b>Open</b> (Platform opens to the horizontal operating position – this position is stored and moved to after the ground adjustment during lifting)		
<b>Fault</b>	<b>Possible cause</b>	<b>Remedy</b>
Platform does not open with motor	No signal at output J 1/3	Use test lamp to check according to circuit diagram
	Motor contactor defective	Check motor contactor
Platform does not open	Rotary switches, pushbuttons, or toggle switches defective	Use test lamp to check contacts in operating element according to circuit diagram, use ground connection JK at PC board
	No voltage at valve plug S 3 or S 4, defective cable	Check with test lamp
	Control valve S 5 or pressure splitter stuck	Clean or replace

**Open**

(Platform opens to the horizontal operating position – this position is stored and moved to after the ground adjustment during lifting)

Fault	Possible cause	Remedy
Warning lamps on platform are not flashing when platform is open	Tilt sensor b15 at the platform misadjusted or defective	Adjust or replace
	PC board defective	Replace
	Plugs defective	Replace
	Warning lamps defective	Replace
	Initiator b25 misadjusted or defective	Adjust or replace

**Extend**

Fault	Possible cause	Remedy
Platform does not extend, motor is running	Solenoid valves S 7 and S 8 leaking	Clean or replace
	Solenoid valve S 8 does not open	Clean or replace
	Lowering brake valve S 11 does not open	Clean or replace
	Piston seal in guide cylinder defective	Replace

**Fold out**

(model MBB R 1500 SH – R 2000 LH)

Fault	Possible cause	Remedy
Platform does not unfold, motor is running	Solenoid valves S 7 and S 8 leaking	Clean or replace
	Solenoid valve S 12 does not open	Clean or replace
	Valve S 10 does not open	Clean or replace
	Piston seal in folding cylinder defective	Replace

 <b>Lower</b>		
<b>Fault</b>	<b>Possible cause</b>	<b>Remedy</b>
Platform does not come down or too slowly, but opening operation works	Flow valve R 1 or R 2 at lift cylinder stuck or defective	Clean or replace
	Seating too tight	Grease all seating points
	Hydraulic oil too thick	Change oil, use oil grade as recommended
Platform does not come down when operated with foot controls	The foot controls were actuated too fast (less than 1 s) or too slow (more than 3 s) after each other	Release both foot controls, wait a few seconds, and repeat procedure
	Foot control defective	Disconnect plug connection in the platform, check foot controls with continuity tester
	Cable no. 2 to platform defective	Actuate both foot controls and check the voltage at plugs J 3/6 and J 3/5 on the PC board using a test lamp
Platform does not come down when operated with lateral operating element	Rotary switches, pushbuttons, or toggle switches defective	Use test lamp to check contacts in operating element according to circuit diagram, use ground connection JK at PC board
	PC board does not deliver output at J 4/15	Disconnect plug J 4, check terminal 15 with test lamp
	PC board does not deliver output at J 1/12	Disconnect plug J 1, check terminal 12 with test lamp
	No voltage at valve plug S 1 or S 2, defective cable	Check with test lamp
	Valve S 5 in unit does not switch on	Check with test lamp
Platform tilts during lowering	Lift arms switch b13 misadjusted	Adjust
Platform tilts automatically	Solenoid valves S 3 and S 4 at tilt cylinder contaminated or defective	Clean or replace
	Piston seal in tilt cylinder defective	Replace
Platform comes down automatically	Solenoid valves S 1 and S 2 at lift cylinder contaminated or defective	Clean or replace

 <b>Ground adjustment</b> (platform tilts)		
Fault	Possible cause	Remedy
<b>Emergency actuation:</b> Actuate "Open" (28) pushbutton and additional pushbutton (29) on lateral control element until platform tilts		
Platform does not tilt	Lift arms switch b13 misadjusted or defective	Adjust lift arms switch b13 so that the platform tilts after touching the ground
	PC board does not deliver output at J 4/14	Check at connection b1 (signal) of plug J 41 (lift arms switch) with test lamp
	No voltage at valve plug S 3 or S 4, defective cable	Disconnect plug J 4, check terminal 14 with test lamp
	Solenoid valves S 3 and S 4 at tilt cylinder contaminated or defective	Clean or replace
	PC board has stored error	De-energize, check with test lamp
	Flow valve R 5 or pressure splitter stuck or defective	Clean or replace
	PC board defective	Replace
Platform does not tilt, optical indicator in driver's cab flashes rapidly	Tilt sensor b15 guide rod defective	Replace tilt sensor b15

 <b>Lift platform off the ground</b> (platform tilts into the horizontal operating position that was stored when it was opened)		
Fault	Possible cause	Remedy
Platform does not tilt into the horizontal operating position when operated via foot controls	The foot controls were actuated too fast (shorter than 1 s) or too slow (longer than 3 s) after each other	Release both foot controls, wait a few seconds, and repeat procedure
	Foot control defective	Disconnect plug connection in the platform, check foot controls with continuity tester
	Cable no. 2 to platform defective	Actuate both foot controls and check the voltage at plugs J 3/6 and J 3/5 on the PC board using a test lamp
Platform does not tilt into the horizontal position when lifting	Directional valve S 5 stuck or defective	Clean or replace
	Tilt sensor b15 defective	Replace
Platform tilts further than the preset angle	Tilt sensor b15 defective	Replace
	Directional valve S 5 stuck or defective	Clean or replace
Platform does not tilt into the horizontal operating position but is lifted	PC board does not deliver output at J 1/12	Check plug J 1 terminal 12 with test lamp, use ground connection JK of the PC board
	Valve S 5 in unit does not switch on	Check with test lamp
Platform does not tilt into the horizontal operating position, but is lifted, optical indicator in driver's cab flashes rapidly	Tilt sensor b15 platform defective	Replace tilt sensor b15
Platform tilts further than the preset angle when the platform is lifted	Tilt sensor b15 defective	Replace
	Directional valve stuck or defective	Clean or replace

 <b>Lift</b> (platform moves up to loading edge)		
Fault	Possible cause	Remedy
Platform does not lift up	Rotary switches, pushbuttons, or toggle switches defective	Use test lamp to check contacts in operating element according to circuit diagram, use ground connection JK at PC board
	PC board does not deliver output at J 1/3	Check PC board according to circuit diagram at plug J 1/3 with test lamp
	Motor contactor in unit does not switch on or is defective	Check motor contactor with test lamp
Platform is not lifted up although hydraulic unit is running	Directional valve S 5 stuck or defective	Clean or replace
	Solenoid valves S 1 and S 2 at lift cylinder contaminated or defective	Clean or replace
	Suction filter at pump contaminated	Clean or replace
	Platform overloaded	Reduce load according to load diagram
	Hydraulic pump defective	Replace
	Electric motor defective	Replace
	Pressure splitter contaminated or defective	Clean or replace
	Pressure relief valve misadjusted or defective	Adjust and lock the valve or replace it

 <b>Close</b> (platform closes)		
Fault	Possible cause	Remedy
Platform does not close	Rotary switches, pushbuttons, or toggle switches defective	Check contacts in operating element according to circuit diagram using test lamp
	PC board does not deliver output at J 1/3 or J 1/1	Check PC board according to circuit diagram at plug J 1/3 and 1/12 with test lamp
	Motor contactor or valve S 5 in unit do not switch on	Check with test lamp
In its closed end position the platform does not reach the vehicle loading floor height	End of box insufficiently reinforced	Reinforce box according to the details in assembly drawing
	Bearings worn out (after longer usage)	Replace bearing pins, bearing bushes

 <b>Retract</b>		
Fault	Possible cause	Remedy
Platform does not retract, motor is running	Solenoid valves S 7 and S 8 leaking	Clean or replace
	Solenoid valve S 7 does not open	Clean or replace
	Solenoid valve S 11 does not open	Clean or replace
	Piston seal in guide cylinder defective	Replace

 <b>Fold in</b> (for model MBB R 1500 SH – R 2000 LH)		
Fault	Possible cause	Remedy
Platform does not unfold, motor is running	Solenoid valves S 7 and S 8 leaking	Clean or replace
	Solenoid valve S 12 does not open	Clean or replace
	Solenoid valve S 9 does not open	Clean or replace
	Piston seal in folding cylinder defective	Replace

<b>Switch on warning light</b> (warning light is automatically switched on when the platform is opened or extended, left and right lights are switched in parallel)		
Fault	Possible cause	Remedy
Warning lamps are not flashing	Short-circuit in lamp or cabling	Repair short-circuit
	Lamp defective	Replace
	Initiator b25 defective	Replace

## E Troubleshooting Tables

Before switching on		
Fault	Possible cause	Remedy
Optical indication in driver's cab flashes rapidly	Tilt sensor b15 defective	Replace tilt sensor b15

Switching on (LED on PC board flashes with the same rate as the turn signal)		
Fault	Possible cause	Remedy
Optical indication in driver's cab flashes furiously	Lift arms switch b13 defective (short-circuit)	Replace tilt sensor b15
	Tilt sensor b15 guide rod defective	Replace tilt sensor b15
LED on PC board does not flash	ON/OFF switch in driver's cab defective	Check connections 2 and 4 with test lamp
	Fuses in power unit e1 or e2 have tripped	Replace fuses
	PC board in sealing cover defective	Replace PC board

 <b>Open</b> (Platform opens to the horizontal operating position – this position is stored and moved to after the ground adjustment during lifting)		
Fault	Possible cause	Remedy
Platform does not open	Rotary switches, pushbuttons, or toggle switches defective	Use test lamp to check contacts in operating element according to circuit diagram, use ground connection JK at PC board
	Motor contactor -K4 or relay -K5 defective	Check motor contactor and relay
	Output J4/14, JK or J43/90 does not deliver output signal	Use test lamp to check according to circuit diagram
Warning lights on platform are not flashing when platform is open	Tilt sensor b15 at the platform misadjusted or defective	Adjust or replace
	PC board defective	Replace
	Plugs defective	Replace
	Warning lamps defective	Replace

 <b>Lower</b>		
Fault	Possible cause	Remedy
Platform does not lower, but can be opened	Lift cylinder is stuck	Briefly press Lift pushbutton, then press Lower pushbutton again
	Seating too tight	Grease all seating points
	Output J4/15 or J42/81 does not deliver output signal	Use test lamp to check according to circuit diagram
	Motor contactor -K2 or relay -K7 defective	Check motor contactor and relay
Platform does not come down when operated with foot controls	Foot controls were actuated too fast (shorter than 1 s) or too slow (longer than 3 s) after each other	Release both foot controls, wait a few seconds, and repeat procedure
	Foot control defective	Disconnect plug connection in the platform, check foot controls with continuity tester
	Cable no. 2 to platform defective	Actuate both foot controls and check the voltage at plugs J 3/6 and J 3/5 on the PC board using a test lamp
Platform does not come down when operated with lateral operating element	Rotary switches, pushbuttons, or toggle switches defective	Use test lamp to check contacts in operating element according to circuit diagram, use ground connection JK at PC board
	Cable no. 3 to operating element defective	Actuate rotary switches one after another and check voltage across connector J30 according to circuit diagram using a test lamp
Platform tilts during lowering	Lift cylinder lowers too slowly or not at all	Lubricate bearings, briefly actuate Lift pushbutton, then press Lower pushbutton again

 <b>Ground adjustment</b> (platform tilts)		
Fault	Possible cause	Remedy
<b>Emergency actuation:</b>		
Actuate "Open" (28) pushbutton and additional pushbutton (29) on lateral control element until platform tilts		
Platform does not tilt	Output J4/15, J4/14, JK or J42/81 does not deliver output signal	Use test lamp to check according to circuit diagram
	Seating too tight	Grease all seating points
Platform does not tilt, opt. indicator in driver's cab flashes rapidly	Tilt sensor b15 guide rod defective	Replace tilt sensor b15

 <b>Lift platform off the ground</b> (platform tilts into the horizontal operating position that was stored when it was opened)		
Fault	Possible cause	Remedy
Platform does not tilt into the horizontal operating position when operated via foot controls	The foot controls were actuated too fast (shorter than 1 s) or too slow (longer than 3 s) after each other	Release both foot controls, wait a few seconds, and repeat procedure
	Foot control defective	Disconnect plug connection in the platform, check foot controls with continuity tester
	Cable no. 2 to platform defective	Actuate both foot controls and check the voltage at plugs J 3/6 and J 3/5 on the PC board using a test lamp
When being lifted, the platform does not tilt to its horizontal position or tilts beyond the pre-set position	Tilt sensor b15 defective	Replace
Platform does not tilt into the horizontal operating position but is lifted	Output J43/90, J1/12, JK or JK does not deliver output signal	Use test lamp to check according to circuit diagram
	Motor contactor -K3 is defective	Check motor contactor
Platform does not tilt into the horizontal operating position, but is lifted, optical indicator in driver's cab flashes rapidly	Tilt sensor b15 platform defective	Replace

 <b>Lift</b> (platform moves up to loading edge)		
Fault	Possible cause	Remedy
Platform does not lift up	Rotary switches, pushbuttons, or toggle switches defective	Use test lamp to check contacts in operating element according to circuit diagram, use ground connection JK at PC board
	PC board does not deliver output at J 1/3 or J 42/81	Use test lamp to check PC board according to circuit diagram
	Motor contactor -K1 defective	Check motor contactor

 <b>Close</b> (platform closes)		
<b>Fault</b>	<b>Possible cause</b>	<b>Remedy</b>
<b>Platform does not close</b>	<b>Rotary switches, pushbut- tons, or toggle switches de- fective</b>	<b>Use test lamp to check con- tacts in operating element ac- cording to circuit diagram, use ground connection JK at PC board</b>
	<b>PC board does not deliver output on J 1/12, J43/90 or JK</b>	<b>Use test lamp to check PC board according to circuit di- agram</b>
	<b>Motor contactor -K1 defective</b>	<b>Check motor contactor</b>
<b>In its closed end position the platform does not reach the vehicle loading floor height</b>	<b>End of box insufficiently rein- forced</b>	<b>Reinforce box according to details in assembly drawing</b>
	<b>Bearings worn out (after lon- ger usage)</b>	<b>Replace bearing pins, bear- ing bushes</b>

<b>Switch on Warnfix</b>		
<b>(Warnfix is automatically switched on when the platform is opened or extended, left and right lights are switched in parallel)</b>		
<b>Fault</b>	<b>Possible cause</b>	<b>Remedy</b>
<b>Warning light does not flash</b>	<b>Short-circuit in lamp or ca- bling</b>	<b>Repair short-circuit</b>
	<b>Lamp defective</b>	<b>Replace</b>

## V Troubleshooting Tables

Before switching on		
Fault	Possible cause	Remedy
Optical indication in driver's cab flashes rapidly	Tilt sensor b15 defective	Replace tilt sensor b15

Switching on (LED on PC board flashes with the same rate as the turn signal)		
Fault	Possible cause	Remedy
LED on PC board does not flash	Fuses in unit e1 or e2 have tripped	Replace fuses
	PC board in sealing cover defective	Replace PC board

 <b>Open</b> (platform opens until reaching operating position)		
Fault	Possible cause	Remedy
Platform does not open with motor	Output J1/3 does not deliver output signal	Use test lamp to check according to circuit diagram
	Motor contactor defective	Check motor contactor
Platform does not open	Pushbutton defective	Use test lamp to check contacts in operating element according to circuit diagram, use ground connection JK at PC board
	No voltage at valve plug S4 or S5, defective cable	Check with test lamp
	Control valve S6 or pressure valve locked	Clean or replace
Warning lights on platform are not flashing when platform is open	Tilt sensor b15 at the platform misadjusted or defective	Adjust or replace
	PC board defective	Replace
	Plugs defective	Replace
	Warning lamps are defective	Replace

 <b>Lift</b> (platform moves up to loading edge)		
Fault	Possible cause	Remedy
Platform does not lift up	Pushbutton defective	Use test lamp to check contacts in operating element according to circuit diagram, use ground connection JK at PC board
	PC board does not deliver output at J 1/3	Check PC board according to circuit diagram at plug J 1/3 with test lamp
	Motor contactor in unit does not switch on or is defective	Check motor contactor with test lamp
	Thermoswitch tripped	Allow motor to cool down
Platform is not lifted up although hydraulic unit is running	Directional valve S 3 stuck or defective	Clean or replace
	Solenoid valves S 1 and S 2 at lift cylinder contaminated or defective	Clean or replace
	Suction filter at pump contaminated	Clean or replace
	Platform overloaded	Reduce load according to load diagram
	Hydraulic pump defective	Replace
	Electric motor defective	Replace
	Pressure splitter contaminated or defective	Clean or replace
	Pressure relief valve misadjusted or defective	Adjust and lock the valve or replace it

 <b>Lower</b> (platform moves down until reaching the ground)		
Fault	Possible cause	Remedy
Platform does not come down	Flow valve R 1 or R 2 at lift cylinder stuck or defective	Clean or replace
	Slide bearing sluggish	Clean and lubricate slide bearing
	Hydraulic oil too thick	Change oil, use oil grade as recommended
	Solenoid valve S 1 or S 2 defective	Clean or replace

 <b>Lower</b> (platform moves down until reaching the ground)		
Fault	Possible cause	Remedy
Platform does not come down when operated with hand cable control	Pushbutton defective	Use test lamp to check contacts in operating element according to circuit diagram, use ground connection JK at PC board
	PC board does not deliver output at J 4/15	Disconnect plug J 4, check terminal 15 with test lamp
	No voltage at valve plug S 1 or S 2, defective cable	Check with test lamp
Platform comes down automatically	Solenoid valves S 1 and S 2 at lift cylinder contaminated or defective	Clean or replace

 <b>Fold out</b>		
Fault	Possible cause	Remedy
Link bridge does not fold out, motor is running	Solenoid valves S 10 and S 11 do not open	Clean or replace
	Solenoid valve S 7 does not open	Clean or replace
	Piston seal in tilt cylinder defective	Replace

 <b>Fold in</b>		
Fault	Possible cause	Remedy
Link bridge does not fold in, motor is running	Solenoid valve S 7 does not open	Clean or replace
	Solenoid valve S 12 does not open	Clean or replace
	Solenoid valve S 13 does not open	Clean or replace
	Piston seal in tilt cylinder defective	Replace

<b>Switch on Warnfix</b> (Warnfix is automatically switched on when the platform is opened, left and right lights are switched in parallel)		
<b>Fault</b>	<b>Possible cause</b>	<b>Remedy</b>
<b>Warning light does not flash</b>	<b>Short-circuit in lamp or cabling</b>	<b>Repair short-circuit</b>
	<b>Lamp defective</b>	<b>Replace</b>

 <b>Close</b> (platform closes)		
<b>Fault</b>	<b>Possible cause</b>	<b>Remedy</b>
<b>Platform does not close at all or only on one side</b>	<b>Emergency control of tilt cylinder activated or both activated.</b>	<b>Screw out knurled screws of solenoid valves</b>
<b>Platform does not close</b>	<b>Pushbutton defective</b>	<b>Check contacts in operating element according to circuit diagram using test lamp</b>
	<b>PC board does not deliver output at J 1/3 or J 43/93</b>	<b>Check PC board according to circuit diagram at plug J 1/3 and 43/93 with test lamp</b>
	<b>Motor contactor or valve S 7 in unit do not switch on</b>	<b>Check with test lamp</b>
	<b>Initiator B 25 defective</b>	<b>Check with test lamp according to circuit diagram, replace if required</b>

## Technical Data

### All Models

#### Recommended Battery Capacity

Load weight [kg]	Recommended battery capacity
up to 1250	12 V = 1 x 143 Ah 24/12 V, 24 V = 2 x 12 V, 2 x 105 Ah
1250 to 1750	12 V = 1 x 180 Ah 24/12 V, 24 V = 2 x 12 V, 2 x 143 Ah
over 1750 to 4000	24/12 V, 24 V = 2 x 12 V, 2 x 180 Ah

**Note:** If you use the vehicle exclusively for short-haul transports in urban traffic frequent loading operations, you should a battery of the next higher capacity level. In addition it is recommended to use a stronger alternator.

### All Models

#### Alternators for Recharging the Battery

Load weight [kg]	Recommended alternator [Watt]
up to 1250	630
1250 to 1750	730
over 1750 to 4000	1000

### All Models

#### Temperature Range for Tail Lift Usage

Standard	"Cold climate" option
-20 °C to +60 °C	-40 °C to +60 °C

## Load Diagrams

The following tables show the maximum allowed weight of the payload ( $Q$ ). The table applicable for your tail lift can also be found on the lateral operating element.

The payload ( $Q$ ) comprises everything placed on the platform, e. g. the transported goods, the operator, and any material handling equipment.

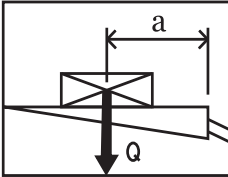

The maximum permissible payload ( $Q$ ) depends on the load distance ( $a$ ). The load distance ( $a$ ) is the distance between the rear edge of the truck load area and the payload center of gravity (**12**).

The maximum permissible payload ( $Q$ ) for the respective maximum permissible load distance ( $a$ ) is permanently indicated on the platform surface with corresponding markings.

### DANGER!



#### Risk of personal injury and material damage!

If the maximum permissible payload ( $Q$ ) or the maximum permissible load distance ( $a$ ) is exceeded, the tail lift could fall down! This can result in personal injuries or the tail lift could be severely damaged. In such a case any warranties shall become void!

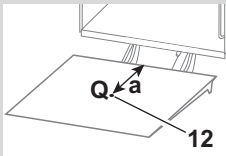

When you position the payload ( $Q$ ) in the center between the left and right platform edge:

- Load the tail lift not heavier than the payload ( $Q$ ), which is indicated in the table next to the respective load distance ( $a$ )!

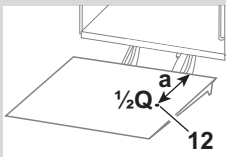

When you position the payload ( $Q$ ) at the left or right platform edge:

- Load the tail lift **not heavier than half the payload** ( $1/2 Q$ ), which is indicated in the table next to the respective load distance ( $a$ )!

A

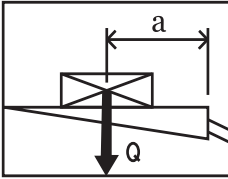

	a [mm]	Q [kg]		a [mm]	Q [kg]
<b>MBB</b>	600	750	<b>MBB</b> <b>C 1750 LD</b> <b>C 1750 SZD</b>	850	1750
<b>C 750 S</b>	700	650		1000	1450
<b>C 750 L</b>	820	550		1300	1150
<b>C 750 LX</b>	1120	400		1650	900
<b>C 750 SX</b>	1800	250		2400	600
<b>C 750 SPL</b>					
<b>MBB</b>	600	1000	<b>MBB</b> <b>C 2000 L</b> <b>C 2000 LZ</b> <b>C 2000 LK</b> <b>C 2000 LX</b>	750	2000
<b>C 1000 L</b>	750	800		900	1650
<b>C 1000 SPL</b>	950	600		1100	1300
<b>C 1000 SPR</b>	1400	400		1600	950
<b>C 1000 ML</b>	2400	230		2400	600
<b>C 1000 ML PRO</b>					
	700	1000	<b>MBB</b> <b>C 2000 S</b> <b>C 2000 SK</b>	1000	2000
<b>MBB</b>	875	800		1200	1650
<b>C 1000 S</b>	1150	600		1500	1350
<b>C 1000 SB</b>	1700	400		1800	1100
	2400	250		2100	950
	720	1250	<b>MBB</b> <b>C 2500 L</b>	750	2500
<b>MBB</b>	900	1000		900	2050
<b>C 1250 LD</b>	1200	750		1100	1700
	1800	500		1600	1150
	2400	370		2400	750
<b>MBB</b>	600	1500	<b>MBB</b> <b>C 2500 S</b> <b>C 2500 SK</b> <b>C 2500 SZ</b>	1000	2500
<b>C 1500 L</b>	720	1250		1400	1785
<b>C 1500 LB</b>	900	1000		1600	1560
<b>C 1500 LX</b>	1200	750		1800	1385
<b>C 1500 ML</b>	2400	370		2400	1040
<b>C 1500 ML PRO</b>					
	1000	1500	<b>MBB</b> <b>C 3000 S</b>	1000	3000
<b>MBB</b>	1200	1250		1200	2000
<b>C 1500 S</b>	1500	1000		1500	1600
<b>C 1500 SZ</b>	1850	800		1800	1300
<b>C 1500 SK</b>	2400	600		2400	1000

**B**

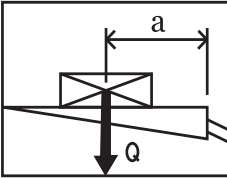

	a [mm]	Q [kg]
<b>MBB C 500 LG</b>	600	500
	700	430
	820	360
	1120	260
	1800	160

**C**

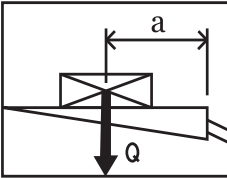

	a [mm]	Q [kg]
<b>MBB C 350 VAN</b>	850	350
	1000	300
	1200	250
	1500	200
	1800	160

	a [mm]	Q [kg]
<b>MBB C 500 VAN</b>	600	500
	700	430
	820	360
	1120	260
	1800	160

**E**

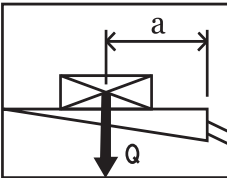

	a [mm]	Q [kg]
<b>MBB C 1000 E</b>	600	1000
	750	800
	950	600
	1400	400
	2400	230

**F**

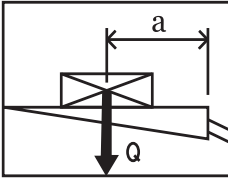

	a [mm]	Q [kg]		a [mm]	Q [kg]
<b>MBB R 750 L</b>	600	750	<b>MBB R 2000 L R 2000 LK R 2000 L TRAIL R 2000 L TRUCK</b>	750	2000
	700	650		900	1650
	820	550		1100	1300
	1120	400		1600	950
	1800	250		2400	600
<b>MBB R 1000 S R 1000 S TRUCK</b>	700	1000	<b>MBB R 2000 S</b>	1000	2000
	875	800		1200	1650
	1150	600		1500	1350
	1700	400		1800	1100
	2400	250		2100	950
<b>MBB R 1500 L R 1500 L FLAT R 1500 LX FLAT</b>	600	1500	<b>MBB R 2500 L R 2000 L TRAIL</b>	750	2500
	720	1250		900	2050
	900	1000		1100	1700
	1200	750		1600	1150
	2400	370		2400	750
<b>MBB R 1500 S R 1500 SK R 1500 S TRAIL R 1500 S TRUCK</b>	1000	1500	<b>MBB R 2500 S</b>	1000	2500
	1200	1250		1400	1785
	1500	1000		1600	1560
	1850	800		1800	1385
	2400	600		2400	1040

**G**

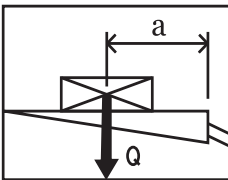

	a [mm]	Q [kg]		a [mm]	Q [kg]
<b>MBB R 750 SM</b>	600	750	<b>MBB R 1500 SM R 1500 SH</b>	1000	1500
	700	650		1200	1250
	820	550		1500	1000
	1120	400		1850	800
	1800	250		2400	600
<b>MBB R 1000 LM</b>	600	1000	<b>MBB R 2000 LM R 2000 LH</b>	750	2000
	750	800		900	1650
	950	600		1100	1300
	1400	400		1600	950
	2400	230		2400	600

**K**

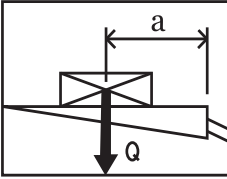

	a [mm]	Q [kg]
<b>MBB F 1000 SH F 1000 SX</b>	600	1000
	750	800
	1000	600
	1500	400
	2400	250
<b>MBB F 1500 LH F 1500 LX</b>	600	1500
	720	1250
	900	1000
	1200	750
	2400	370

	a [mm]	Q [kg]
<b>MBB F 2000 LH</b>	750	2000
	900	1650
	1100	1300
	1600	950
	2400	600

**L**

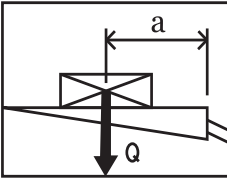

	a [mm]	Q [kg]
<b>MBB F 1000 L</b>	600	750
	700	650
	820	550
	1120	400
	1800	250
<b>MBB F 1000 LD</b>	650	1000
	850	800
	1150	600
	1700	400
	2400	250

	a [mm]	Q [kg]
<b>MBB F 1250 S</b>	550	1250
	650	1000
	900	750
	1350	500
	2400	250
<b>MBB F 1500 L</b>	600	1500
	720	1250
	900	1000
	1200	750
	2400	370

**M**

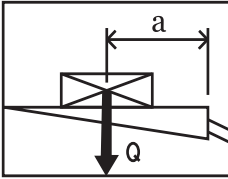

	a [mm]	Q [kg]
<b>MBB F 500 L</b>	600	500
	700	430
	820	360
	1120	260
	1800	160

	a [mm]	Q [kg]
<b>MBB F 600 L</b>	600	600
	700	430
	820	360
	1120	260
	1600	160

**V**

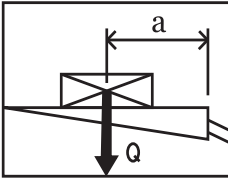

	a [mm]	Q [kg]
<b>MBB V 4000 S</b>	1500	4000
	1750	3400
	2000	3000
	2250	2600
	2500	2400

## Hydraulic Diagrams

### A K Standard Tail Lift with Four Cylinders 96-560.98-00.00-00

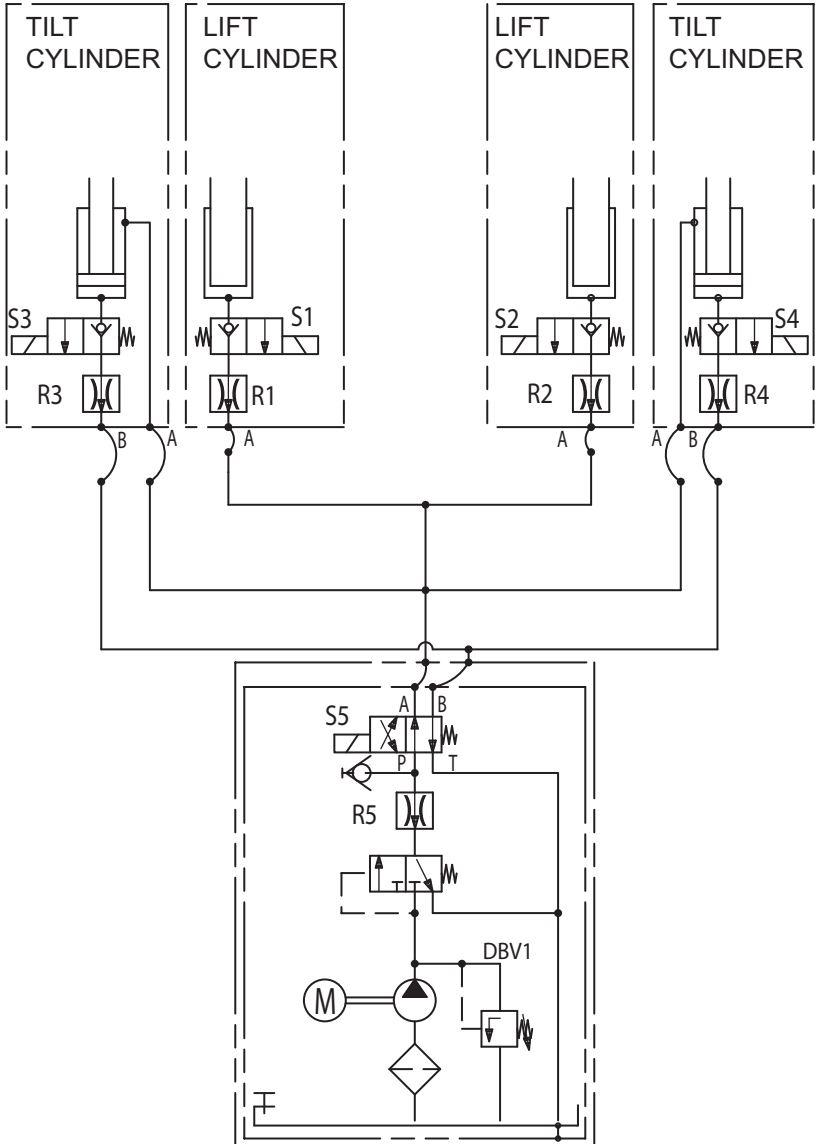

**A C** Standard Tail Lift with Two Cylinders  
97-510.98-00.00-00

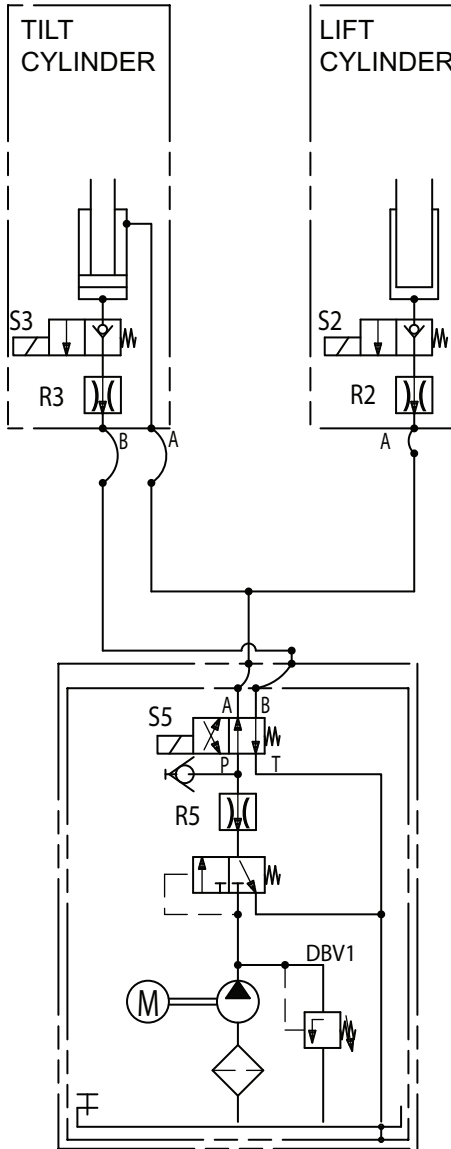

**A** Standard Tail Lift with Hydraulic Support  
96-524.98-01.00-00

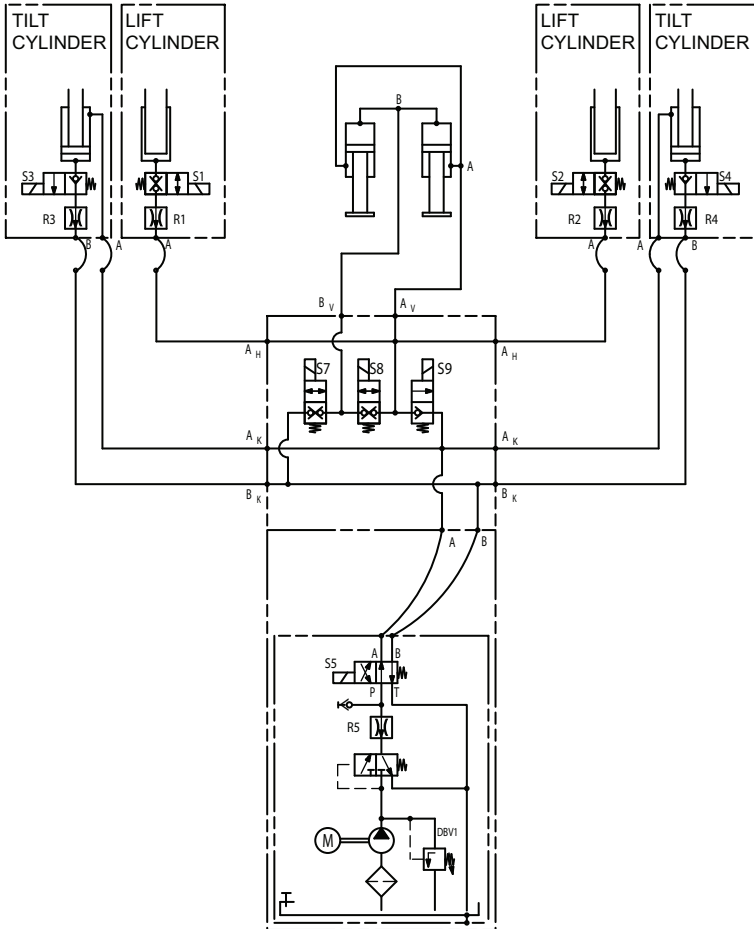

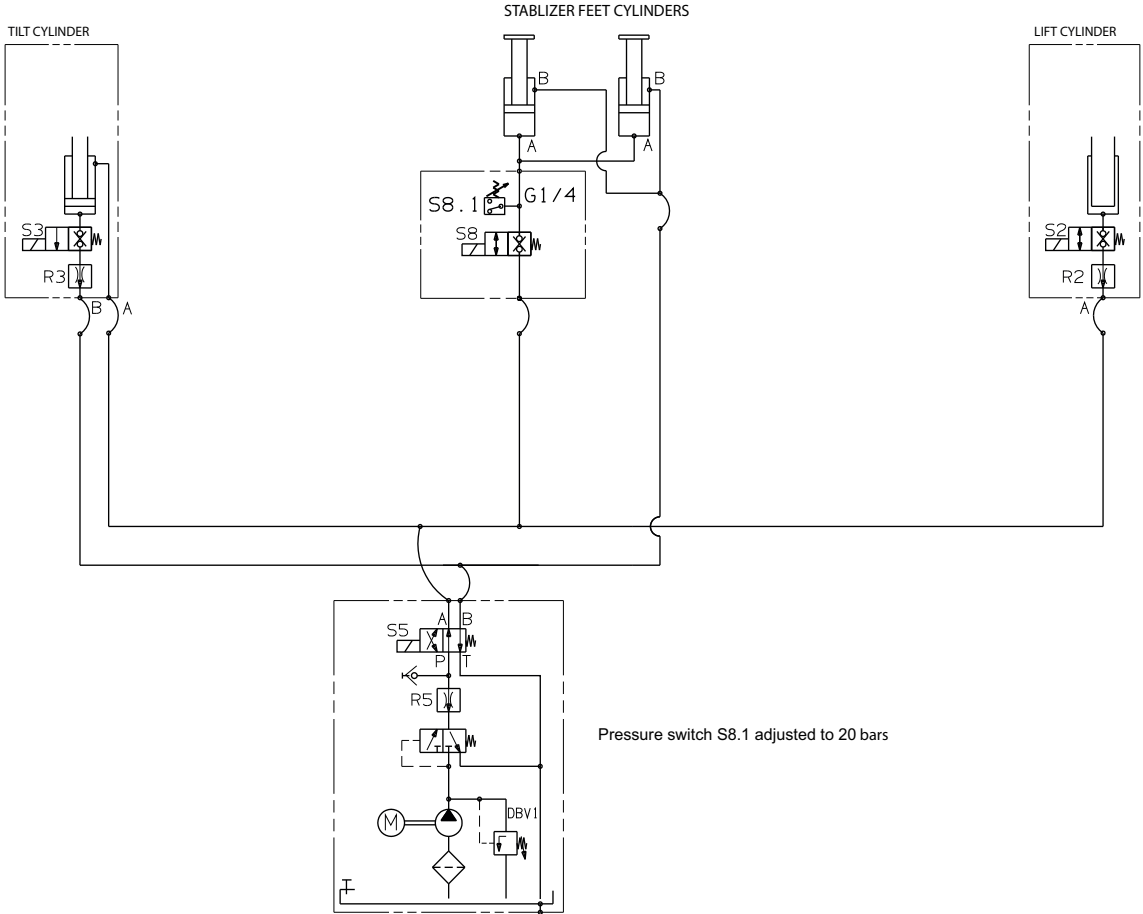

**A** Tail lift with hydraulic stabilizer feet  
MBB C 750 L – C 1000 L

**A** Standard Tail Lift with Hydraulic Underrun Bumper  
99-514.98-01.00-00

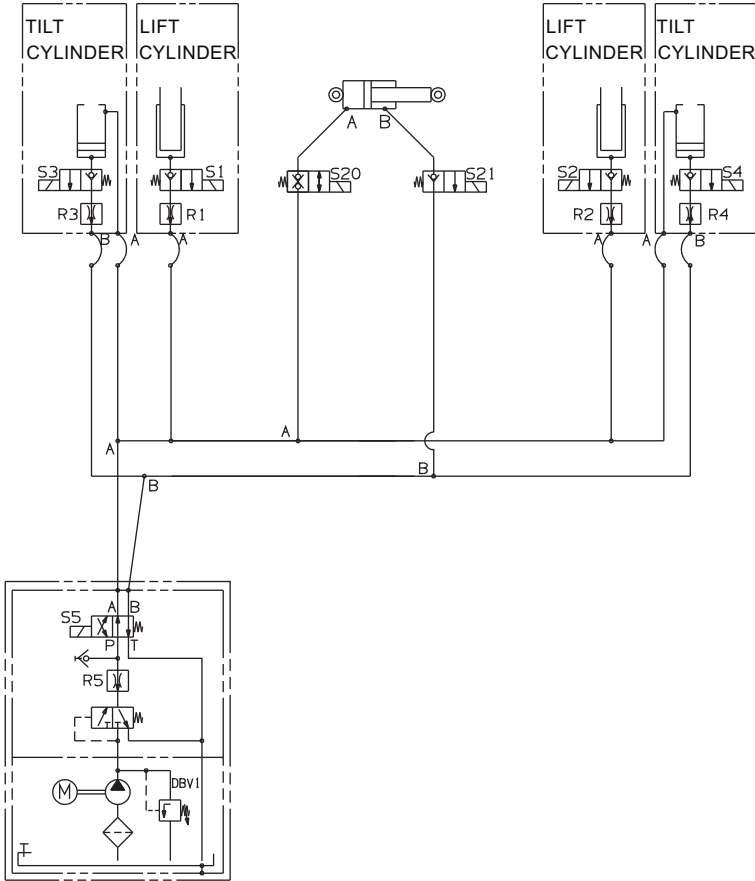

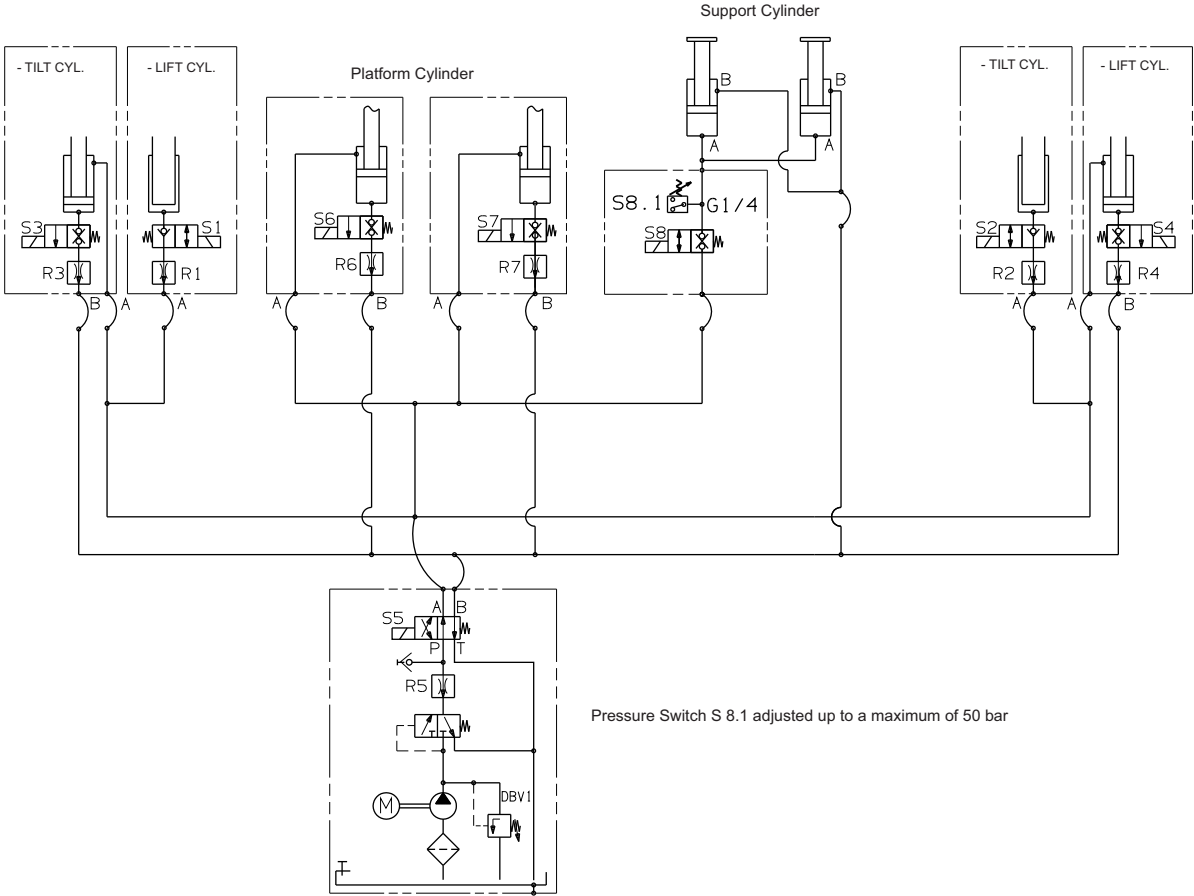

Pressure Switch S 8.1 adjusted up to a maximum of 50 bar

**A** Standard Tail Lift MBB C 750 SX  
13-631.98-02.00-00/3

**A Standard Tail Lift MBB C 1000 SB-C 1500 LB**  
 13-570.98-02.00-00

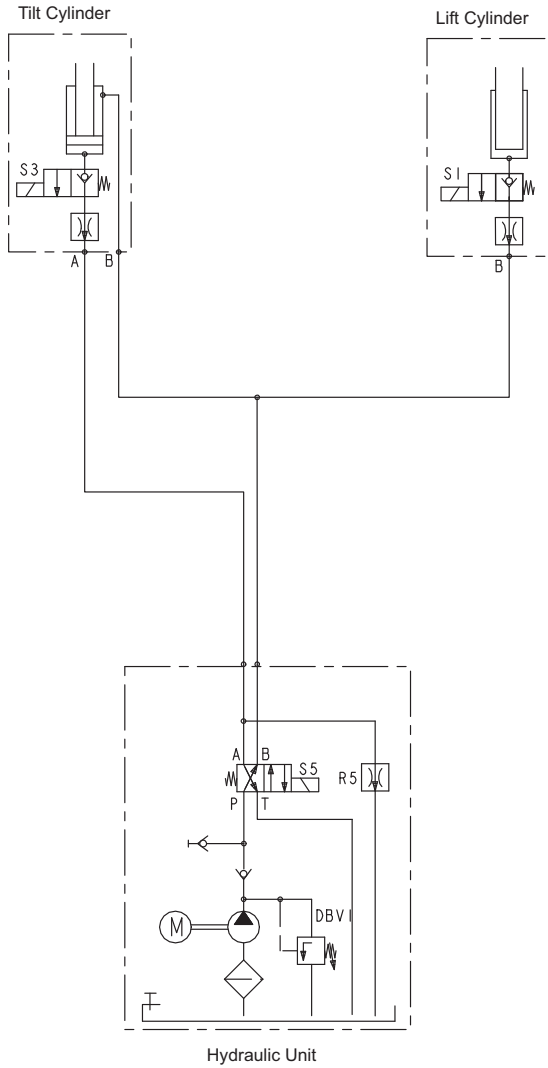

**A** Standard Tail Lift MBB C 1000 SB-C 1500 LB with Pressure Intensifier  
13-570.98-01.00-00

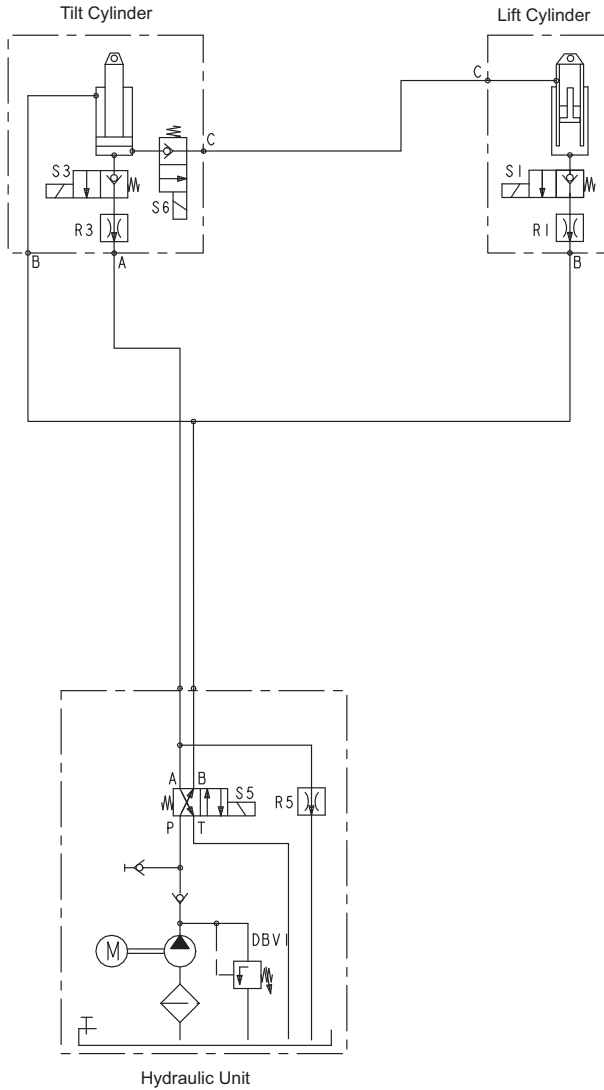

**F G** Retractable Tail Lift  
95-585.98-01.00-00

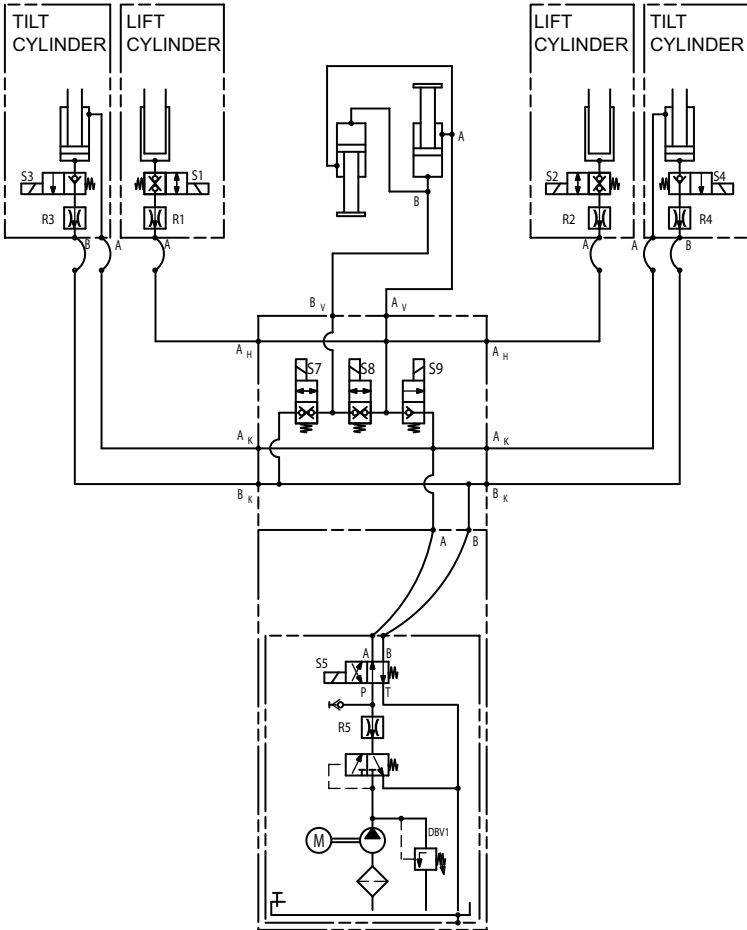



**F** Retractable Tail Lift MBB R 1500 L FLAT  
99-553.98-01.00-00/3

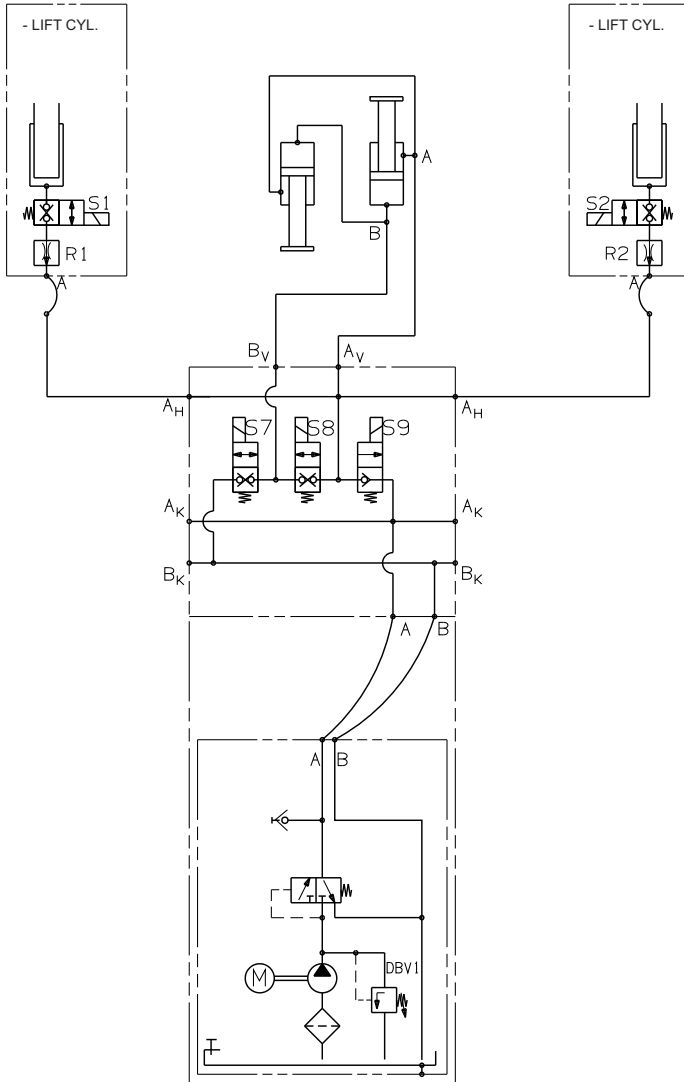

**G** Retractable Tail Lift MBB R 1500 SH and R 2000 LH  
00-514.98-00.00-00

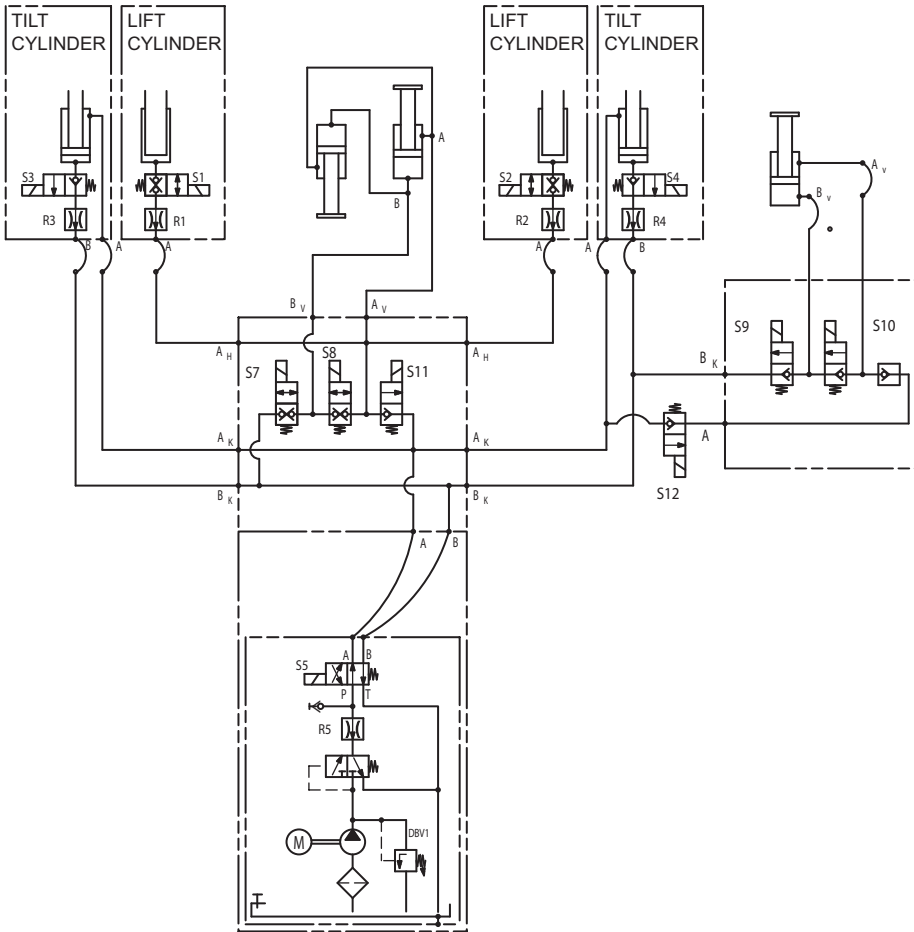

**L** **Foldable Tail Lift**  
93-505.60-08.00-00

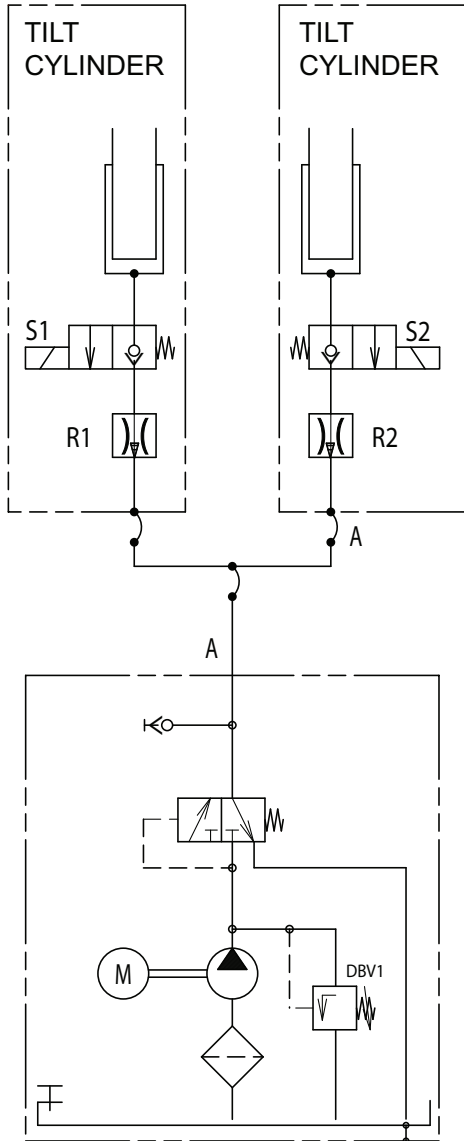

**B M** **Foldable Tail Lift**  
02-528.60-08.00-00

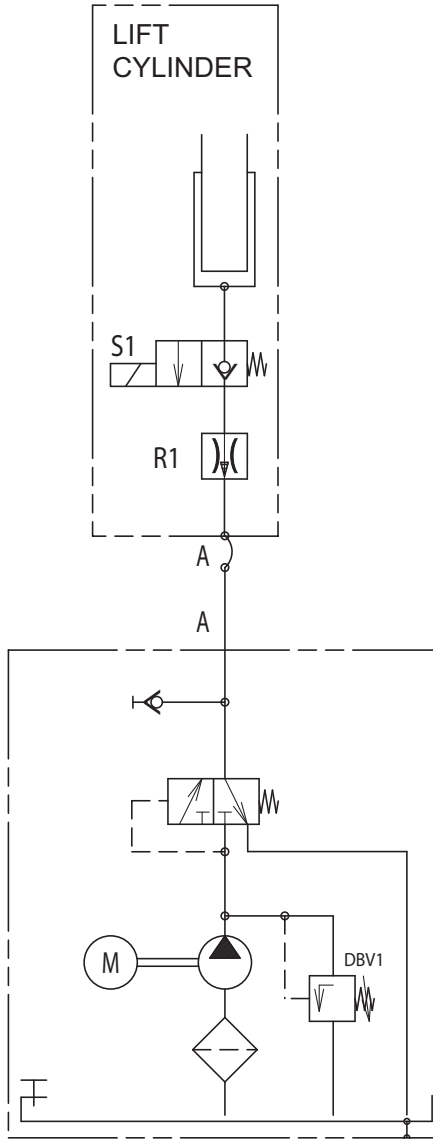



# Lubricants and Operating Media

## Recommended Hydraulic Oil Grades

- Shell Tellus S2 V 15  
operation temperature:  $-20\text{ }^{\circ}\text{C}$  to  $60\text{ }^{\circ}\text{C}$
- Aero Shell Fluid 41  
Operation temperature:  $-54\text{ }^{\circ}\text{C}$  to  $90\text{ }^{\circ}\text{C}$

"Cold climate" option

- Aero Shell Fluid 41 and low temperature gaskets against vitrification of sealing material  
Operation temperature: up to  $-54\text{ }^{\circ}\text{C}$

## Environment-friendly Oils

Increasing awareness for the environment calls for environment-friendly, biodegradable oils for hydraulic equipment. On request we can supply you with an oil grade tested by us. The operation temperature of this oil is listed as  $-20\text{ }^{\circ}\text{C}$  to  $60\text{ }^{\circ}\text{C}$ . Please contact us.

When using other oil types, this may result in damage to cylinder seals or annoying noise.

## Recommended Lubricant Grease

- Shell Gadus S2 (Heavy duty grease)
- Comparable lubricant grease

## Available Accessories

The available accessories are listed in the spare parts catalog of your contractor repair shop. The list of repair shops shows you the nearest repair shop and provides further contact information.

## Certificate for securing a load with tail lifts Requirements specification and load prerequisites

### 1. Information on the tail lifts

Tail lifts manufacturer:	MBB PALFINGER GmbH Fockestraße 53 27777 Ganderkesee
Tail lifts type	Standard - HLB with 2 tipping and 2 lifting cylinders
with platforms:	Aluminum and steel
Control arm length:	up to 1,100 mm

**The tail lifts fulfill the requirements of DIN EN 12642 Code XL.**

### 2. Information on types and equipment for tail lifts

The tail lifts is to secure loads in the location named under point 4 under maintenance of the loading conditions named under point 3, if the following equipment components are present:

	Permissible load masses	Demonstrated max. test forces (DIN EN 12642)
<b>2.1. Tail Lift load capacity 500 kg to 750 kg – all pitches</b>		
Platform dimensions:	Height: 1,200 – 2,000 mm Width: 1,750 – 2,600 mm Bearing bolt diameter Ø25 mm	
Control arm length:	600 to 800 mm	
Nominal load:	500 kg to 750 kg	
<b>Platform heights : up to 2,000 mm</b>	<b>5,000 kg</b>	<b>1,500 daN</b>
<b>2.2. Tail Lift load capacity 500 kg to 1000 kg – support tube ST180 and all pitches</b>		
Platform dimensions:	Height: 1,200 – 2,000 mm Width: 1,750 – 2,600 mm Bearing bolt diameter Ø25 mm	
Control arm length:	600 to 800 mm	
Nominal load:	500 kg to 1,000 kg	
<b>Platform heights : up to 1,600 mm</b>	<b>8,000 kg</b>	<b>2,400 daN</b>
<b>Platform heights : up to 1,800 mm</b>	<b>7,500 kg</b>	<b>2,250 daN</b>
<b>Platform heights : up to 2,000 mm</b>	<b>7,000 kg</b>	<b>2,100 daN</b>
<b>2.3. Tail Lift load capacity 1000 kg to 1500 kg – all pitches</b>		
Platform dimensions:	Height: 1,200 – 2,600 mm Width: 1,750 – 2,600 mm Bearing bolt diameter Ø28 mm	
Control arm length:	700 to 900 mm	
Nominal load:	1,000 kg to 1,500 kg	
<b>Platform heights : up to 2,000 mm</b>	<b>12,000 kg</b>	<b>3,600 daN</b>
<b>Platform heights : up to 2,200 mm</b>	<b>11,000 kg</b>	<b>3,300 daN</b>
<b>Platform heights : up to 2,400 mm</b>	<b>10,000 kg</b>	<b>3,000 daN</b>
<b>Platform heights : up to 2,600 mm</b>	<b>9,000 kg</b>	<b>2,700 daN</b>

**This certificate is comprised of 2 pages and is only valid in its complete form.**



**2.4. Tail Lift load capacity 1500 kg to 2500 kg – all pitches**

Platform dimensions: Height: 1,200 – 2,800 mm  
 Width: 1,750 – 2,600 mm  
 Bearing bolt diameter Ø36 mm  
 Control arm length: 700 to 1,100 mm  
 Nominal load: 1,500 kg to 2,500 kg

**Permissible load masses**      **Demonstrated max. test forces (DIN EN 12642)**

Platform heights : up to 2,000 mm	16,000 kg	4,800 daN
Platform heights : up to 2,200 mm	14,500 kg	4,350 daN
Platform heights : up to 2,400 mm	13,000 kg	3,900 daN
Platform heights : up to 2,600 mm	11,500 kg	3,450 daN
Platform heights : up to 2,800 mm	10,000 kg	3,000 daN

**2.5. Tail Lift load capacity 2000 kg to 3000 kg – all pitches**

Platform dimensions: Height: 1,200 – 3,000 mm  
 Width: 1,750 – 2,600 mm  
 Bearing bolt diameter Ø40 mm  
 Control arm length: 800 to 1,100 mm  
 Nominal load: 2,000 kg to 3,000 kg

Platform heights : up to 2,000 mm	21,000 kg	6,300 daN
Platform heights : up to 2,200 mm	19,000 kg	5,700 daN
Platform heights : up to 2,400 mm	17,000 kg	5,100 daN
Platform heights : up to 2,600 mm	15,000 kg	4,500 daN
Platform heights : up to 2,800 mm	13,000 kg	3,900 daN
Platform heights : up to 3,000 mm	11,000 kg	3,300 daN

**The condition of the tail lifts is to be inspected regularly according to VDI 2700.**

**3. Information on the loading**

The tail lifts are in the position to secure loads in the location named under point 4 under maintenance of the listed equipment named under point 3 under the following loading conditions:

- Sliding-friction value of a least  $\mu_D = 0.30$
- Form-fit loading against driving direction
- Loading with clearance at least tail lifts width less 10 cm

**4. Information on load**

The tail lifts is assured for the following loads under maintenance of the conditions listed under point 2 and 3, according to the parameters of recognized rules of technology, e.g. acceleration values according to DIN EN 12195-1, of the VDI directives 2700 following pages and the certificates and appraisals.

- General cargo
- Palletized loading

TÜV NORD Mobilität GmbH & Co. KG

**MBB PALFINGER GmbH**  
 Ganderkesee

Hannover, 25.03.2015

*Martin Keller*  
 Martin Keller

*H. Herberich*  
 Signature of the responsible party

**This certificate is comprised of 2 pages and is only valid in its complete form.**

# Index

- A**  
accessories 178  
alternators 156  
annual maintenance 133
- B**  
battery capacity 156  
battery check 124  
Battery main switch 26, 37  
bolts check 132  
breather filter 134, 136  
bringing down the platform 32
- C**  
carbon brush check 124  
checks 138  
clamp 136  
cleaning 124  
closing the platform 32  
conical lubricating head 126  
control panel 12
- D**  
Driver's cab control unit 37
- E**  
easy move 58, 62  
Einhandsteuerung  
    hydraulische Stützen 52  
explanation of terms 32  
extending the platform 32, 33
- F**  
faults 139
- troubleshooting tables 141, 148, 152  
folding in the platform 32  
folding out the platform 32  
folding part of platform 14  
foot control 14, 98
- G**  
greasing 125  
ground adjustment of platform 22, 33, 42  
guide cylinder 14  
guide pulley 14  
guide rails 14
- H**  
Hand cable control 100, 102, 105  
hand cable control 14  
holding bar on platform 14  
hydraulic diagrams 163  
hydraulic oil  
    changing 133, 136  
    environment-friendly oils 178  
    recommendations 178  
hydraulic oil reservoir 134, 136  
hydraulic stabilizer feet 27  
hydraulic system check 132  
hydraulic unit 14
- K**  
key code 26, 37  
    programming 116  
key control 26, 36
- L**  
lateral operating element 38  
lateral operating panel 14

lift arms switch 14  
 lift cylinder 14  
 lifting the platform 32  
 low-maintenance bearings 133  
 lubricants 178  
 lubricating 125

## M

main switch 138  
 maintenance 120  
     annual 133  
     before starting 123  
     depending on usage frequency 124  
     monthly 130  
 mechanical stabilizer feet 27  
 model overview 12, 14  
 monthly maintenance 130

## N

nuts check 132

## O

oil 125, 130  
 oil drain plug 134, 136  
 oil level check 130  
 one-hand control 38  
     easy move 62  
     hydraulic stabilizer feet 50  
 opening the platform 32  
 operating element  
     foot control 98  
     Hand cable control 100, 102, 105  
     lateral 38  
     special operating elements 110, 112, 114  
     two hand cable controls 92  
     wireless remote control unit (standard) 108  
 operating media 178

operator position. 125  
 overview  
     column lifts 21  
     foldable tail lifts 13, 20  
     retractable tail lifts 13, 18  
     retraction equipment 19  
     standard tail lift 14, 17  
     standard tail lifts 12

## P

payload 157  
 payload center of gravity 14, 125  
 platform 14  
     close 32, 34, 38  
     extend 32, 38  
     fold in 32, 34, 38  
     fold out 32, 33, 38  
     ground adjustment 32  
     lift 32, 34  
     load 34  
     lower 32, 33, 38  
     moving 31  
     open 32, 33, 38  
     platform tilt 32  
     position horizontally 32, 38  
     retract 32, 34, 38  
     unload 34  
 platform package 14  
 platform tilt 22, 33  
 presetting the tail lift 22  
 pushbutton 38

## Q

qualification of personnel 7

## R

refresh marks 125  
 retracting the platform 32  
 roll stop 14  
 roll-off protection bearings 126

rotary switch 38

## S

safety devices 123  
     checking 123  
 safety instructions 8  
 scope of delivery 11  
 service 120  
 Service counter 117  
 setting the platform tilt 33  
 setting the platform to its horizontal position 33  
 sliding console in the guide rails 127  
 spare parts 178  
 special operating elements 110, 112, 114  
 stabilizer feet  
     hydraulic 27, 44  
     mechanical 27  
 standard wireless remote control unit 108  
 stationary part of platform 14  
 suction filter 134, 136  
 support tube 14  
 supporting strap on body 14  
 Switch in driver's cab 25, 36

## T

Tail lift 32  
     close 32, 34  
     extend 32, 33  
     fold in 32, 34  
     fold out 32, 33  
     ground adjustment 32  
     lift 32, 34  
     load 34  
     lower 32, 33  
     moving 31  
     open 32, 33  
     platform tilt 32  
     position horizontally 32  
     presetting 22

retract 32, 34  
 switch off 36  
 switching on 25  
 unload 34

## tail lift

close 38  
 extend 38  
 fold in 38  
 fold out 38  
 lower 38  
 open 38  
 position horizontally 38  
 retract 38

tail lift models 12, 14  
 technical data 156  
 temperature range 156  
 tilt cylinder 14  
 tilt sensor 14  
 toggle switch 38  
 torsion frame 14  
 troubleshooting 117  
 two hand cable controls 92  
 two-hand control 38  
     easy move 58  
     hydraulic stabilizer feet 44, 46  
     pushbuttons 54

## U

underrun bumper 14

## V

valve block 134, 136

## W

warning devices 123  
 warning lights 14  
 wireless remote control unit 108

**PALFINGER Tail Lifts GmbH**

Fockestraße 53  
D-27777 Ganderkesee/Hoykenkamp  
Tel.: +49-4221 8530  
Fax: +49-4221 87536  
infombb@palfinger.com  
www.palfinger.com

**PALFINGER Hayons S.A.S**

Rue de l'Eglise  
F-61310 Silly en Gouffern  
Tel.: +33-2 33 12 44 00  
Fax: +33-2 33 12 44 01  
francembb@palfinger.com  
www.palfinger.com

**PALFINGER Tail Lifts s.r.o.**

Gogolova 18  
SK-85101 Bratislava  
Tel.: +421-252 636 611  
Fax: +421-252 636 612  
mbbsk@palfinger.com  
www.palfinger.com

**PALFINGER Tail Lifts Ltd.**

Bessemer Road  
Welwyn Garden City  
UK-Herts AL7 1ET  
Tel.: +44-01707 325571  
Fax: +44-01707 327752  
inforatcliff@palfinger.com  
www.palfinger.com