

RENAULT

PK32080

K380

CONTRACT NUMBER: 2000100720

NEW

ON REQUEST



SPECIFICATION

TRUCK K 380 P6X4 HEAVY.34 E3

- Wheelbase: 4600mm
- Engine-type: DXi11
- Performance: 240 kW Euro3
- Suspension front: 3-leaf reinforced front leaf springs & stabiliser bar
- Suspension rear: 11-leaf elliptic suspension, stabiliser bar & rear shock absorbers
- Maximum weight front axle: 9.000 kg
Maximum weight rear axle: 32.000 kg
- Payload: 18 Tn
- Tire dimension: 13 R22.5.
- Profile B. M840 EVO / L355 EVO.
- Steel disc wheels Configured to local market

LOADER CRANE: PK32080

- Adapted to local market NON-CE
- Lifting moment: 23,0 mt/226,0 kN
- Outreach / Lifting power: 9,9 m/2900kg

OFFER INFORMATION

Location details

Köstendorf, 5203 - Austria 

Dealer Name

PALFINGER EMEA GmbH



Availability

On request

Product type

new

Contract number

2000100720

Dealer E-mail

sales@palfinger.com

Dealer phone

004366488345792

-
- Extension B (9,9 meters)optimal outreach
 - Additional stabilizers BS001
 - Coating technology KTL
 - High-speed extension
 - Low-maintenance extension system
 - Hydraulic Overload Protection System

*in Option: Radio Remote Control.

TRUCK

Axes	6x4	Payload category	15t-26t
		Construction	Heavy duty crane

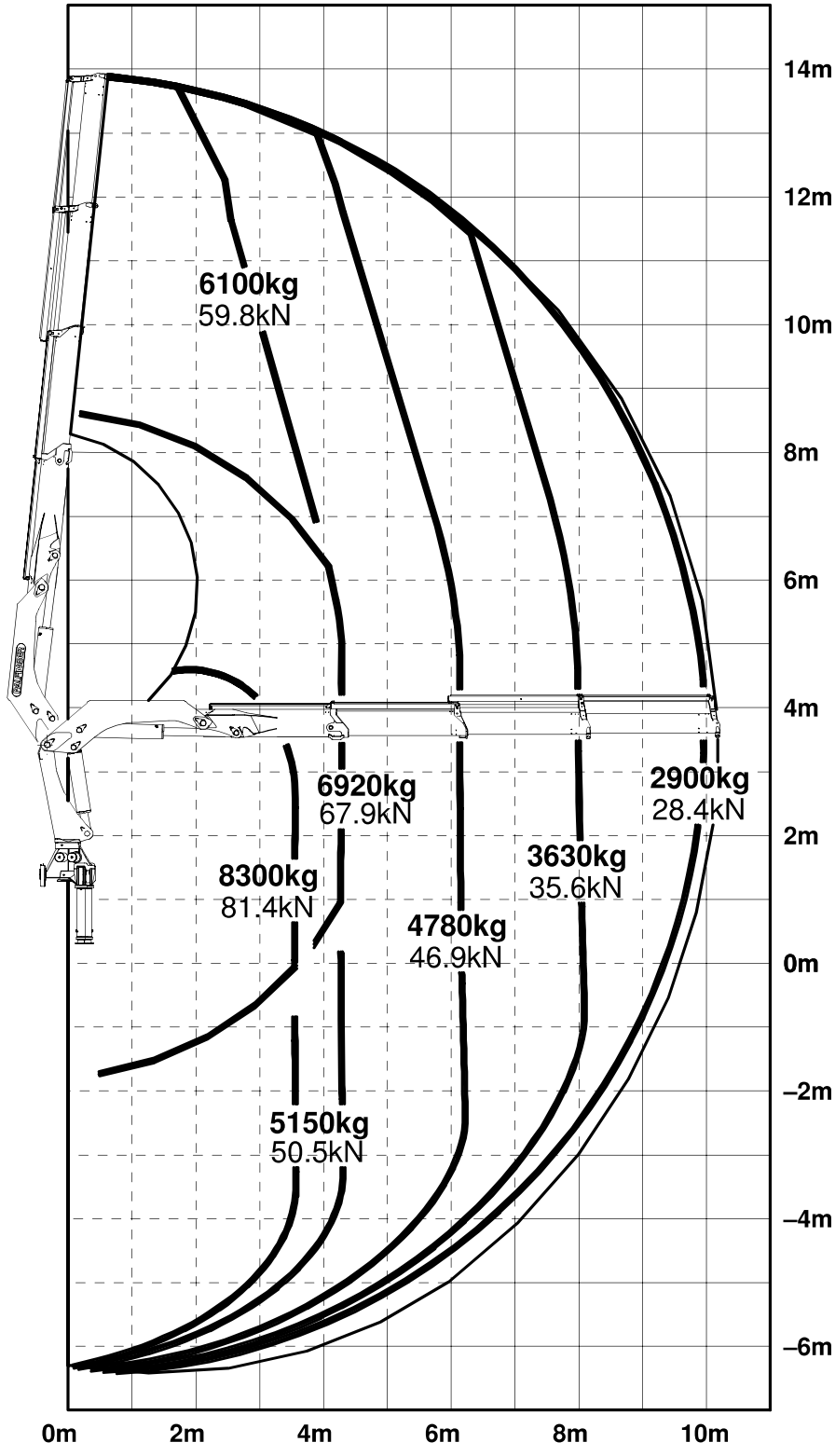

Konstruktionsänderungen vorbehalten, fertigungstechn. Toleranzen müssen berücksichtigt werden.
 Subject to change, production tolerances have to be taken into account.
 Sous réserve de modifications de conception. Les tolérances relatives à la technique de production doivent être prises en considération.

Einstufung: H1/B3 nach DIN15018
 Classification: H1/B3 in DIN15018
 Classement: H1/B3 en mesure DIN15018

PK 32080

**ROBUST AND RELIABLE
TECHNOLOGY WITH A
MAXIMUM MANEUVER-
ABILITY**

LIFETIME EXCELLENCE



LIFETIME EXCELLENCE

PALFINGER loader cranes are convincing due to their superior life-cycle performance. They are the most economical and also the most reliable over the entire product life. From solution finding to resale.

- **Better solutions**
- **Better efficiency**
- **Better ergonomics**
- **Higher availability**
- **More reliability**
- **Better ecology**
- **Higher serviceability**
- **Higher value retention**



PK 32080

HIGH PERFORMANCE

A

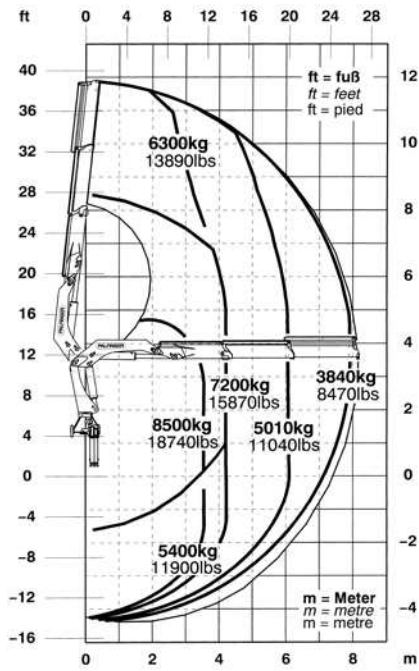

B

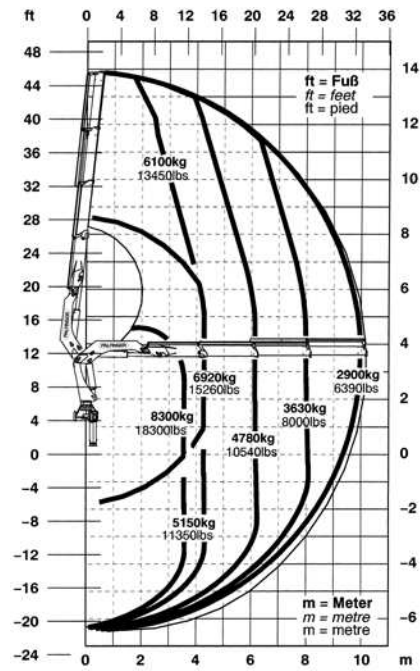

D

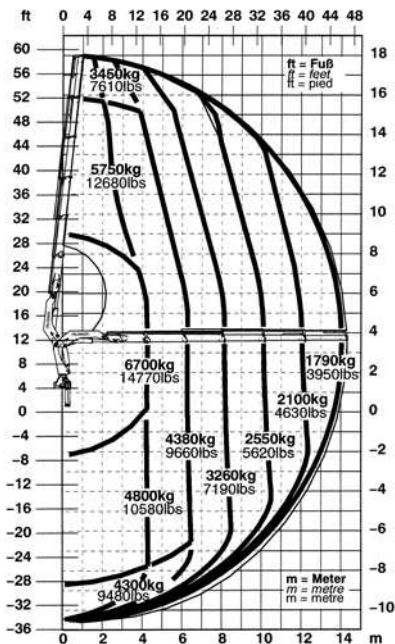

The outreaches stated are with a boom angle of 20° and are therefore not the maximum.

Lifting capacities

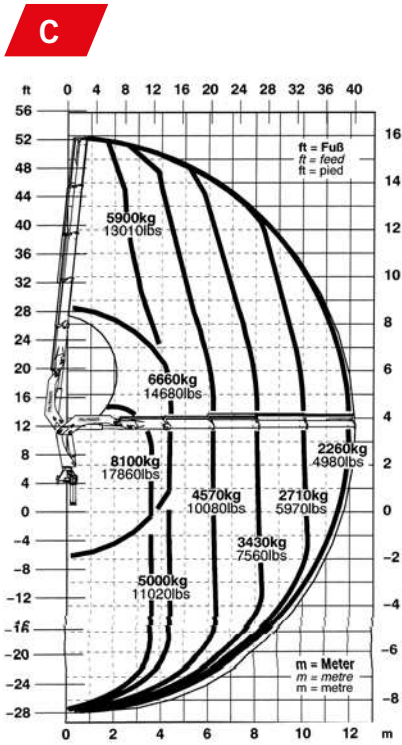

3.5 m	11' 6"	8500 kg	18740 lbs	A
4.2 m	13' 9"	7200 kg	15870 lbs	
6.0 m	19' 8"	5010 kg	11040 lbs	
7.9 m	25' 11"	3840 kg	8470 lbs	

3.6 m	11' 10"	8300 kg	18300 lbs	B
4.3 m	14' 1"	6920 kg	15260 lbs	
6.1 m	20' 0"	4780 kg	10540 lbs	
8.0 m	26' 3"	3630 kg	8000 lbs	
9.9 m	32' 6"	2900 kg	6390 lbs	
11.9 m*	39' 1"	2340 kg	5160 lbs	
14.0 m*	45' 11"	1920 kg	4230 lbs	
16.2 m*	53' 2"	1300 kg	2870 lbs	
18.4 m*	60' 4"	900 kg	1980 lbs	
20.8 m*	68' 3"	600 kg	1320 lbs	

3.6 m	11' 10"	8100 kg	17860 lbs	C
4.4 m	14' 5"	6600 kg	14550 lbs	
6.2 m	20' 4"	4570 kg	10070 lbs	
8.0 m	26' 3"	3430 kg	7560 lbs	
10.0 m	32' 10"	2710 kg	5970 lbs	
11.9 m	39' 1"	2260 kg	4980 lbs	
14.0 m*	45' 11"	1760 kg	3880 lbs	
16.2 m*	53' 2"	1300 kg	2870 lbs	
18.4 m*	60' 4"	900 kg	1980 lbs	
20.8 m*	68' 3"	600 kg	1320 lbs	

4.3 m	14' 1"	6700 kg	14770 lbs	D
4.4 m	14' 5"	6420 kg	14150 lbs	
6.3 m	20' 8"	4380 kg	9660 lbs	
8.1 m	26' 7"	3260 kg	7190 lbs	
10.1 m	33' 2"	2250 kg	5620 lbs	
12.0 m	39' 4"	2100 kg	4630 lbs	
14.0 m	45' 11"	1790 kg	3950 lbs	
16.1 m*	52' 10"	1300 kg	2870 lbs	
18.4 m*	60' 4"	900 kg	1980 lbs	
20.7 m*	67' 11"	600 kg	1320 lbs	

PERFECT DIMENSIONS

EXTENSION BOOM VARIATIONS

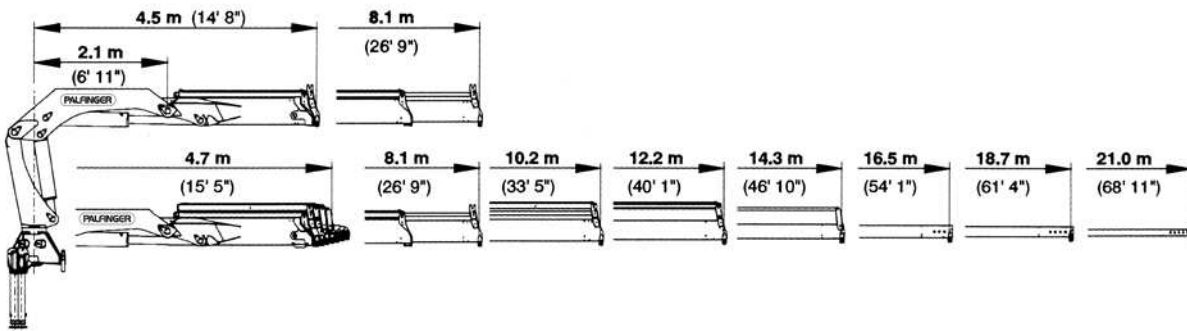

DIMENSIONS

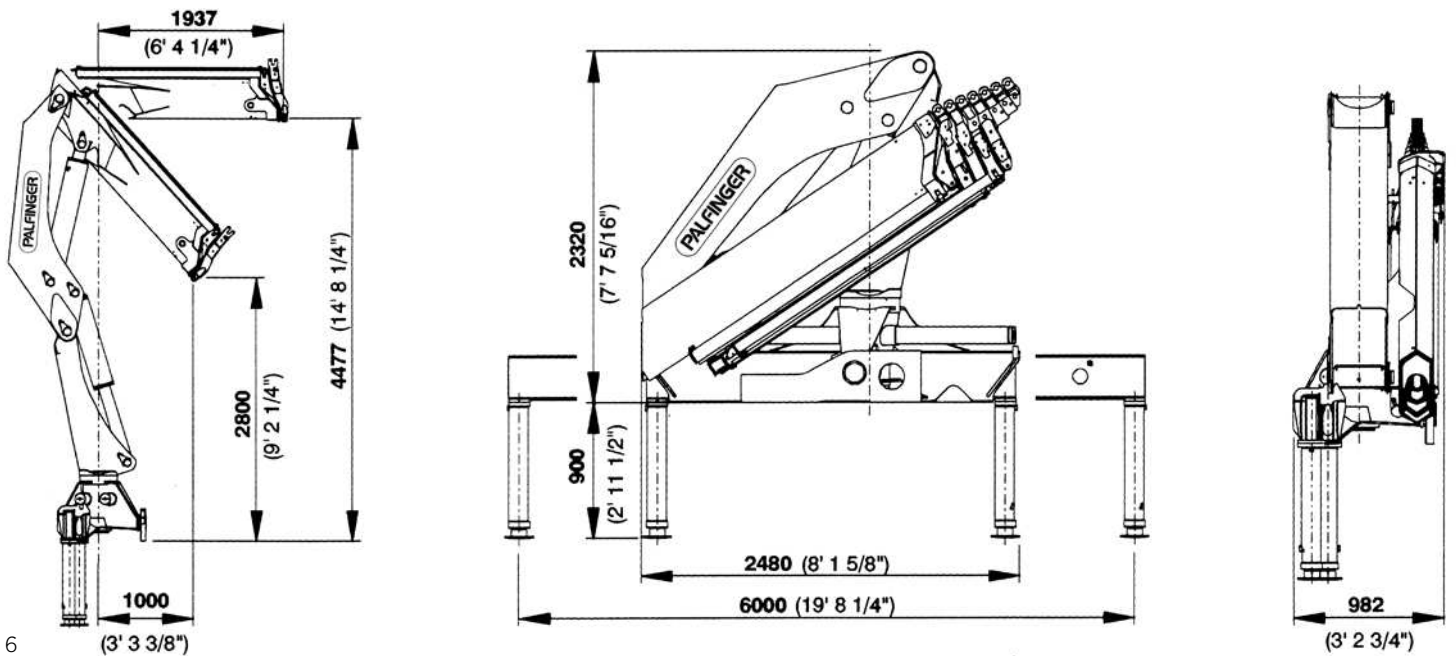

Technical specifications

EN 12999 H1-B3

PK 32080

Max. lifting moment	30.4 mt/298.2 kNm	219860 ft.lbs
Max. lifting capacity	8500 kg/83,4 kN	18740 lbs
Max. hydraulic outreach	14.3 m	46' 11"
Max. manual outreach	21.0 m	68' 11"
Maximum outreach (with Fly-jib)	24.9 m	81' 8"
Slewing angle	400°	
Slewing torque	3.8 mt/37.3 kNm	27500 ft.lbs
Outreach	8.1 m	26' 7"
Stabiliser spread (std./max.)	6.0 m/6.0 m	19' 8"/19' 8"
Fitting space required	0.97 m	3' 2"
Width folded	2.5 m	8' 2"
Operating pressure	300 bar	4350 psi
Recommended pump capacity	50 l/min	13.2 US gal./min
Dead weight (std.)	3130 kg	6900 lbs

KP-PK32080M2+EN

Cranes shown in the leaflet are partially optional equipped and do not always correspond to the standard version. Country-specific regulations must be observed. Dimensions may vary. Subject to technical changes, errors and translation mistakes.

PK 32080

**TECHNIQUE ROBUSTE
ET FIABLE AVEC UN
MAXIMUM DE MOBILITÉ**

LIFETIME EXCELLENCE



LIFETIME EXCELLENCE

Les grues de manutention PALFINGER se distinguent de par leur cycle de vie plus long. Elles sont les plus rentables et les plus fiables sur la durée de vie totale du produit, de la recherche de solutions jusqu'à la revente.

- **Des solutions mieux adaptées**
- **Une plus grande efficacité**
- **Une meilleure ergonomie**
- **Un entretien simplifié**
- **Une plus grande fiabilité**
- **Un meilleur respect de l'environnement**
- **Une plus grande maniabilité**
- **Une meilleure valeur de revente**



PK 32080

HIGH PERFORMANCE

A

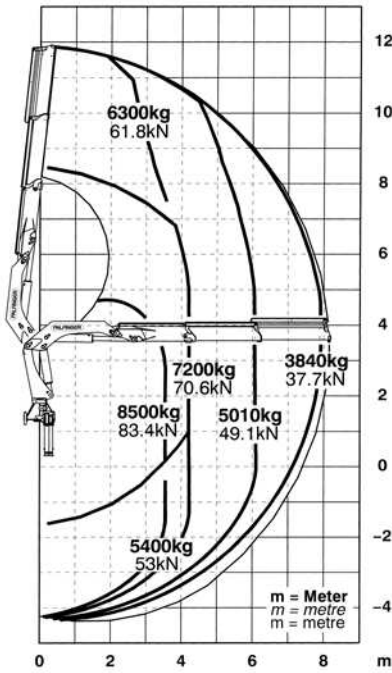

B

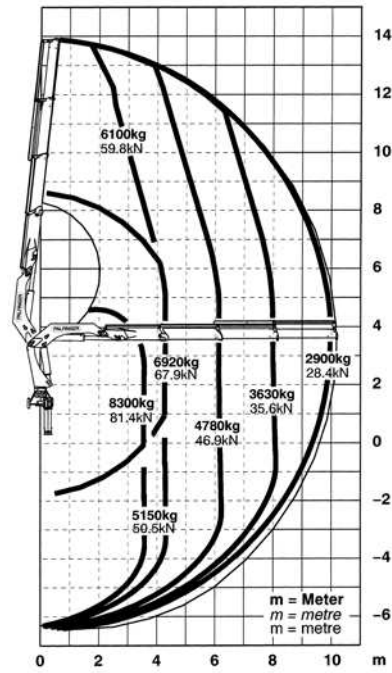

D

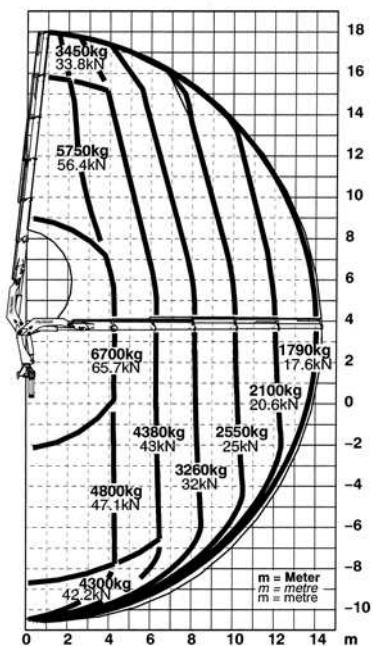

Les portées indiquées sont basées sur le bras principal formant un angle de 20° par rapport à l'horizontale et ne sont pas des maximums.

Forces de levage

C

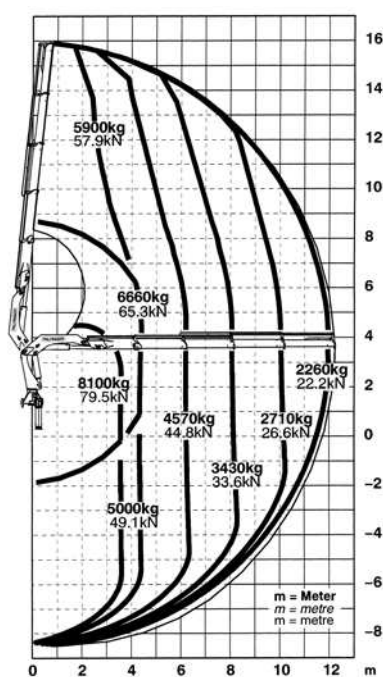

3,5 m	8500 kg / 83,4 kN	A
4,2 m	7200 kg / 70,6 kN	
6,0 m	5010 kg / 49,1 kN	
7,9 m	3840 kg / 37,7 kN	

3,6 m	8300 kg / 81,4 kN	B
4,3 m	6920 kg / 67,9 kN	
6,1 m	4780 kg / 46,9 kN	
8,0 m	3630 kg / 35,6 kN	
9,9 m	2900 kg / 28,4 kN	
11,9 m*	2340 kg / 23,0 kN	
14,0 m*	1920 kg / 18,8 kN	
16,2 m*	1300 kg / 12,8 kN	
18,4 m*	900 kg / 8,8 kN	
20,8 m*	600 kg / 5,9 kN	

3,6 m	8100 kg / 79,5 kN	C
4,4 m	6600 kg / 64,7 kN	
6,2 m	4570 kg / 44,8 kN	
8,0 m	3430 kg / 33,6 kN	
10,0 m	2710 kg / 26,6 kN	
11,9 m	2260 kg / 22,2 kN	
14,0 m*	1760 kg / 17,3 kN	
16,2 m*	1300 kg / 12,8 kN	
18,4 m*	900 kg / 8,8 kN	
20,8 m*	600 kg / 5,9 kN	

4,3 m	6700 kg / 65,7 kN	D
4,4 m	6420 kg / 63,0 kN	
6,3 m	4380 kg / 43,0 kN	
8,1 m	3260 kg / 32,0 kN	
10,1 m	2250 kg / 25,0 kN	
12,0 m	2100 kg / 20,6 kN	
14,0 m	1790 kg / 17,6 kN	
16,1 m*	1300 kg / 12,8 kN	
18,4 m*	900 kg / 8,8 kN	
20,7 m*	600 kg / 5,9 kN	

DIMENSIONS PARFAITES

NOMBREUSES EXTENSIONS

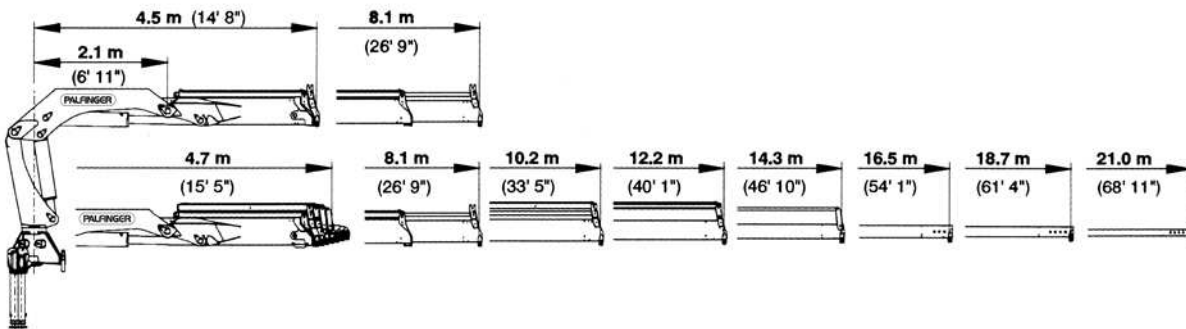

DIMENSIONS

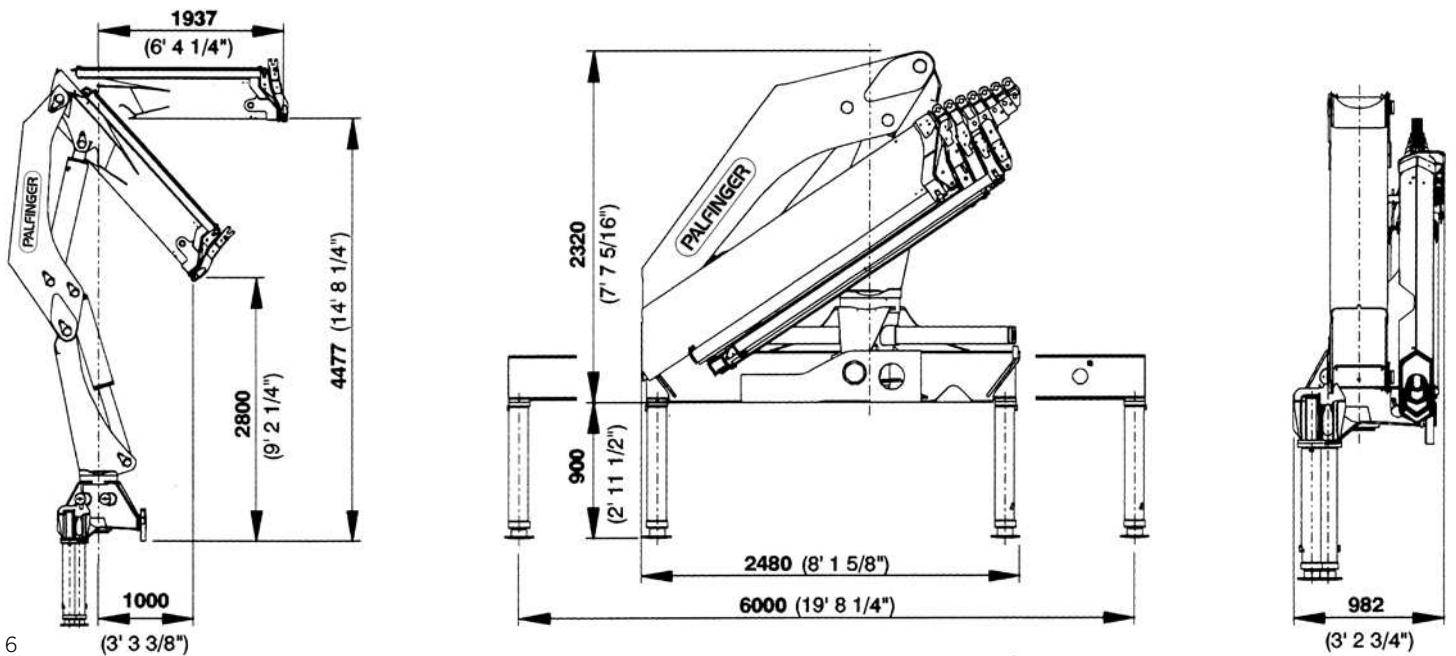

Caractéristiques techniques

EN 12999 H1-B3

PK 32080

Couple de levage	30,4 mt/298,2 kNm
Capacité de levage maximale	8500 kg/83,4 kN
Portée hydraulique maximale	14,3 m
Portée mécanique maximale	21,0 m
Portée maximale (avec fly-jib)	24,9 m
Angle de rotation	400°
Couple de rotation	3,8 mt/37,3 kNm
Portée	8,1 m
Ecartement des stabilisateurs (std./max.)	6,0 m/6,0 m
Espace nécessaire au montage	0,97 m
Largeur grue repliée	2,5 m
Pression d'utilisation	300 bar
Débit de pompe recommandé	50 l/min
Poids de la grue (std.)	3130 kg

KP-PK32080M2+FR

Certaines grues en photos dans ce document sont dotées d'équipements optionnels et ne correspondent pas au modèle standard. Des réglementations nationales spécifiques relatives à la configuration des grues sont à observer. Les dimensions ne revêtent pas un caractère contraignant. Sous réserve de modifications techniques, d'omissions et d'erreurs de traduction.



**THANK YOU FOR YOUR INTEREST IN
THE RENAULT K 380 P6X4 HEAVY.34 E3**

Prepared for :

PALFINGER**TRUCK FOR PALDRIVE PROJECT****Quote**

Configuration date: 06/07/2020

Tariff no.

A1 RTG 37.1

Type of Vehicle	No. of Vehicles	Comment
K 380 P6X4 HEAVY.34 E3	1	QUOTATION N°20660713 UPDATE JULY

VEHICLE DEFINITION

Vehicle	K 380 P6X4 HEAVY.34 E3
Wheelbase	EMPT.4.600
Real Axle ratio	DRIVE AXLE RATIO 3.76
GVW	GVW 34T
GCW	GTW 37.5 T
Colour	EKLA WHITE (09350)
Tyres	B. M748 EVO / L355 EVO 385/65 + 13 R22.5

QUOTATION OF CHASSIS & RENAULT TRUCKS OPTIONS

Description
Basic price
2 REVOLVING LIGHTS (ORANGE)
2 WIDE ANGLE MIRRORS
2-WAY ADJUSTABLE STRG COLUMN
385/65 + 13 R22.5
ADD ELEC INTERFACE BODY/CHASSIS
AUTOMATIC ENGINE CUT-OFF (5 MIN)
B. M748 EVO / L355 EVO
BODYBUILDER CABLE ACCESS TO CAB
CAB ACCESS STEPS MOUNTING REINFORCEMENT.
CAST IRON ENGINE FLYWHEEL CASING
COMPLETE CHASSIS FRONT -> REAR REINFORCEMENT
CONSTRUCTION STD. AIR FILTRATION
EBS + ASR + HSA
ELECTRONIC AIR CONDITIONING
ENGINE HOUR METER
FMS GATEWAY 3.0
FOLDABLE FRT. VIEW MIRROR
FRONT BODY BRACKETS + RR PLATES
HEAVY DUTY GEARBOX COOLING
JACK 20T
KERB VIEW MIRROR
MANUAL ROOF VENT
N = 2945 mm



PROVISION FOR CRANE ELECTRICS
 REGULATORY SPEED LIMITER 80 KM/H
 REM.CONTR.HTD. REAR MIRRORS
 REVERSE BUZZER
 SEAT BELT WARNING
 SIDE MARKER LAMPS
 SPARE WHEEL (PROVISIONAL FIX.)
 STEEL RH VERT. EXH.+SILENCER
 CUSTOMER ADAPTATION FREE SPACE IN THE
 CHASSIS

Total 77 800,00 €

Miscellaneous charges

Description	Comment	Customer Sales price:
Transport from Bourg en Bresse to Spain	(yardhandling included)	797,00 €

Total 797,00 €

QUOTATION SUMMARY

Comments QUOTATION N°20660713 update July

	Per vehicle	No. of Vehicles	Total
Chassis Cab + RENAULT TRUCKS options:	77 800,00 €	1	77 800,00 €
Commercial Discount	- 1 500,00 €	1	-1 500,00 €
Transport	797,00 €	1	797,00 €
Financial interests 30 days	144,55 €	1	144,55 €
Discount	-144,55 €	1	-144,55 €
Net Selling Price FCA Palfinger Spain	77 097,00 €	1	77 097,00 €

- PRODUCTION LEADTIMES : 10 weeks when order is placed and confirmed by Renault Trucks factory (=factory order number) + 4 weeks (in average) for specific customer adaptation free space in the chassis
- 4 weeks summer closure
- PAYMENT TERMS : by bank transfer at 90 days date of commercial invoice -> 60 days free, 30 days with interest at Renault Trucks charge
- INCOTERMS 2020

This proposal is supplied on a purely illustrative and non-contractual basis. Only a signed purchase order subject to our General Conditions of Sale constitutes a valid contract between the parties. **Validity : 6th January, 2021**

Renault Trucks shall not be liable for any delay or failure in performing its obligations or undertakings under this offer, or for any loss, damage, claims or demands of any nature (whether for alleged delays or otherwise), to the extent that such delay or failure is caused, directly or indirectly, by any event, condition, effect or other cause, whether foreseeable or not, arising from or relating to the Coronavirus (Covid-19) outbreak.



A1 - RTG,37.1
 Model code : 31KN130HD001
 Print date: 06/07/2020
 Last updated: 06/07/2020
 Grid Number: 5634679 from 06/07/2020

Prepared for :

PALFINGER

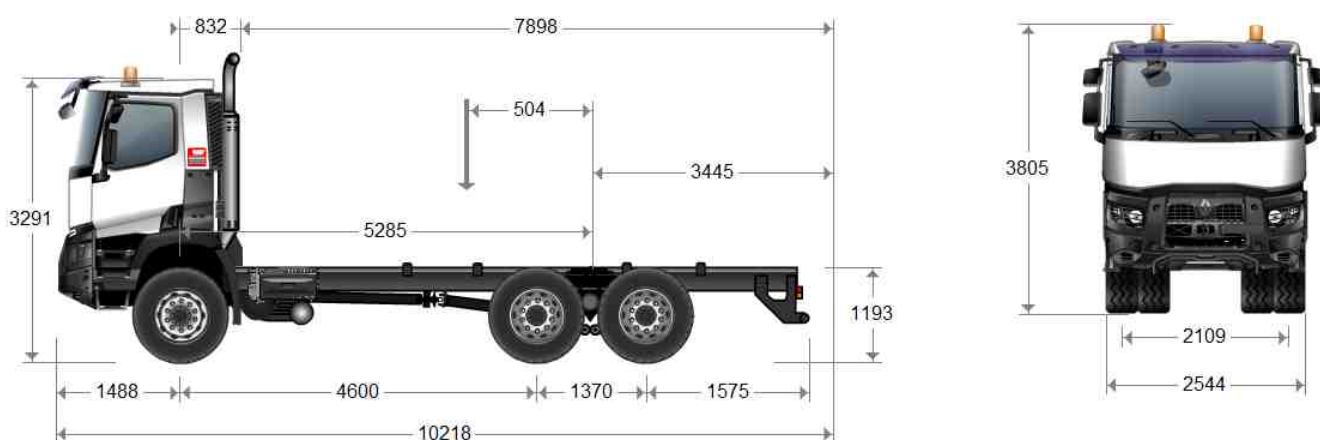
K 380 P6X4 HEAVY.34 E3 - GVW 34T / GTW 37.5 T**RENAULT TRUCKS****K 380****WEIGHTS**

Wheelbase		mm	4.600
Maximum Weight (registered)	Total (GVW)	Kg	34000
Payload	(C)	Kg	24268
Kerb Weight	total	Kg	9732
Chassis cab kerb weight	Front axles (Liftable axle down)	Kg	5256
	Rear axles (Liftable axle down)	Kg	4476
Maximum Weight (registered)	Front axle 1	Kg	8000
	rear axle 1	Kg	13400
	rear axle 2	Kg	13400
	Rear axle(s)	Kg	26800
Maximum Weight (technical)	total (CoC: 16.1.)	Kg	
	front axles (CoC: 16.3.)	Kg	8000
	rear axles (CoC: 16.3.)	Kg	26800

This table includes the weights of the RENAULT TRUCKS options: full urea tank, oil, screen wash fluid and coolant at 100%, fuel fill level 90% and driver present (75 kg)

To maintain the driving comfort (lightness of steering, braking) of vehicles in all load and driving conditions once the vehicle is bodied, the following minimum axle load(s) must be respected: A value corresponding to 26% of the weight of the unladen bodied vehicle kerb weight (with driver, without passenger)

LENGTHS

Wheelbase		mm	4.600
Body length	Min. (Wmin / BEP L105)	mm	7711
	Max. (Wmax / BEP L105)	mm	7898
Front Overhang	(H / BEP L016)	mm	1488



Telephone:
 Fax:
www.renault-trucks.com



Cab entry	(B / BEP L102)	mm	832
Wheelbase	(F / BEP L011)	mm	4600
Technical wheelbase	(F' / BEP L015)	mm	5285
Axle Spacing	Axle 2-3 (BEP L012.2)	mm	1370
Rear overhang	Chassis	mm	1575
Overall Chassis Length	(A / BEP L001)	mm	9033
Centre of Gravity of load	Min. (Ymin / BEP L104)	mm	504
	Max. (Ymax / BEP L103)	mm	598
Min Overall Length (Z)	(Zmin / BEP L001)	mm	10031
Max Overall Length (Z)	(Zmax / BEP L001)	mm	10218
Bodywork rear overhang	Min. (Xmin / BEP L017)	mm	3258
	Max. (Xmax / BEP L017)	mm	3445

HEIGHTS

Wheelbase		mm	4.600
Cab height (unladen)	(O)	mm	3291
Max. exterior height unladen	(BEP H001)	mm	3805
Side member height	(BEP H032)	mm	300
Ground clearance, laden	Front (U1 / BEP H015)	mm	365
	Rear (U3 / BEP H016)	mm	338
Frame top height at front axle	Unladen (H1 / BEP H035)	mm	1166
	Laden (H1 / BEP H036)	mm	1100
Frame top height at drive axle	Unladen (H2 / BEP H037)	mm	1193
	Laden (H2 / BEP H038)	mm	1126
Frame top height at the rear of the frame	Unladen (HN)	mm	1210
	Laden (HN)	mm	1142

WIDTHS

Wheelbase		mm	4.600
Max. cab width	(BEP W002)	mm	2492
Frame width	Front (BEP W035)	mm	1080
	Rear (BEP W036)	mm	852
Width at rear wheels	Rear axle 1 (V3 / BEP W003.2)	mm	2544
	Rear axle 2 (V5 / BEP W003.3)	mm	2544
Track	Front (V1 / BEP W013.1)	mm	2109
	Rear 1 (V2 / BEP W013.2)	mm	1874
	Rear 2 (V4 / BEP W013.2)	mm	1874

OTHER

Wheelbase		mm	4.600
Side member thickness	(BEP W034)	mm	13
Turning Radius	kerb to kerb	mm	9194.5
	Overall (BEP W012)	mm	9800



Telephone:
Fax:
www.renault-trucks.com



DXi11 ENGINE

Maximum power output: 280 kW at 1900 rpm.

Maximum torque: 1800 Nm from 1000 to 1400 rpm

6-cylinder in-line diesel engine - High-pressure fuel-injection (1700 bar) by pump injectors - 24 valves - overhead camshaft, rear-mounted timing

Bore 123 mm - stroke 152 mm - Capacity 10.8 L

Turbocharger

Electronically controlled fan

Direction of rotation (seen from G/B end): anti-clockwise

Sheet metal oil sump

EEC EURO III exhaust emissions level

Cooling liquid

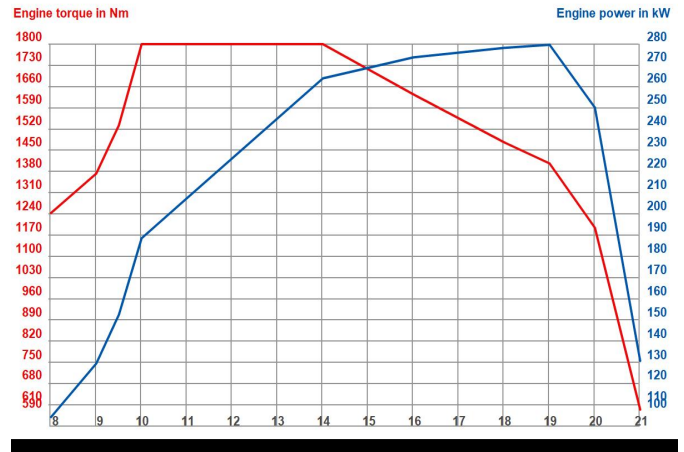

ENGINE EQUIPMENT

Cast iron engine flywheel casing.

Fast idling control whilst moving (muddy site)

Power mode is activated by passing the 'hard spot' at the end of the accelerator pedal stroke (kick down)

Automatic engine cut-off (5 min)

Without engine Power Take Off.

Electronic speed limiter (80 km/h).

CLUTCH

Single-plate clutch, diameter 430 mm

GEARBOX

Optidriver AT 2612F gearbox (14.94 - 1) with automatic clutch. Aluminium housing.

Max. torque 2550 Nm, 12 forwards gears and 3 reverse gears.

Steering wheel-mounted operating mode selection (automatic/manual) via gear shift selector.

Reinforcement of the Optidriver gearbox for heavy duty use (XTREM)

Heavy duty gearbox oil cooler, oil/water external heat exchanger

RETARDER

OPTIBRAKE (power rating 300 kW at 2300 rpm):

combination of the exhaust brake and valve compression braking, coupled to service brake

POWER TAKE-OFF

Power take-off S81

Output: splined hollow shaft (DIN 5462)

Direction of rotation: opposite to engine

Torque: 1000 Nm

Ratios: 0.71/0.90

Position: 18h

STEERING

Power steering, variable-flow hydraulic pump

Steering ratio 20:1 - Steering wheel diameter 460 mm

Driving on the right

FRONT AXLE

Front suspension and hub joints with grease nipples

Front load capacity (technical max.): 8 t

REAR AXLES

PMR 3361 drive axle with double reduction

Integral differential lock

Rear loading capacity (technical max.): 32 t

Rear load equally distributed

Drive axle ratio: 3.76

Engine speed at 90 km/h: 1645 rpm

WHEELS AND TYRES

Dimension 385/65 + 13 R22.5

Profile B. M748 EVO / L355 EVO

Steel disc wheels

Spare wheel and tyre supplied loose.

Service brake:

Twin-cylinder air compressor 900 l/min, 636 cm³

Braking system with two independent circuits

Drum brakes

Dust protection on rear brake

Electronic management of air production by EACU (Electronic Air Control Unit):

Dryer cartridge optimised by preventive maintenance.

Silencer on pneumatic circuit

Without rear trailer coupling.

High-position rear brake cylinders



Telephone:
Fax:
www.renault-trucks.com



EBS:

Hill Start Aid
Wheel anti spin regulation (ASR)
Brake pad wear balancing (discs)
Wheel antilock braking system (ABS)
Emergency braking assist (AFU)
Harmonisation of tractor and trailer braking
Brake performance warning
Coupling of retarders and service brakes

Parking brake:

EPB (Electronic Parking Brake) automatic parking brake, immobilization provided by spring cylinders
 Reinforced parking brake

Brake adjustment:

Automatic brake lining slack compensation.

Emergency brake:

Ensured by independence of main device circuits

CAB**Cab exterior:**

Day cab
 All steel Cab, electro-zinc plated and cathophoretic paint treatment.
 Cab paint colour: White ekla
 technical code: 09350
 Red badge
 Black front face finish
 Four point mechanical cab suspension.
2 heated, remote control rear view mirrors.
2 wide angle rearview mirrors.
Kerb view mirror.
 Rear view mirrors for bodywork up to 2.55 m wide
Fold-back front view mirror
 Air horn
 Front wing mudflaps
 Basic accessories: cab colour
 External sun visor
 Tinted, laminated windscreen.
 Tinted rear cab window

Cab interior:

Performance finish
 Quality roof console, 1 storage compartment with key lock, 1 storage space with net and 4 ISO modules
 Interior sun blind on windscreen
 Without tachograph
Manual roof vent
 Air-suspended driver's seat with fitted seat belt
 Two driver's armrests
Safety belt warning.
 Fixed passenger's seat with seat belt.
 Cloth seat trim.
 Removable rear storage compartment, left-hand side
 Reading lamps on overhead ledge
 Direct cab lighting
 Cab lighting time-delay.
 2 Coat hooks on rear panel
 Electrically operated door windows
Electronic air conditioning.
 Cab air filtration, washable filter
 Handbook and Service pack in French.
 2 loudspeakers.
Engine hourmeter.

Steering wheel equipment:

"Performance" 4-spoke steering wheel adjustable for height and depth, with control for cruise control
 OPTIDRIVER control
 OPTIBRAKE and retarder control on right-hand side
Easy Access steering column adjustable in 2 directions
 Mono CD player, MP3/WMA format-compatible
 Double tuner for immediate radio station list update
 Steering column-mounted radio controls
 Jack (3.5 mm) and USB inputs for MP3 player
 Hands-free interface for mobile telephone (Bluetooth technology), Audio streaming, steering wheel controls, microphone in the roof console, audio playback through vehicle speakers
 Information on the main information display



Telephone:
 Fax:
 www.renault-trucks.com



Instrument panel:

7" HD colour information display
 12V socket on dashboard, for accessories.
 Central locking with flip-out key
 Cruise control and speed limiter configurable by rotary control

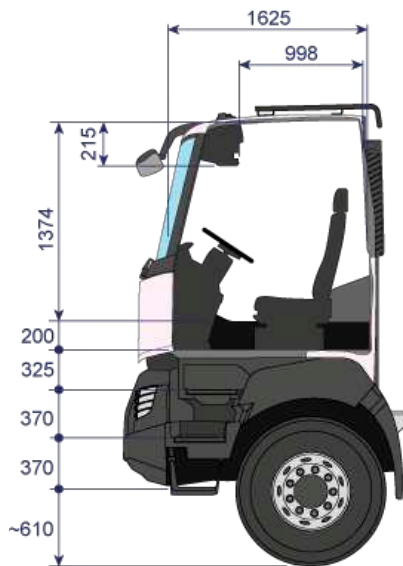
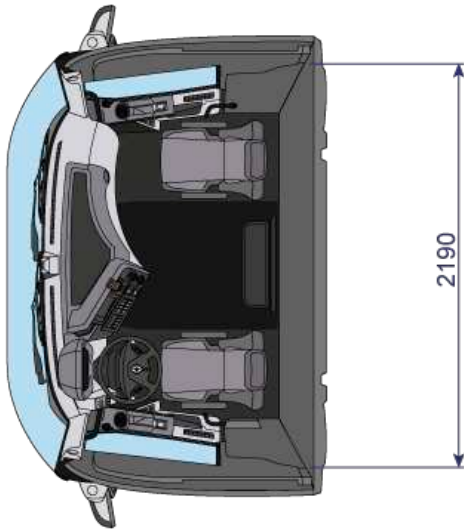
**ELECTRONIC EQUIPMENT:**

English and French language display
 Additional language (Spanish)
 SAE cab socket for vehicle data extraction
[FMS Gateway fleet management interface 3.0](#)
 4G TGW telematics unit (telematic gateway) including an antenna and enabling subscription to Optifleet services (Map, Check, Drive)

ELECTRICAL EQUIPMENT

Battery capacity: 185 Ah
 Batteries with level check
 Manual battery isolation
 Electrical circuit enters standby
 Alternator : 120 amp capacity.
 Rear signalling lighting.

CHASSIS

Chassis protective paintwork, mineral grey colour
 technical code: 03650
[Full chassis reinforcement, from front to rear of vehicle](#)
 Standard rear overhang, pre-drilled for bodybuilder
 Reinforced removable front towing cap
 Without rear under-run bar .
 Transmission crossmember Medium
 Closing cross member with pre-drilling for towing yoke
[Twin cartridge air filtration for dusty environments](#)
[Exhaust and vertical silencers](#)

BUMPER - STEPS AND LIGHTING

3-part steel bumper with headlight grilles
 Retractable windscreen access steps in radiator grille and under bumper
 Access to driving position by 4 steps. 1st step flexible and of composite material.
 Step lighting
[Reinforced cab access steps](#)
 Electrical headlamp levelling control.
 Lighting to EEC standards.
 Provision for lighting rail on front end
 Black fog lamp trims
[Two rotating orange lights](#)

SUSPENSION**Front suspension**

3-leaf reinforced front leaf springs
 Stabiliser bar

Rear suspension:

11-leaf elliptic suspension
 Stabiliser bar



Telephone:
 Fax:
www.renault-trucks.com



FUEL TANK

Main steel tank.
Main fuel tank: 315 litres capacity D560 profile mounted on right
Heavy duty fuel prefilter (R120), reinforced on chassis.

AdBlue

without AdBlue tank

STANDARD EQUIPMENT

Tool kit.
Jack 20t
Reversing warning buzzer, including night switch.
Windscreen washer bottle capacity: 8.8L

BODYWORK

Flexible bodywork attachment with springs
Body mounting brackets at the front and fastening plates at the rear
Bodybuilder access through bulkhead
Orange LED side marker lights with reflector
Interface for bodybuilder connections and BBM module (Body Builder Module)
Bodybuilder electrical interface on chassis
Electrical provision for crane

SPECIAL OPTIONS

REAR OVERHANG 2300 MM LAST REAR AXLE
CRANE BRAQUET 40T
FUEL TANK MOVE BACK 400 MM
AIR PRODUCTION UNIT INSIDE CHASSIS

SERVICE

Optifleet:

Pre-equipment for monthly Optifleet Check: technical data reports for fuel consumption monitoring by vehicle and by driver, activation of service on request subject to monthly subscription

Pre-equipment for monthly Optifleet Map: vehicle geolocation, geofencing and route analysis. Activation of service on request subject to monthly subscription

GEARBOX RATIOS

1	2	3	4	5	6	7	8	9	10	11	12
14.94	11.73	9.04	7.09	5.54	4.35	3.44	2.70	2.08	1.63	1.27	1.00

The manufacturer reserves the right to modify the specifications above without prior notice.

Non contractual document.

For further assistance please contact Product Applications at Renault Trucks UK Limited, Wedgnoek Lane , Warwick , CV34 5YA Telephone+44 (0)1926 475333.



Telephone:
Fax:
www.renault-trucks.com

