

VOLVO

HOOKLOADER T20 HEAVY DUTY PIONEER FMX

CONTRACT NUMBER: 09072020

NEW

ON REQUEST



SPECIFICATION

- Volvo FMX 400Ch 6x4 Rigid X-High Diesel engine
- 13 liters Euro 3, 400 hp
- 2000 Nm Euro 3 engine emission level
- Payload: 20.764kg
- Robotized gearbox I-Shift 12 gears
- Front axle load 9 tons
- Rear axles load 26 Tons
- Front axle tubeless tyre 315/80R22.5 - Bridgestone, M840 EVO
- Drive axle tubeless tyre 315/80R22.5 - Bridgestone, L355 EVO
- Wheelbase 3900 mm

OFFER INFORMATION

Location details

Köstendorf, 5203 - Austria 

Dealer Name

PALFINGER EMEA GmbH



Availability

On request

Product type

new

Contract number

09072020

Dealer E-mail

sales@palfinger.com

Dealer phone

004366488345792

PRODUCT

Manufacturer	PALFINGER	Constr. year	2020
		Configuration	6x4

TRUCK

Axes	6x4	Construction	Load lugger
-------------	-----	---------------------	-------------

FMX 400 HP 6*4 Rigid		
FO Number / OM Number		Print date
VSS-20-702202 /		2020-02-21
Firm planning date / Last Change Date	VIN Number	
/ 0 (YYYYWWD)		
Build week (YYWW)	Confirmed delivery day	Planned arrival date
202017	(YYYYWWD)	
Latest update		

Chassis Unique Homologation Document	General Homologation Document
LEGCHECK	

BEP, chassis unique drawing in scale

General chassis drawing:

- [FM64R3CTX_2011.dxf.zip](#)
- [FM64R3CTX_2011.pdf](#)

Data Sheet : [fm64r3ctx_global_engvt.pdf](#)

Supplementary drawing(s):

- POWER TAKE-OFF
[22885846_01.dxf.zip](#) [22885846_01.pdf](#)
- BODY ATTACHMENT
[3200308_03.dxf.zip](#) [3200308_03.pdf](#)
- EXHAUST SYSTEM
[3200318.dxf](#) [3200318.pdf](#)
- SPAREWHEEL CARRIER
[3200345.dxf.zip](#) [3200345.pdf](#)
- CAB-DAY
[3200351\[1\].zip](#) [3200351.pdf](#)
- FRONT MOUNTED EQUIPMENT. RADAR ZONE.
[FMX_Front Radar Keep-out-zone.zip](#) [FMX_Front Radar Keep-out-zone.JPG](#)

Tyres front	Tyres rear
315/80R22.5 BRIDGESTONE M840 EVO	315/80R22.5 BRIDGESTONE L355 EVO

 Latest updates

Technical Specification

ADMINISTRATION	
Variant	Description
URH	Without roof hatch
UL-FUEL	Without left diesel tank
R415S56	Right 415 litre steel 560 mm high D-shaped diesel tank
MIRSTDX	EI heated robust main rear view mirrors and wide angle mirr (both sides). Close view mirr pass side.
UDRIVE	Without driving package
UTACHO	Without tachograph
8WA-MSP	West Africa
SS19W51	Pricelist Period 19W51-20W10
BC-FMX13	FMX13 model for Business Control
FMX1364R	FM 64 R ENG-VE13
UASAFE	Without active safety package
FMX64R40	FMX 400 HP 6*4 Rigid
XHIGTR	X-high chassis height with T-ride
ULSA	Without local sourcing
USWUR	Remote software upgrade disabled
UDFFAM	Without Fuel Advice
UDRUT	Without My Truck app
URESERM	Without remote service message
TC-CONST	Construction transport cycle (driving pattern)
UDFVH	Without dynafleet vehicle status service
MFACTBEL	Main Factory Belgium
UPVTS	Without preview topography service
UBODYPK	Without Body Builder preparation package
EU3	Euro 3 engine emission level
UDFFUEL	Without Dynafleet Fuel & Environmental service
UDFDTM	Without Dynafleet Driver Times service
UDFPOS	Without Dynafleet Positioning service
UDFMSG	Without Dynafleet Messaging service
8AF	Market area Africa
WB4300	Wheelbase 4300 mm
CLASHDV	Classic Heavy Duty Vehicle, Volvo
24-HDV	New generation Volvo heavy vehicle
FM 64 R	FM 6x4 Rigid
DIRT-HIG	Much dirty roads/surfaces

UEGR	Without exhaust gas recirculation
TYPE-FM	FM Low tilt cab
UWVTAPPR	Without Whole Vehicle Type Approval, EC
6*4	6x4 - Three axles, two axles driving
RIGID	Rigid model
RC-ROUGH	Rough road conditions
GCW70.0	Gross combination weight 70.0 tonnes
ENG-VE13	12.8 litre six cylinder engine
VH4.5	Total vehicle height max. 4.5 metres
RAL32	Rear axles load 32 tonnes
STWPOS-L	Left hand drive
VW2550	Vehicle width 2550 mm
FAL9.0	Front axle load 9.0 tonnes
UADR	Without ADR adaptation (transportation of dangerous goods)
MA-BAS	Basic market adaptation
CHH-XHIG	Chassis height extra high - approx. 1030 mm above ground level
UCONSAFE	Connected safety disabled
ALTI2500	Altitudes up to 2500 metres above the sea level
J1E-AAX	PROCESS A FOR CLASSIC 24-HDV
COG-BAS	Complete superstructure & payload centre of gravity between 0.5 m and 1.0 m above top of truck frame
CURV-L	Low curve density (the speed is seldom reduced due to driving in curves)
UVUPT	Vehicle uptime settings disabled
NR-BASIC	Without exterior noise requirement
UCONBOS	Without subscription connected bodies
DTECH-CO	Combustion driveline technology
EFC-LQ	liquid fuel
UADRC	Without ADR classification
ULEGC	Legislation check disabled for order
B-HOOKL	Hook lift
ULHE1	Without tail lift
ULHE2	Without crane
ULHE3	Without snow plough
ULHE4	Without miscellaneous load handling equipment
T-PFLAT	Predominantly flat topography
UVASSIST	Vehicle assistance service disabled
RFUEL	FICTIOUS VARIANT RIGHTHAND FUELTANK (ALL SIZES)
UWVTA	Not Whole Vehicle Type Approved
RT-STEEL	Steel rims on all axles
F315-80A	Front axle tubeless tyre 315/80R22.5
D315-80A	Drive axle tubeless tyre 315/80R22.5
UPHTRI11	Seat with grey text ins&vinyl bolster, red vinyl side ins&vinyl/text inter trim in skylark/grey/blac
UOFFROAP	Without construction package
UMBAC	Without market business package
ESH-LEFT	Horizontal muffler, left exhaust outlet
FMX-DAY	FMX Day cab
URESTING	Without living package
AUBAS	Audio basic. RDS radio/CD, FM/AM ant & dash/door speakers. Prep for Dynafleet office portal support.

ENGINE WITH MOUNTING AND EQUIPMENT

Variant	Description
UADTP	Without AdBlue tank position
UTFUEL	Without temporary diesel tank
UOBDEC	Without high emission level consequences
UOBDEP	Without OBD emission phase regulations
PRIM-MAN	Manual priming pump for fast and easy bleeding of the fuel system
FTCL-BAS	Fuel tank with basic ground clearance
UWILDBAR	Without wild bar
UFTI	Without fuel tanks interconnection
OILS-ST	Steel oil sump
TURB-HD	Turbo heavy duty design
HS-BAS	Basic muffler heat shield for all emission variants
CCV-O	Open crankcase ventilation
UADB	Without AdBlue tank volume
FUEFE2LW	Large engine mounted dual fuel filter with water separator and drain. For poor fuel (outside WestEu)
XFUEL50	Extra fuel filling 50 litres
ATL15	Ambient temperature down to -15 degrees C
UISD	Without idle shutdown time

ATU-VH	Ambient temperature above +40C
UFUFF	Basic fuel filling
UFUEQWH	Without fuel line heater
DIESEL	Diesel fuel
TURBO-S	Turbo single stage
UETEC	Without engine temperature control - Extreme conditions
<u>BUGNET</u>	<u>Radiator screen / Mosquito net (PVC coated fibreglass) in front of radiator</u>
<u>D13A400</u>	<u>Diesel engine, 12.8 litre Euro 3, 400 hp, 2000 Nm</u>
ETOR2040	Engine torque range 1981 - 2040 Nm
<u>EBR-VEB</u>	<u>Volvo Engine Brake, VEB (compression brake with exhaust pressure governor, EPG)</u>
EAP-LHD2	Light heavy duty engine application (std pistons and corrosion resistant valve seats)
RFN-B	Filler neck rear of the fuel tank
UAUXFUEL	Without heated fuel filter
USPEEDDU	Without dual speed limiter
SPEED90	Road speed limiter setting 90 km/h, EC
<u>CRUISEC</u>	<u>Basic cruise control with controls in steering wheel</u>
FAN-VICE	El. temperature controlled cooling fan
<u>AIRIN-HI</u>	<u>High air intake</u>
ULGAS	Without left side gas tank
A-FREE25	40/60 mix coolant and water (- 25 Celcius)
FUELTS56	D-shaped 560 mm diam fuel tank
TNK-SING	Single mounted fuel tank
FTANK-ST	Steel fuel tank
<u>FCAP-L</u>	<u>Lockable diesel and AdBlue tank caps</u>
STRAP-P	Painted fuel tank straps
UEXST	<u>Without vertical exhaust</u>
UEXSH	Without extra exhaust heat shield
UEAS	Without exhaust particulate filter
EM-EC01	Emission level Euro 3
<u>ACL1ST-S</u>	<u>Air cleaner with additional filter element</u>
UDPFREGC	Without diesel particulate filter regeneration controls
URSPED	Without remote speed limiter
ULICPLH	Without license plate holder
UCSPEED	Without customer reduced road speed limiter
USPLIMS	Without speed limiter sensor
USCRS	Without SCR system equipment
UFUELB	Without fuel blend
UPADB	Without percentage of AdBlue filling in tank
ULFFUEL	<u>Without diesel plastic fuel tank</u>
CPSR-FIX	Fixed coolant pump speed ratio
EASO-H	Horizontal orientation of the aftertreatment system
UADTC	Without AdBlue tank cover

ELECTRIC POWER SUPPLY, LIGHTING, INSTRUMENTS

Variant	Description
UHWSS	<u>Without headway support system</u>
UARLIG	Without additional rear lights
URSENSW	Without wiper rain sensor
UTAS	Without tachograph
<u>INLI-BAS</u>	<u>Interior white light with smooth light transition at on/off, no dimming</u>
URESTS	Without reflecting white stripes on chassis side
ACCLF-D	<u>Volvo torque assist - Disabled</u>
UALCOLOC	Without alcolock
24V	Electrical system 24V
UDAS	Without Driver Alert Support (without drowsy driver warning)
UPHONE	Without telephone or telephone preparation kit
HL-ASYMR	Headlamp alignment set for right hand traffic
DETECT-S	Smoke detector in cab
HORN-ELS	Single electrical front horn
<u>HORN-F1S</u>	<u>One front mounted (behind grille) single tone air horn, Jericho. Operated by steering wheel buttons.</u>
URTOLL	Without road toll equipment
UCONBO	Without connected bodies
USOUTLET	Without electrical outlet in sleeper compartment
UFMS	Without fleet management system gateway
TWEETER	Tweeter
<u>ECBB-HIG</u>	<u>Body builder electrical centre with cab body builder module</u>
SIDT-B	Basic type of secondary information display

POSMLP-W	Two white front roof mounted position lamps (end outline marker lamps, LED on FH)
AUDS-A	Audio signal - AM/FM
UASL	Without spot lamps in sign box
WWF-ALC	Windscreen washer fluid with alcohol additive
UWLAMP	Without working lamp
BEACON-P	Prepared wiring (switch and connected relay included) for warning lamps on cab roof
SPG-KM	Speedometer scale kilometres per hour
UESTAID	Without pre-heating element
TL-LED	LED tail lamps
MSWI-C	Chassis main switch - battery box placed toggle switch circuit shut down
UFOGLAMP	Without front fog lamps
UDRIVL	Without auxiliary front driving lamps
UAUXL	Without snow plough preparation kit
UHLADJ	Without headlamp adjustment
UHLCLEAN	Without headlamp cleaner
UIMMOBIL	Without immobiliser
UIDLAMP	Without identification lamps
MARKL-SR	Side and rear marker lights
USRL	Without chassis working lamps
DIFL-FRA	Driver information first optional language - French
UDISL	Default second optional language, English
SAS-INFO	Service alert system
HL-BAS2	Halogen H1 head lamps (heavy duty)
24AL110B	Alternator 110 Ampere
SI-SPEED	Speedometer instrument, odometer
UTGRAPH	Without tachograph
CALI-BAS	Basic calibration of tacho. & speedometer
UNAVS	Without navigation system
BATTD128	Battery density, 1.28 acid solution
UASSIST	Without assistance
USPOTP	Without spotlamp preparation
USINF	Without service and infotainment
BATS-S	Single energy battery storage system (2 batteries)
ULOADIND	Without load indicator
UTAMA	Without tachograph market area preparation kit
UALARMB	Without burglar alarm
UAUXSW	Without wiring for extra switches
INST-MED	Medium level instrument cluster - 4 inch colour display 240x320 pix
AUD-CDB	Radio with CD player
BATTAMP	Battery voltage and ampere gauge
UEXSTER	Without support for external steering control via body builder module
DRL-LED	V-shaped ("V-light") day running light (LED)
SID-BAS	Dashboard integrated monochrome information display, 75 x 735 pixels / 150(W) x 30(H) mm
EWT5000	Equivalent wheelbase turning, 5000 mm
BLIGHT-B	Basic brake light
UBATTREC	Without battery reconditioner
URPLCR	Without rear position lamp
BBOX-L	Battery box on left hand side
2BATT170	Batteries 2x170 Ah
UAMPL	Without external amplifier
UCLSTAT	Without cornering lights
BAMAFREE	Enhanced flooded batteries extra
UBEPREP	Without body builder software electrical preparation
UWLC	Without working lamps back of cab
TD-BAS	Trailer detection without LED sensor
UAHS	Without automatic headlamp switching
BBCHAS3	Three 7-pole connectors for Body builder interface
TLB-BAS	Basic tail light brackets
UANTCB	Without antenna for CB radio (no antenna attachment)
SPK-DADO	Loudspeakers in dash & doors
UAIP	Without audio integrated handsfree phone
UACON	Without USB audio communication connector
UXCON	Without audio AUX Line in connector
UAESW	Without Body builder electrical switches
TGW-PK	Telematics gateway preparation kit
HLP-ST2	Steel wire mesh headlamp protection

UREMCON	Without wireless remote control
BUPALARM	Back-up alarm
UARL	Without flexible reading lamps
UINFOT	Without TV mounting preparation kit
UBUPMON	Without back-up monitor
UDRID	Without telematics driver ID with USB
ULSS	Without lane keeping support
ULCS	Without Lane Change Support
UARSL	Without additional road speed limit
AUDWB1	Audio wavebands FM 87,5-108,0 MHZ, AM 522-1611 KHZ
UMAPR	Without map region for navigation
UBULBKIT	Without bulb and fuse kit
ULAMPIN	Without inspection lamp

POWER TRANSMISSION

Variant	Description
GSS-AGS	I-shift lever gear selector
URSO	Without extra reverse gears
UPTER	Without rear engine mounted PTO
TC-MAOH2	Extra high performance cooler for manual/I-shift gearboxes - air/oil
UPTOENGR	Without rear engine mounted PTO
PTR-DH	Mech. gearbox driven high speed PTO, 1 rear conn. (DIN 5462/ISO 7653 for plug-in pump (max. 600 Nm)
RAT4.12	Rear axle ratio 4.12
PROPS-LE	Prop. Shaft Large - Extended 180 mm diameter
PSM1	Propeller shaft manufacturer Dana Spicer
DL-FULL	Differential lock between axles and wheels
UPVT	Without topography information
UEPTT	Without engine power take-off torque capacity
TRAP-BAS	Basic gearbox application
HRED-V	Hub reduction rear axle
RTH3210F	Rear hub reduction tandem axles - bogie load 32 tonnes. GCW 100 tonnes. version F
CS43B-O	Single plate clutch, plate diameter 430 mm
TRA-AMT	Automated mechanical gearbox
AVO-ENH	Enhanced I-shift software for construction and off road applications
TP-CON	I-shift construction gear changing software
APF-BAS	Basic I-shift PTO functions
UASO	Without crawler gears
TPTT600	Gearbox power take-off torque capacity 600 Nm
TTOR-B	Basic transmission output torque
AMSO-AUT	I-shift manual gear shift available in automatic mode incl kickdown function
AT2612F	I-Shift automated mechanical 12-speed gearbox without clutch pedal, 2600 Nm, GCW 100000 kg

BRAKE

Variant	Description
ATANK-ST	Steel air tanks
UESPFC	Without ESP (Electronic Stability Program) functionality control
FBRA175	Front axle brake lining 175 mm
UTBRD	Without tag axle brake
RBRA200	Drive axle brake lining 200 mm
UTBRA	Without tag axle brake dimension
BSYS-EBS	Electronic brake system
DBRDUST	Dust shield for rear brakes
UAUXPARK	Without extra parking brake
BRAKE-ZV	Volvo Z-cam brakes
FBREG-E	Front axle regulating brake valve for EBS
URETARD	Without retarder
UAUXATNK	Without extra air tank
2COMP900	Dual cylinder air compressor 636 cc
TRBRAKE	Trailer brake valve
UTCP	Without trailer connection bracket position
TRBR-STA	Stationary trailer brake control
ABS	Lock free brakes
UESP	Without Electronic Stability Program package
UTRACON	Without trailer light converter
UTABS	Without trailer ABS circuit converter
UPBRAD	Without pusher axle disc brake dimension
UCLUAIRC	Without clutchable air compressor
PBREL-A	Automatic parking brake release

UTECABLE	Without electric cable for trailer brake
UTBCONN	Without trailer brake connection
TREL7-7	2x7 pol (24N+24S) electrical trailer connectors (UADR)
PNPROT	Protective cover for chassis mounted pneumatic equipment
UTBHOSE	Without trailer brake connections
EBS-MED	EBS (Electronic Brake System) medium package
UTRBSTRE	Without low speed automatic trailer brake activation (stretch brake)
PDC-OFF	Pneumatic distribution center location - outside frame, front
BF-DRCAS	Drum brakes

WHEEL SUSPENSION AND STEERING

Variant	Description
UTAAXLIF	Without tandem axle lift
UASFE	Without Volvo Dynamic Steering
PSS-SING	Single power steering system
STGW-ADJ	Mechanically adjustable steering wheel
ULDFA	Without load distribution on front axles
URALIM	Without first rear drive axle load limiter
ULIFT	Without bogie lift
UAUXPSP	Without extra power steering pump
URVCERT	Without vehicle certification, road
UBCYLPRO	Without brake cylinder protection
RADD-TR2	Rear leaf suspension, 2 axles - 2 driven (Max. technical boogie load 32 tonnes)
FA-XHIGH	Front axle extra high ground clearance
FAA10	One front axle, not driven
URSTS	Without rear steering system
UACTST	Without active steering
BL-EQL	Equal bogie load sharing across all axles
PSP-FIX	Power steering pump with fixed displacement
STW-D450	Steering wheel with diameter 450 mm
U1PAC	Without first pusher axle capacity
U1TAC	Without first tag axle capacity
STWM-BAS	Standard steering wheel material
STG20.0	Steering gear ratio 20.0

FRAME, SPRINGS, DAMPING AND WHEELS

Variant	Description
WTDF22.5	Front wheel and tyre inner diameter 22.5 inches
WTDD22.5	Drive wheel and tyre inner diameter 22.5 inches
UWTDT	Without tag axle wheel and tyre inner diameter
UTWT	Without tag axle wheel type
UWTTM	Without tag axle wheel and tyre mounting
WMF-ST	Front steel rims
WMD-ST	Drive steel rims
UWMT	Without tag axle rim material
WDF900	9.00 inch front axle rims
WDD900	9.00 inch drive axle rims
UWDT	Without tag axle wheel dimension
INFLAHOS	Tyre inflation hose (18 metres) with nozzles in both ends
UTIREPM	Without tyre pressure monitoring
UTT	Without tag axle tyre
TMF-BRID	Bridgestone front axle tyre
TMD-BRID	Bridgestone drive axle tyre
UTMT	Without tag axle tyre
TR-AFR2	Tyre region Central Africa
UFSLs	Without air suspension levelling stroke
UASF	Without air suspension driving level feature
GUARD-EH	Guard plate for cooling pipes and oil sump
SWCP-LF	Spare wheel carrier on left side in front of rear axle
SPWT-F	Spare wheel with tyre equal to front wheel
FSI-LEAF	Front leaf suspension
UGAUGETP	Without tyre pressure gauge
UARSTA	Without additional rear stabilizer
URUPP	Without rear underrun protection pos.
WTA-TL	tubeless tyres
WSTUD-S	Short wheel studs (alu dual hol)
UTMPR	Without pusher axle tyre
URSLS	Without rear air suspension levelling stroke (for leaf suspension)

XMBRR-B	Basic rear crossmember closing
UMRUP	Without rear underrun protection
<u>FSM-LUB</u>	<u>Lubricated front suspension pins and bushings</u>
UWCAP	Without wheel caps
USUPS	Without steps in side underrun protection
UTRTT	Without tag axle tyre tread
UPTT	Without pusher axle tyre tread
UFUP	Without front underrun protection
UWTDP	Without wheel and tyre diameter on pusher axle
UFRF	Without frame rail clearance
RSAP-BAS	Standard rear suspension application (without reinforcements)
UFALIM	Without front axle load limiter
PROTC-I	Improved corrosion protection level
UTWP	Without pusher axle wheel type
UWDP	Without pusher axle wheel dimension
URESTRUP	Without reflecting red stripes on rear underrun protection
UFRACLOS	Without frame end closing
TXMB4827	Transmission crossmember web location (main 4827)
<u>RFEC-S</u>	<u>Rear frame end, straight cut (for regular platform applications)</u>
XMBT-S	Strong transmission crossmember
FST8080	<u>Frame section thickness - web 8.0 mm / flange 8.0 mm</u>
FRAME300	Frame rail section external height 300 mm
<u>RFL2195</u>	<u>Rear frame length 2195 mm from 1st drive axle</u>
URUP	Without rear underrun protection
<u>FST-PAR3</u>	<u>3 leaf front parabolic suspension (stiffer than normal)</u>
RST-MUL	Rear conventional multi-leaf suspension
FSS-LEAF	Front leaf suspension
RSS-LEAF	Rear leaf suspension
FSTAB2	Front stabilizer with medium high stiffness
USUP	Without side underrun protection
RSTAB1	Rear stabilizer with normal stiffness
<u>FIL-TXEB</u>	<u>Frame inner liner from transmission cross member to end of bogie</u>
USUSPLEV	Without suspension levelling

BODY, CAB AND INTERIOR

Variant	Description
UEBHEAT	Without electrical engine block heater
FMUDE-B	Front mudguard extension, basic
UCSPL	<u>Without storage in lower center dash panel</u>
UARMRU	Without armrest upholstery
GRABHI-B	Steel instep grab handle
UCPR	Without cab roof protection
UCLEQ	Without extendable windscreen cleaner
UBUMPSP	Without front bumper spoiler
UTBL	Without left toolbox
UTBR	Without right toolbox
USBPREDS	Without driver seat belt pretensioner
<u>JACK-20T</u>	<u>Jack 20 tonnes</u>
<u>TOOLKIT</u>	<u>Extended tool kit</u>
RUSTP-T	Full transport rust protection, 3000 ml wax
UEMBO	Without emblem options
DGLAS-H	Tempered door glass
UCOFMAK	Without coffee maker
USTUC	<u>Without storage compartment under cab</u>
UWRNLAMP	Without portable warning lamp
USBPREPS	Without passenger seat belt pretensioner
UGLASC	Without glass coating on side windows
<u>1103WHIT</u>	<u>Cab colour solid Winter White (NCS 1202-Y03R) / Solid clear coat = 7103WHIT</u>
<u>PAICS-B</u>	<u>Basic painting in a lightning grey colour of mirror housings, insteps and bumper</u>
UWLOCK	Without window control lock
ULADDER	Without ladder back of cab
UKEYF	Without radio communication channel
EMBL-MO	Mounted emblems
UBOTTLEH	<u>Without bottle holder</u>
UMICROWV	Without microwave equipment
SUPH-VT	<u>Seat upholstery - black embossed textile insert, black vinyl bolster and red vinyl side insert</u>
UTABLE	Without foldable table

CABPT-R1	One front cab roof pass through on passenger side
UWARVEST	Without warning vest
UAIRBAG	Without airbag
URUS	Without rear cab upper storage
UOLMAT	Without overlay mattress protector
UWRITEP	Without writing pad
USIGNS	Without green and safe signs in front
URLS	Without storage under bunk
UVANMIR	Without vanity mirror
UMATTRES	Without lower mattress
DLAY-BAS	Basic dashboard layout
DTRI-RAV	Dashboard in black/raven
TOP4	Transmission oil STD 1273,15. Thick synthetic oil. Needs filtering and cleaned transmission.
UCFAFS	Without foldable extra front cab foot-step
HCC-EXT	Unlockable front lid - Exterior hood catch control
SBD-BAS	Black safety belts, passenger and driver seats
SBP-BAS	Black safety belt, passenger seat
UADH	Without roof aerodynamic device height
UCPARKC	Without cab parking cooler
UADCF	Without additional flap on chassis fairings
UAIDKIT	Without first aid kit
ISUNF-B	Interior front plastic sun visors (driver and passenger side) without mirror on driver side
UAUXFS	Without extra cab side foot-step
USIMC	Without sim card
CSPT-T	Center section dashpanel top, tray
PUBS-FRA	Driver's handbook in both local language and French
EXTL-BAS	Basic exterior finish in a lightning grey colour of mirror housings, insteps and bumper.
UTBUNK	Without top bunk
UIDLMPSW	Without switch for identification lamps
CSPU-S	One open storage (behind push open lid) in upper part of dash panel center section
UAWINDR	Without rear window
UROHO	FH: Non opening sky window (tinted glass)/emergency exit (with emerg hammer). FM: Without roof hatch
UCABSIGN	No cab sign decal. FH,UCABSIGN,ROS-IL/ROS-ILP=white area. FH,UCABSIGN,UROSIL=black. FM=white area.
UEMIEMBL	Without emission emblems
CAB-DAY	Day cab
RCABS-M	Mechanical rear cab suspension
CTILTP-M	Manual cab tilt pump
UADFS	Without extra DIN slots in front shelf (blind slots)
FMUD-AS	Mudflaps with anti-spray on all front axle fenders
USIDESTP	Without side foot-step and handle
FCABS-M	Mechanical cab suspension
UAWINDS	Without rear side window
WLIFT-ME	Mechanical window lift on both sides
URHATCH	Without roof hatch
GLAS-TIN	Tinted windows (front/side/rear)
ULBK	Without lower bunk
FMAT-RU2	Two black rubber floor mats with raised edges and an extended side (FMX)
PST-BAS1	Passenger seat, basic, non suspended
CABH165	Cab height 165 cm
UACCBKRT	Without roof mounted accessory bracket
UREFS	Without reflecting stripes on cab
LANG-EF	English/French text on decals/signs
PUBL-GBR	English publication language
UCERTLAB	Without certification labels
LOCK-MAN	Manual door locking
UREFL	Without reflectors
DPAN-B2	Door panel in red vinyl (electric window lift) or black (raven) plastic (mechanical window lift)
UMATINS	Without insert mat on engine tunnel
AMIR-WB	Wide angle mirror on both sides
AMIR-F20	Front close view mirror above windscreen, passenger side (radius 200 mm)
TRIM-RB	Vinyl interior trim in matching grey nuances
UARMREST	Without armrests on driver and passenger seats
UROSIL	Without illuminated roof sign
DST-CF1	Driver seat, comf, susp
FIREXT3S	Fire extinguisher 3 kg, Swedish/English decal
UPARKH	Without parking heater

AMIR-S30	Close view mirror on passenger side, radius 300 mm
ISUNS-DS	<u>Manually manoeuvred side interior sun visor (roller blind type) on driver side</u>
UAS	Without extra shelves in front rollfront compartments
CU-MCC	<u>Electrical manually controlled air conditioning</u>
UACU	Without additional climate unit
UDFHFP	<u>Without Dynafleet Positioning+ service</u>
BUMP-HD	<u>Heavy duty front bumper</u>
TOWF-HD1	<u>One heavy duty front towing device</u>
UWINREP	Without cab side window replica
UBEDNET	Without net for lower bunk
USAFETYB	Without safety box
MPLA-ENG	Manufacturing plate, English version
USLCP	<u>Without sleeper control panel</u>
SUNV-H	<u>Exterior transparent dark grey front sun visor</u>
UXSEACAB	Without extra cab sealant material for dust tightness
UADROOF	Without roof air deflector
UADSIDE	<u>Without cab side air deflectors</u>
UADCHAS	Without chassis side skirts
UWARNTRI	Without warning triangles
UMIRRTXT	Without mirror text
UETSBOX	Without engine tunnel storage
UREFRIG	Without refrigerator
USIGN	Without front cab sign
XINS-CAB	<u>One extra layer of cab insulation</u>
UGUARDW	Without windscreen stone guard

Miscellaneous

Variant	Description
UFFEND	<u>Without fenders on second front axle</u>
COD-CIV	Destination country Ivory Coast, national frequencies
CG-AF1	Destination country group Africa 1, national frequencies
URFCAR	Without rear fender carrier
URMUDF	Without rear axle mudflaps
URFENDER	Without rear fenders
UFWPOS	<u>Without fifth wheel position</u>
U5WMOUNT	<u>Without fifth wheel mounting</u>
U5WHEIG	<u>Without fifth wheel leg-height</u>
UKPSIZE	Without king pin size
U5WTYPE	<u>Without fifth wheel</u>
URAMP	<u>Without sliding members/protection members</u>
UTOWTYPE	Without towing member
UTOWMBR	Without towing member
UCOUPLIN	Without towing coupling
TOWR-ONE	<u>One rear towing device in frame end cross member</u>
UWHCHOCK	<u>Without wheel chocks</u>
URDECK	Without rear deck
UTAIL	<u>Without tail lift preparation</u>
UHPG	Without gearbox mounted hydraulic pump
UFFTP	Without second front axle fender top height
TIPP-PRE	Tipper vehicle preparation
ULCHF	Without load carrier
ULCL	Without load carrier length
RFC-2	Fender & front underrun calc. exempted from EC front underrun and anti-spray requirem (NG3 off-road)
RFH-BAS	<u>Optimal fender installation (rear and 2nd front axle)</u>
U5WLM	<u>Without fifth wheel maintenance</u>
FACT-BEL	Final assembly plant Belgium
7800MM	Frame length 7800 mm
UCHAGH	Without chassis grab handles
UCHAINS	Without snow chains
UTMP	Without towing member position
UFFQP	Without second front axle quarter fender mounting position
UCROSSRE	Without cross reinforcement for swapbody
U5WLUB	<u>Without fifth wheel lubrication</u>
UTCIND	Without trailer connection indication
HBA-FSFB	<u>Holes for body attachments, flexible/semi-flexible body</u>
UHOOKSC	Without snow chain hooks
UPSCAT	Without propeller shaft catcher

UCRANEPK	Without crane plates
SDC-BAS	Steering demand calculation according to internal requirements
FBA-BTSF	Lower front body attachments for torsionally semi-flexible body (van or curtainsider)
RBA-T2	Lower rear body attachments for helper frame
UHPE	Without engine mounted hydraulic pump
UWHCP	Without wheel chock position

List of warnings/errors (0 message):

No restrictions violated

Application version: 155, EDB library version: 342.0.0 Elapsed: 2.90 seconds Built: Sep 24 2019, 14:25:49

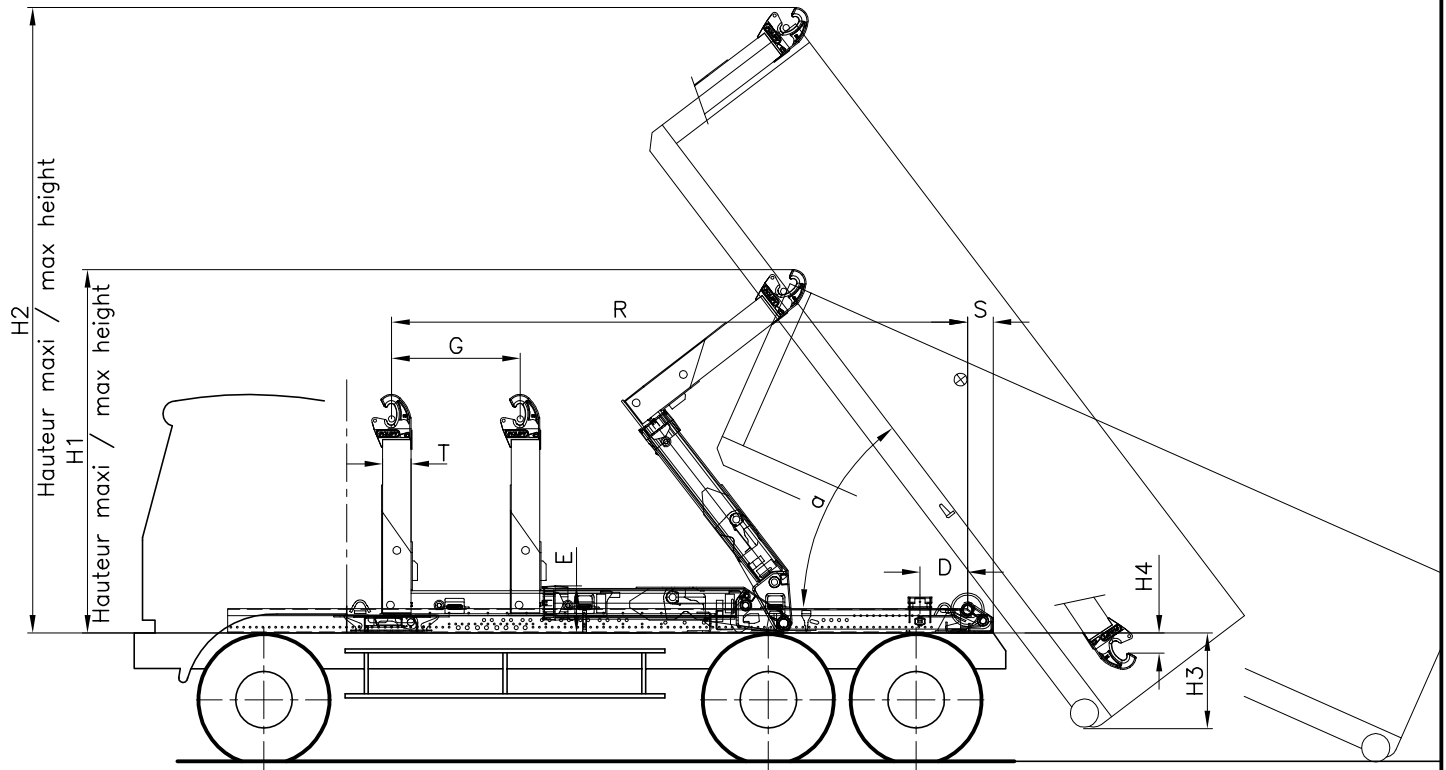
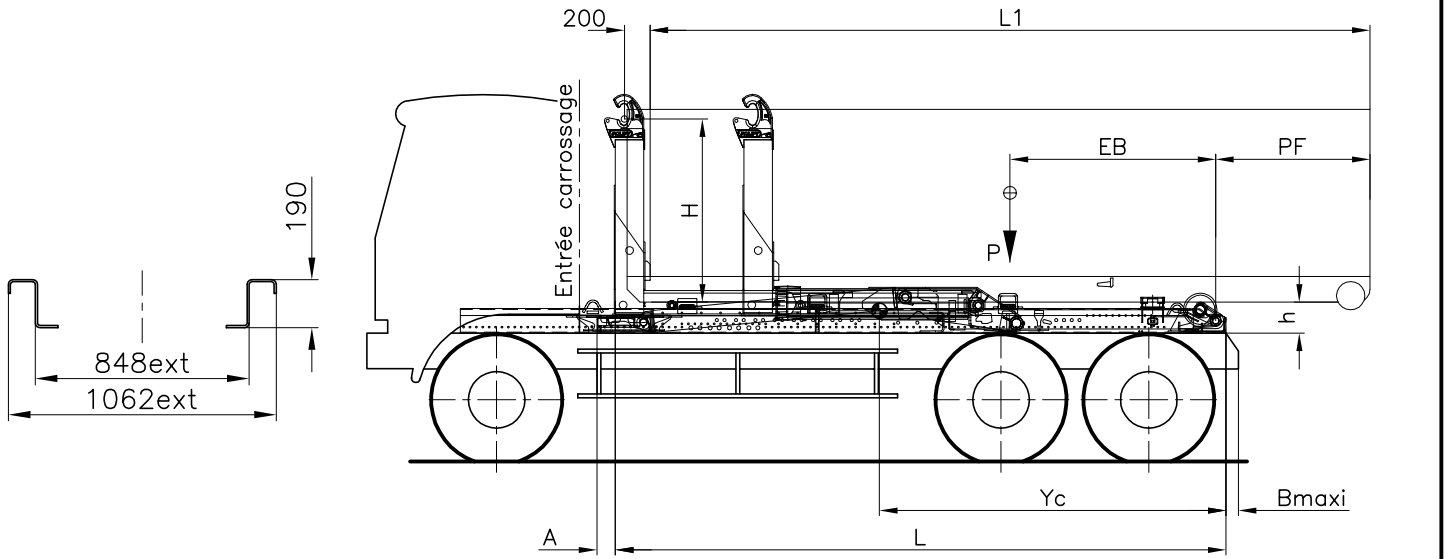

Hauteur d'anneau / Hook height	H(mm)	1425
Largeur de berce / Cradle external width	J(mm)	1060
Hauteur de berce / Cradle height	b(mm)	180/200
Hauteur du tunnel / Tunnel clearance	t(mm)	180
Déport d'anneau / ring offset	A(mm)	200
Diamètre de l'anneau / ring diameter	E(mm)	50/60

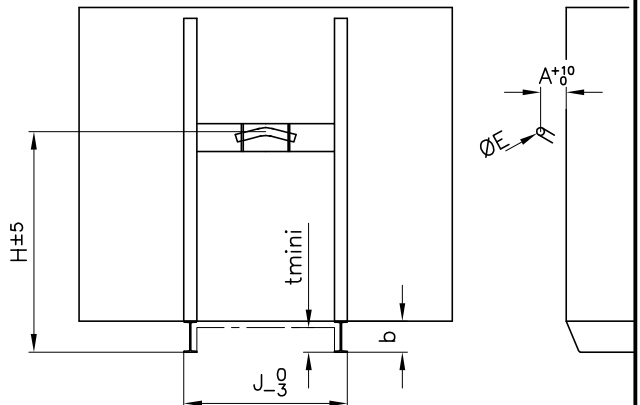

Benne/Container

Haut. d'anneau / Hook height : 1425
Haut. de châssis / Chassis height : 1100

REFERENCE	Long./length Eqipt.	Entr'axe base
M11_02580_04	4750	1505
M11_02580_04	4900	1555
M11_02580_04	5100	1655
M11_02580_04	5300	1755
M11_02580_04	5500	1855
M11_02580_04	5650	1905
M11_02580_04	5850	2005
M11_02580_04	6000	2155
M11_02580_04	6150	2205
M11_02580_04	6300	2255
M11_02580_04	6450	2305
M11_02580_04	6600	2355

MAXI	
Bras sorti / Arm out	
L1 maxi *	Porte à faux bascul./tipping overhang
5800	1395
6000	1445
6200	1445
6400	1445
6600	1445
6800	1495
7000	1495
7000	1345
7200	1395
7400	1445
7600	1495
7800	1545

MINI*	
Bras rentré / Arm in	
L1 mini *	Porte à faux bascul./tipping overhang
3600	196
3800	246
4000	146
4000	146
4200	196
4400	246
4400	246
4400	96
4600	146
4800	196
5000	246
5000	246

MINI AV**	
Bras sorti / Arm out	
L1 mini *	Entr'axe base
4600	2105
4800	2155
5000	2255
5200	2355
5400	2455
5400	2605
5600	2705
5800	2755
6000	2805
6200	2855
6200	3005
6400	3055

* sous réserve de vérification de la répartition des charges en fonction du véhicule / These dimensions must be confirmed by the vehicle load distribution

** Equipement avec verrouillage hydraulique arrière / Unit with rear hydraulic locking

Equipement/Equipment

REFERENCE	Long./length Eqipt.	Crochet à Poulie/hook to pulley		Cotes de l'appareil / Equipment size				Angle bascul. / tipping angle	Dépassement Av. / front exceeding		
		L.	R	T	D	S	G	a	A		
M11_02580_04	4750	4485	270	370	200	1001	53°	270			
M11_02580_04	4900	4635	270	420	200	1001	50°	270			
M11_02580_04	5100	4835	270	620	200	901	48°	270			
M11_02580_04	5300	5035	270	620	200	1101	48°	270			
M11_02580_04	5500	5235	270	620	200	1151	50°	270			
M11_02580_04	5650	5385	270	770	200	1151	48°	270			
M11_02580_04	5850	5585	270	770	200	1351	48°	270			
M11_02580_04	6000	5735	270	770	200	1351	48°	270			
M11_02580_04	6150	5885	270	920	200	1351	46°	270			
M11_02580_04	6300	6035	270	920	200	1351	46°	270			
M11_02580_04	6450	6185	270	920	200	1351	45°	270			
M11_02580_04	6600	6335	270	920	200	1501	45°	270			

Hauteurs/Height

REFERENCE	Long./length Eqipt.	Pose- Dépose/Load- Unload	Bennage / Tipping	Ordre de route/under cradle	Benne basculée/contai- ner tipping	Décrochage / Unhooking				
		H1	H2	h	H3	H4	E			
M11_02580_04	4750	2857	4912	240	-929	-161	365			
M11_02580_04	4900	2857	4954	240	-923	-161	365			
M11_02580_04	5100	2978	5024	240	-880	-77	365			
M11_02580_04	5300	2978	5173	240	-880	-77	365			
M11_02580_04	5500	3101	5424	240	-927	1	365			
M11_02580_04	5650	3101	5450	240	-925	1	365			
M11_02580_04	5850	3101	5600	240	-925	1	365			
M11_02580_04	6000	3227	5712	240	-813	84	365			
M11_02580_04	6150	3227	5724	240	-814	84	365			
M11_02580_04	6300	3356	5832	240	-851	167	365			
M11_02580_04	6450	3356	5837	240	-851	167	365			
M11_02580_04	6600	3356	5922	240	-857	167	365			

Equipement sur véhicule/Equipment on vehicle

REFERENCE	Long./length Eqipt.	Charge nominale / rated load	Véhicule / Vehicle	Charge maxi Essieu Ar./Rear axle max load	CdG équipement/CdG equipment	Poids équipement / equipment weight			
	L.	P	PTC / GVW		Yc	(Kg)	B max		
	4750	20 T	26T	19T à 21 T	2475	2200	170		
	4900				2550	2200	180		
	5100				2650	2250	200		
	5300				2750	2250	200		
	5500				2850	2350	180		
	5650				2925	2350	190		
	5850				3025	2400	190		
	6000				3100	2450	190		
	6150				3175	2450	210		
	6300				3250	2500	210		
	6450				3325	2500	220		
	6600				3400	2500	220		

Nota : Caractéristiques données à titre indicatif. Document non contractuel. En fonction de l'évolution technique de ses produits, la S.A. GUIMA se réserve le droit de modifier les caractéristiques ci-dessus sans préavis.

Note : Specifications are only given for guidance. This document is not contractual. According to technical development of its products, GUIMA reserves the right for itself to change the above specifications without previous notice.

FMX 400 HP 6*4 Rigid		
FO Number / OM Number		Print date
VSS-20-702202 /		2020-02-21
Firm planning date / Last Change Date	VIN Number	
/ 0 (YYYYWWD)		
Build week (YYWW)	Confirmed delivery day	Planned arrival date
202017	(YYYYWWD)	
Latest update		

Chassis Unique Homologation Document	General Homologation Document
LEGCHECK	

BEP, chassis unique drawing in scale

General chassis drawing:

- [FM64R3CTX_2011.dxf.zip](#)
 - [FM64R3CTX_2011.pdf](#)
- Data Sheet :** [fm64r3ctx_global_engvt.pdf](#)

Supplementary drawing(s):

- POWER TAKE-OFF
[22885846_01.dxf.zip](#) [22885846_01.pdf](#)
- BODY ATTACHMENT
[3200308_03.dxf.zip](#) [3200308_03.pdf](#)
- EXHAUST SYSTEM
[3200318.dxf](#) [3200318.pdf](#)
- SPAREWHEEL CARRIER
[3200345.dxf.zip](#) [3200345.pdf](#)
- CAB-DAY
[3200351\[1\].zip](#) [3200351.pdf](#)
- FRONT MOUNTED EQUIPMENT. RADAR ZONE.
[FMX_Front Radar Keep-out-zone.zip](#) [FMX_Front Radar Keep-out-zone.JPG](#)

Tyres front	Tyres rear
315/80R22.5 BRIDGESTONE M840 EVO	315/80R22.5 BRIDGESTONE L355 EVO

 Latest updates

Technical Specification

ADMINISTRATION	
Variant	Description
URH	Without roof hatch
UL-FUEL	Without left diesel tank
R415S56	Right 415 litre steel 560 mm high D-shaped diesel tank
MIRSTDX	EI heated robust main rear view mirrors and wide angle mirr (both sides). Close view mirr pass side.
UDRIVE	Without driving package
UTACHO	Without tachograph
8WA-MSP	West Africa
SS19W51	Pricelist Period 19W51-20W10
BC-FMX13	FMX13 model for Business Control
FMX1364R	FM 64 R ENG-VE13
UASAFE	Without active safety package
FMX64R40	FMX 400 HP 6*4 Rigid
XHIGTR	X-high chassis height with T-ride
ULSA	Without local sourcing
USWUR	Remote software upgrade disabled
UDFFAM	Without Fuel Advice
UDRUT	Without My Truck app
URESERM	Without remote service message
TC-CONST	Construction transport cycle (driving pattern)
UDFVH	Without dynafleet vehicle status service
MFACTBEL	Main Factory Belgium
UPVTS	Without preview topography service
UBODYPK	Without Body Builder preparation package
EU3	Euro 3 engine emission level
UDFFUEL	Without Dynafleet Fuel & Environmental service
UDFDTM	Without Dynafleet Driver Times service
UDFPOS	Without Dynafleet Positioning service
UDFMSG	Without Dynafleet Messaging service
8AF	Market area Africa
WB4300	Wheelbase 4300 mm
CLASHDV	Classic Heavy Duty Vehicle, Volvo
24-HDV	New generation Volvo heavy vehicle
FM 64 R	FM 6x4 Rigid
DIRT-HIG	Much dirty roads/surfaces

UEGR	Without exhaust gas recirculation
TYPE-FM	FM Low tilt cab
UWVTAPPR	Without Whole Vehicle Type Approval, EC
6*4	6x4 - Three axles, two axles driving
RIGID	Rigid model
RC-ROUGH	Rough road conditions
GCW70.0	Gross combination weight 70.0 tonnes
ENG-VE13	12.8 litre six cylinder engine
VH4.5	Total vehicle height max. 4.5 metres
RAL32	Rear axles load 32 tonnes
STWPOS-L	Left hand drive
VW2550	Vehicle width 2550 mm
FAL9.0	Front axle load 9.0 tonnes
UADR	Without ADR adaptation (transportation of dangerous goods)
MA-BAS	Basic market adaptation
CHH-XHIG	Chassis height extra high - approx. 1030 mm above ground level
UCONSAFE	Connected safety disabled
ALTI2500	Altitudes up to 2500 metres above the sea level
J1E-AAX	PROCESS A FOR CLASSIC 24-HDV
COG-BAS	Complete superstructure & payload centre of gravity between 0.5 m and 1.0 m above top of truck frame
CURV-L	Low curve density (the speed is seldom reduced due to driving in curves)
UVUPT	Vehicle uptime settings disabled
NR-BASIC	Without exterior noise requirement
UCONBOS	Without subscription connected bodies
DTECH-CO	Combustion driveline technology
EFC-LQ	liquid fuel
UADRC	Without ADR classification
ULEGC	Legislation check disabled for order
B-HOOKL	Hook lift
ULHE1	Without tail lift
ULHE2	Without crane
ULHE3	Without snow plough
ULHE4	Without miscellaneous load handling equipment
T-PFLAT	Predominantly flat topography
UVASSIST	Vehicle assistance service disabled
RFUEL	FICTIOUS VARIANT RIGHTHAND FUELTANK (ALL SIZES)
UWVTA	Not Whole Vehicle Type Approved
RT-STEEL	Steel rims on all axles
F315-80A	Front axle tubeless tyre 315/80R22.5
D315-80A	Drive axle tubeless tyre 315/80R22.5
UPHTRI11	Seat with grey text ins&vinyl bolster, red vinyl side ins&vinyl/text inter trim in skylark/grey/blac
UOFFROAP	Without construction package
UMBAC	Without market business package
ESH-LEFT	Horizontal muffler, left exhaust outlet
FMX-DAY	FMX Day cab
URESTING	Without living package
AUBAS	Audio basic. RDS radio/CD, FM/AM ant & dash/door speakers. Prep for Dynafleet office portal support.

ENGINE WITH MOUNTING AND EQUIPMENT

Variant	Description
UADTP	Without AdBlue tank position
UTFUEL	Without temporary diesel tank
UOBDEC	Without high emission level consequences
UOBDEP	Without OBD emission phase regulations
PRIM-MAN	Manual priming pump for fast and easy bleeding of the fuel system
FTCL-BAS	Fuel tank with basic ground clearance
UWILDBAR	Without wild bar
UFTI	Without fuel tanks interconnection
OILS-ST	Steel oil sump
TURB-HD	Turbo heavy duty design
HS-BAS	Basic muffler heat shield for all emission variants
CCV-O	Open crankcase ventilation
UADB	Without AdBlue tank volume
FUEFE2LW	Large engine mounted dual fuel filter with water separator and drain. For poor fuel (outside WestEu)
XFUEL50	Extra fuel filling 50 litres
ATL15	Ambient temperature down to -15 degrees C
UISD	Without idle shutdown time

ATU-VH	Ambient temperature above +40C
UFUFF	Basic fuel filling
UFUEQWH	Without fuel line heater
DIESEL	Diesel fuel
TURBO-S	Turbo single stage
UETEC	Without engine temperature control - Extreme conditions
<u>BUGNET</u>	<u>Radiator screen / Mosquito net (PVC coated fibreglass) in front of radiator</u>
<u>D13A400</u>	<u>Diesel engine, 12.8 litre Euro 3, 400 hp, 2000 Nm</u>
ETOR2040	Engine torque range 1981 - 2040 Nm
<u>EBR-VEB</u>	<u>Volvo Engine Brake, VEB (compression brake with exhaust pressure governor, EPG)</u>
EAP-LHD2	Light heavy duty engine application (std pistons and corrosion resistant valve seats)
RFN-B	Filler neck rear of the fuel tank
UAUXFUEL	Without heated fuel filter
USPEEDDU	Without dual speed limiter
SPEED90	Road speed limiter setting 90 km/h, EC
<u>CRUISEC</u>	<u>Basic cruise control with controls in steering wheel</u>
FAN-VICE	El. temperature controlled cooling fan
<u>AIRIN-HI</u>	<u>High air intake</u>
ULGAS	Without left side gas tank
A-FREE25	40/60 mix coolant and water (- 25 Celcius)
FUELTS56	D-shaped 560 mm diam fuel tank
TNK-SING	Single mounted fuel tank
FTANK-ST	Steel fuel tank
<u>FCAP-L</u>	<u>Lockable diesel and AdBlue tank caps</u>
STRAP-P	Painted fuel tank straps
UEXST	<u>Without vertical exhaust</u>
UEXSH	Without extra exhaust heat shield
UEAS	Without exhaust particulate filter
EM-EC01	Emission level Euro 3
<u>ACL1ST-S</u>	<u>Air cleaner with additional filter element</u>
UDPFREGC	Without diesel particulate filter regeneration controls
URSPED	Without remote speed limiter
ULICPLH	Without license plate holder
UCSPEED	Without customer reduced road speed limiter
USPLIMS	Without speed limiter sensor
USCRS	Without SCR system equipment
UFUELB	Without fuel blend
UPADB	Without percentage of AdBlue filling in tank
ULFFUEL	<u>Without diesel plastic fuel tank</u>
CPSR-FIX	Fixed coolant pump speed ratio
EASO-H	Horizontal orientation of the aftertreatment system
UADTC	Without AdBlue tank cover

ELECTRIC POWER SUPPLY, LIGHTING, INSTRUMENTS

Variant	Description
UHWSS	<u>Without headway support system</u>
UARLIG	Without additional rear lights
URSENSW	Without wiper rain sensor
UTAS	Without tachograph
<u>INLI-BAS</u>	<u>Interior white light with smooth light transition at on/off, no dimming</u>
URESTS	Without reflecting white stripes on chassis side
ACCLF-D	<u>Volvo torque assist - Disabled</u>
UALCOLOC	Without alcolock
24V	Electrical system 24V
UDAS	Without Driver Alert Support (without drowsy driver warning)
UPHONE	Without telephone or telephone preparation kit
HL-ASYMR	Headlamp alignment set for right hand traffic
DETECT-S	Smoke detector in cab
HORN-ELS	Single electrical front horn
<u>HORN-F1S</u>	<u>One front mounted (behind grille) single tone air horn, Jericho. Operated by steering wheel buttons.</u>
URTOLL	Without road toll equipment
UCONBO	Without connected bodies
USOUTLET	Without electrical outlet in sleeper compartment
UFMS	Without fleet management system gateway
TWEETER	Tweeter
<u>ECBB-HIG</u>	<u>Body builder electrical centre with cab body builder module</u>
SIDT-B	Basic type of secondary information display

POSMLP-W	Two white front roof mounted position lamps (end outline marker lamps, LED on FH)
AUDS-A	Audio signal - AM/FM
UASL	Without spot lamps in sign box
WWF-ALC	Windscreen washer fluid with alcohol additive
UWLAMP	Without working lamp
BEACON-P	Prepared wiring (switch and connected relay included) for warning lamps on cab roof
SPG-KM	Speedometer scale kilometres per hour
UESTAID	Without pre-heating element
TL-LED	LED tail lamps
MSWI-C	Chassis main switch - battery box placed toggle switch circuit shut down
UFOGLAMP	Without front fog lamps
UDRIVL	Without auxiliary front driving lamps
UAUXL	Without snow plough preparation kit
UHLADJ	Without headlamp adjustment
UHLCLEAN	Without headlamp cleaner
UIMMOBIL	Without immobiliser
UIDLAMP	Without identification lamps
MARKL-SR	Side and rear marker lights
USRL	Without chassis working lamps
DIFL-FRA	Driver information first optional language - French
UDISL	Default second optional language, English
SAS-INFO	Service alert system
HL-BAS2	Halogen H1 head lamps (heavy duty)
24AL110B	Alternator 110 Ampere
SI-SPEED	Speedometer instrument, odometer
UTGRAPH	Without tachograph
CALI-BAS	Basic calibration of tacho. & speedometer
UNAVS	Without navigation system
BATTD128	Battery density, 1.28 acid solution
UASSIST	Without assistance
USPOTP	Without spotlamp preparation
USINF	Without service and infotainment
BATS-S	Single energy battery storage system (2 batteries)
ULOADIND	Without load indicator
UTAMA	Without tachograph market area preparation kit
UALARMB	Without burglar alarm
UAUXSW	Without wiring for extra switches
INST-MED	Medium level instrument cluster - 4 inch colour display 240x320 pix
AUD-CDB	Radio with CD player
BATTAMP	Battery voltage and ampere gauge
UEXSTER	Without support for external steering control via body builder module
DRL-LED	V-shaped ("V-light") day running light (LED)
SID-BAS	Dashboard integrated monochrome information display, 75 x 735 pixels / 150(W) x 30(H) mm
EWT5000	Equivalent wheelbase turning, 5000 mm
BLIGHT-B	Basic brake light
UBATTREC	Without battery reconditioner
URPLCR	Without rear position lamp
BBOX-L	Battery box on left hand side
2BATT170	Batteries 2x170 Ah
UAMPL	Without external amplifier
UCLSTAT	Without cornering lights
BAMAFREE	Enhanced flooded batteries extra
UBEPREP	Without body builder software electrical preparation
UWLC	Without working lamps back of cab
TD-BAS	Trailer detection without LED sensor
UAHS	Without automatic headlamp switching
BBCHAS3	Three 7-pole connectors for Body builder interface
TLB-BAS	Basic tail light brackets
UANTCB	Without antenna for CB radio (no antenna attachment)
SPK-DADO	Loudspeakers in dash & doors
UAIP	Without audio integrated handsfree phone
UACON	Without USB audio communication connector
UXCON	Without audio AUX Line in connector
UAESW	Without Body builder electrical switches
TGW-PK	Telematics gateway preparation kit
HLP-ST2	Steel wire mesh headlamp protection

UREMCON	Without wireless remote control
BUPALARM	Back-up alarm
UARL	Without flexible reading lamps
UINFOT	Without TV mounting preparation kit
UBUPMON	Without back-up monitor
UDRID	Without telematics driver ID with USB
ULSS	Without lane keeping support
ULCS	Without Lane Change Support
UARSL	Without additional road speed limit
AUDWB1	Audio wavebands FM 87,5-108,0 MHZ, AM 522-1611 KHZ
UMAPR	Without map region for navigation
UBULBKIT	Without bulb and fuse kit
ULAMPIN	Without inspection lamp

POWER TRANSMISSION

Variant	Description
GSS-AGS	I-shift lever gear selector
URSO	Without extra reverse gears
UPTER	Without rear engine mounted PTO
TC-MAOH2	Extra high performance cooler for manual/I-shift gearboxes - air/oil
UPTOENGR	Without rear engine mounted PTO
PTR-DH	Mech. gearbox driven high speed PTO, 1 rear conn. (DIN 5462/ISO 7653 for plug-in pump (max. 600 Nm)
RAT4.12	Rear axle ratio 4.12
PROPS-LE	Prop. Shaft Large - Extended 180 mm diameter
PSM1	Propeller shaft manufacturer Dana Spicer
DL-FULL	Differential lock between axles and wheels
UPVT	Without topography information
UEPTT	Without engine power take-off torque capacity
TRAP-BAS	Basic gearbox application
HRED-V	Hub reduction rear axle
RTH3210F	Rear hub reduction tandem axles - bogie load 32 tonnes. GCW 100 tonnes. version F
CS43B-O	Single plate clutch, plate diameter 430 mm
TRA-AMT	Automated mechanical gearbox
AVO-ENH	Enhanced I-shift software for construction and off road applications
TP-CON	I-shift construction gear changing software
APF-BAS	Basic I-shift PTO functions
UASO	Without crawler gears
TPTT600	Gearbox power take-off torque capacity 600 Nm
TTOR-B	Basic transmission output torque
AMSO-AUT	I-shift manual gear shift available in automatic mode incl kickdown function
AT2612F	I-Shift automated mechanical 12-speed gearbox without clutch pedal, 2600 Nm, GCW 100000 kg

BRAKE

Variant	Description
ATANK-ST	Steel air tanks
UESPFC	Without ESP (Electronic Stability Program) functionality control
FBRA175	Front axle brake lining 175 mm
UTBRD	Without tag axle brake
RBRA200	Drive axle brake lining 200 mm
UTBRA	Without tag axle brake dimension
BSYS-EBS	Electronic brake system
DBRDUST	Dust shield for rear brakes
UAUXPARK	Without extra parking brake
BRAKE-ZV	Volvo Z-cam brakes
FBREG-E	Front axle regulating brake valve for EBS
URETARD	Without retarder
UAUXATNK	Without extra air tank
2COMP900	Dual cylinder air compressor 636 cc
TRBRAKE	Trailer brake valve
UTCP	Without trailer connection bracket position
TRBR-STA	Stationary trailer brake control
ABS	Lock free brakes
UESP	Without Electronic Stability Program package
UTRACON	Without trailer light converter
UTABS	Without trailer ABS circuit converter
UPBRAD	Without pusher axle disc brake dimension
UCLUAIRC	Without clutchable air compressor
PBREL-A	Automatic parking brake release

UTECABLE	Without electric cable for trailer brake
UTBCONN	Without trailer brake connection
TREL7-7	2x7 pol (24N+24S) electrical trailer connectors (UADR)
PNPROT	Protective cover for chassis mounted pneumatic equipment
UTBHOSE	Without trailer brake connections
EBS-MED	EBS (Electronic Brake System) medium package
UTRBSTRE	Without low speed automatic trailer brake activation (stretch brake)
PDC-OFF	Pneumatic distribution center location - outside frame, front
BF-DRCAS	Drum brakes

WHEEL SUSPENSION AND STEERING

Variant	Description
UTAAXLIF	Without tandem axle lift
UASFE	Without Volvo Dynamic Steering
PSS-SING	Single power steering system
STGW-ADJ	Mechanically adjustable steering wheel
ULDFA	Without load distribution on front axles
URALIM	Without first rear drive axle load limiter
ULIFT	Without bogie lift
UAUXPSP	Without extra power steering pump
URVCERT	Without vehicle certification, road
UBCYLPRO	Without brake cylinder protection
RADD-TR2	Rear leaf suspension, 2 axles - 2 driven (Max. technical boogie load 32 tonnes)
FA-XHIGH	Front axle extra high ground clearance
FAA10	One front axle, not driven
URSTS	Without rear steering system
UACTST	Without active steering
BL-EQL	Equal bogie load sharing across all axles
PSP-FIX	Power steering pump with fixed displacement
STW-D450	Steering wheel with diameter 450 mm
U1PAC	Without first pusher axle capacity
U1TAC	Without first tag axle capacity
STWM-BAS	Standard steering wheel material
STG20.0	Steering gear ratio 20.0

FRAME, SPRINGS, DAMPING AND WHEELS

Variant	Description
WTDF22.5	Front wheel and tyre inner diameter 22.5 inches
WTDD22.5	Drive wheel and tyre inner diameter 22.5 inches
UWTDT	Without tag axle wheel and tyre inner diameter
UTWT	Without tag axle wheel type
UWTTM	Without tag axle wheel and tyre mounting
WMF-ST	Front steel rims
WMD-ST	Drive steel rims
UWMT	Without tag axle rim material
WDF900	9.00 inch front axle rims
WDD900	9.00 inch drive axle rims
UWDT	Without tag axle wheel dimension
INFLAHOS	Tyre inflation hose (18 metres) with nozzles in both ends
UTIREPM	Without tyre pressure monitoring
UTT	Without tag axle tyre
TMF-BRID	Bridgestone front axle tyre
TMD-BRID	Bridgestone drive axle tyre
UTMT	Without tag axle tyre
TR-AFR2	Tyre region Central Africa
UFSLs	Without air suspension levelling stroke
UASF	Without air suspension driving level feature
GUARD-EH	Guard plate for cooling pipes and oil sump
SWCP-LF	Spare wheel carrier on left side in front of rear axle
SPWT-F	Spare wheel with tyre equal to front wheel
FSI-LEAF	Front leaf suspension
UGAUGETP	Without tyre pressure gauge
UARSTA	Without additional rear stabilizer
URUPP	Without rear underrun protection pos.
WTA-TL	tubeless tyres
WSTUD-S	Short wheel studs (alu dual hol)
UTMPR	Without pusher axle tyre
URSLS	Without rear air suspension levelling stroke (for leaf suspension)

XMBRR-B	Basic rear crossmember closing
UMRUP	Without rear underrun protection
<u>FSM-LUB</u>	<u>Lubricated front suspension pins and bushings</u>
UWCAP	Without wheel caps
USUPS	Without steps in side underrun protection
UTRTT	Without tag axle tyre tread
UPTT	Without pusher axle tyre tread
UFUP	Without front underrun protection
UWTDP	Without wheel and tyre diameter on pusher axle
UFRF	Without frame rail clearance
RSAP-BAS	Standard rear suspension application (without reinforcements)
UFALIM	Without front axle load limiter
PROTC-I	Improved corrosion protection level
UTWP	Without pusher axle wheel type
UWDP	Without pusher axle wheel dimension
URESTRUP	Without reflecting red stripes on rear underrun protection
UFRACLOS	Without frame end closing
TXMB4827	Transmission crossmember web location (main 4827)
<u>RFEC-S</u>	<u>Rear frame end, straight cut (for regular platform applications)</u>
XMBT-S	Strong transmission crossmember
FST8080	<u>Frame section thickness - web 8.0 mm / flange 8.0 mm</u>
FRAME300	Frame rail section external height 300 mm
<u>RFL2195</u>	<u>Rear frame length 2195 mm from 1st drive axle</u>
URUP	Without rear underrun protection
<u>FST-PAR3</u>	<u>3 leaf front parabolic suspension (stiffer than normal)</u>
RST-MUL	Rear conventional multi-leaf suspension
FSS-LEAF	Front leaf suspension
RSS-LEAF	Rear leaf suspension
FSTAB2	Front stabilizer with medium high stiffness
USUP	Without side underrun protection
RSTAB1	Rear stabilizer with normal stiffness
<u>FIL-TXEB</u>	<u>Frame inner liner from transmission cross member to end of bogie</u>
USUSPLEV	Without suspension levelling

BODY, CAB AND INTERIOR

Variant	Description
UEBHEAT	Without electrical engine block heater
FMUDE-B	Front mudguard extension, basic
UCSPL	<u>Without storage in lower center dash panel</u>
UARMRU	Without armrest upholstery
GRABHI-B	Steel instep grab handle
UCPR	Without cab roof protection
UCLEQ	Without extendable windscreen cleaner
UBUMPSP	Without front bumper spoiler
UTBL	Without left toolbox
UTBR	Without right toolbox
USBPREDS	Without driver seat belt pretensioner
<u>JACK-20T</u>	<u>Jack 20 tonnes</u>
<u>TOOLKIT</u>	<u>Extended tool kit</u>
RUSTP-T	Full transport rust protection, 3000 ml wax
UEMBO	Without emblem options
DGLAS-H	Tempered door glass
UCOFMAK	Without coffee maker
USTUC	<u>Without storage compartment under cab</u>
UWRNLAMP	Without portable warning lamp
USBPREPS	Without passenger seat belt pretensioner
UGLASC	Without glass coating on side windows
<u>1103WHIT</u>	<u>Cab colour solid Winter White (NCS 1202-Y03R) / Solid clear coat = 7103WHIT</u>
<u>PAICS-B</u>	<u>Basic painting in a lightning grey colour of mirror housings, insteps and bumper</u>
UWLOCK	Without window control lock
ULADDER	Without ladder back of cab
UKEYF	Without radio communication channel
EMBL-MO	Mounted emblems
UBOTTLEH	<u>Without bottle holder</u>
UMICROWV	Without microwave equipment
SUPH-VT	<u>Seat upholstery - black embossed textile insert, black vinyl bolster and red vinyl side insert</u>
UTABLE	Without foldable table

CABPT-R1	One front cab roof pass through on passenger side
UWARVEST	Without warning vest
UAIRBAG	Without airbag
URUS	Without rear cab upper storage
UOLMAT	Without overlay mattress protector
UWRITEP	Without writing pad
USIGNS	Without green and safe signs in front
URLS	Without storage under bunk
UVANMIR	Without vanity mirror
UMATTRES	Without lower mattress
DLAY-BAS	Basic dashboard layout
DTRI-RAV	Dashboard in black/raven
TOP4	Transmission oil STD 1273,15. Thick synthetic oil. Needs filtering and cleaned transmission.
UCFAFS	Without foldable extra front cab foot-step
HCC-EXT	Unlockable front lid - Exterior hood catch control
SBD-BAS	Black safety belts, passenger and driver seats
SBP-BAS	Black safety belt, passenger seat
UADH	Without roof aerodynamic device height
UCPARKC	Without cab parking cooler
UADCF	Without additional flap on chassis fairings
UAIDKIT	Without first aid kit
ISUNF-B	Interior front plastic sun visors (driver and passenger side) without mirror on driver side
UAUXFS	Without extra cab side foot-step
USIMC	Without sim card
CSPT-T	Center section dashpanel top, tray
PUBS-FRA	Driver's handbook in both local language and French
EXTL-BAS	Basic exterior finish in a lightning grey colour of mirror housings, insteps and bumper.
UTBUNK	Without top bunk
UIDLMPSW	Without switch for identification lamps
CSPU-S	One open storage (behind push open lid) in upper part of dash panel center section
UAWINDR	Without rear window
UROHO	FH: Non opening sky window (tinted glass)/emergency exit (with emerg hammer). FM: Without roof hatch
UCABSIGN	No cab sign decal. FH,UCABSIGN,ROS-IL/ROS-ILP=white area. FH,UCABSIGN,UROSIL=black. FM=white area.
UEMIEMBL	Without emission emblems
CAB-DAY	Day cab
RCABS-M	Mechanical rear cab suspension
CTILTP-M	Manual cab tilt pump
UADFS	Without extra DIN slots in front shelf (blind slots)
FMUD-AS	Mudflaps with anti-spray on all front axle fenders
USIDESTP	Without side foot-step and handle
FCABS-M	Mechanical cab suspension
UAWINDS	Without rear side window
WLIFT-ME	Mechanical window lift on both sides
URHATCH	Without roof hatch
GLAS-TIN	Tinted windows (front/side/rear)
ULBK	Without lower bunk
FMAT-RU2	Two black rubber floor mats with raised edges and an extended side (FMX)
PST-BAS1	Passenger seat, basic, non suspended
CABH165	Cab height 165 cm
UACCBKRT	Without roof mounted accessory bracket
UREFS	Without reflecting stripes on cab
LANG-EF	English/French text on decals/signs
PUBL-GBR	English publication language
UCERTLAB	Without certification labels
LOCK-MAN	Manual door locking
UREFL	Without reflectors
DPAN-B2	Door panel in red vinyl (electric window lift) or black (raven) plastic (mechanical window lift)
UMATINS	Without insert mat on engine tunnel
AMIR-WB	Wide angle mirror on both sides
AMIR-F20	Front close view mirror above windscreen, passenger side (radius 200 mm)
TRIM-RB	Vinyl interior trim in matching grey nuances
UARMREST	Without armrests on driver and passenger seats
UROSIL	Without illuminated roof sign
DST-CF1	Driver seat, comf, susp
FIREXT3S	Fire extinguisher 3 kg, Swedish/English decal
UPARKH	Without parking heater

AMIR-S30	Close view mirror on passenger side, radius 300 mm
ISUNS-DS	<u>Manually manoeuvred side interior sun visor (roller blind type) on driver side</u>
UAS	Without extra shelves in front rollfront compartments
CU-MCC	<u>Electrical manually controlled air conditioning</u>
UACU	Without additional climate unit
UDFHFP	<u>Without Dynafleet Positioning+ service</u>
BUMP-HD	<u>Heavy duty front bumper</u>
TOWF-HD1	<u>One heavy duty front towing device</u>
UWINREP	Without cab side window replica
UBEDNET	Without net for lower bunk
USAFETYB	Without safety box
MPLA-ENG	Manufacturing plate, English version
USLCP	<u>Without sleeper control panel</u>
SUNV-H	<u>Exterior transparent dark grey front sun visor</u>
UXSEACAB	Without extra cab sealant material for dust tightness
UADROOF	Without roof air deflector
UADSIDE	<u>Without cab side air deflectors</u>
UADCHAS	Without chassis side skirts
UWARNTRI	Without warning triangles
UMIRRTXT	Without mirror text
UETSBOX	Without engine tunnel storage
UREFRIG	Without refrigerator
USIGN	Without front cab sign
XINS-CAB	<u>One extra layer of cab insulation</u>
UGUARDW	Without windscreen stone guard

Miscellaneous

Variant	Description
UFFEND	<u>Without fenders on second front axle</u>
COD-CIV	Destination country Ivory Coast, national frequencies
CG-AF1	Destination country group Africa 1, national frequencies
URFCAR	Without rear fender carrier
URMUDF	Without rear axle mudflaps
URFENDER	Without rear fenders
UFWPOS	<u>Without fifth wheel position</u>
U5WMOUNT	<u>Without fifth wheel mounting</u>
U5WHEIG	<u>Without fifth wheel leg-height</u>
UKPSIZE	Without king pin size
U5WTYPE	<u>Without fifth wheel</u>
URAMP	<u>Without sliding members/protection members</u>
UTOWTYPE	Without towing member
UTOWMBR	Without towing member
UCOUPLIN	Without towing coupling
TOWR-ONE	<u>One rear towing device in frame end cross member</u>
UWHCHOCK	<u>Without wheel chocks</u>
URDECK	Without rear deck
UTAIL	<u>Without tail lift preparation</u>
UHPG	Without gearbox mounted hydraulic pump
UFFTP	Without second front axle fender top height
TIPP-PRE	Tipper vehicle preparation
ULCHF	Without load carrier
ULCL	Without load carrier length
RFC-2	Fender & front underrun calc. exempted from EC front underrun and anti-spray requirem (NG3 off-road)
RFH-BAS	<u>Optimal fender installation (rear and 2nd front axle)</u>
U5WLM	<u>Without fifth wheel maintenance</u>
FACT-BEL	Final assembly plant Belgium
7800MM	Frame length 7800 mm
UCHAGH	Without chassis grab handles
UCHAINS	Without snow chains
UTMP	Without towing member position
UFFQP	Without second front axle quarter fender mounting position
UCROSSRE	Without cross reinforcement for swapbody
U5WLUB	<u>Without fifth wheel lubrication</u>
UTCIND	Without trailer connection indication
HBA-FSFB	<u>Holes for body attachments, flexible/semi-flexible body</u>
UHOOKSC	Without snow chain hooks
UPSCAT	Without propeller shaft catcher

UCRANEPK	Without crane plates
SDC-BAS	Steering demand calculation according to internal requirements
FBA-BTSF	Lower front body attachments for torsionally semi-flexible body (van or curtainsider)
RBA-T2	Lower rear body attachments for helper frame
UHPE	Without engine mounted hydraulic pump
UWHCP	Without wheel chock position

List of warnings/errors (0 message):

No restrictions violated

Application version: 155, EDB library version: 342.0.0 Elapsed: 2.90 seconds Built: Sep 24 2019, 14:25:49

