

## 2023 FHS 55 4WP

STOCK NUMBER: IN STOCK

NEW

IMMEDIATE DELIVERY

MAST HEIGHT 10 OR 12 FT



### OFFER INFORMATION

Location details

2324 Palmer Dr, Schaumburg, IL, 60173 - United

States

Dealer Name



Product type

New

Stock number

In Stock

Contact person

Jason Gaydos

Dealer E-mail

[j.gaydos@palfinger.com](mailto:j.gaydos@palfinger.com)

Dealer phone

[1-484-225-2607](tel:1-484-225-2607)

## FHS 55 4WP STANDARD FEATURES

- Multi-directional travel  
Forward>Reverse>Left>Right with long loads through narrow openings.
- Patented Low Profile Reach System with integrated side shift and additional tilt.
- 25° Outward Swivel Seat allows easier entrance and exit from the cab and minimizes seat edge wear.
- Industry Leading Operator Floor Space & Cabin Area is maximized with all trip hazards removed.
- Patented Integrated Side Operator Guard ensures permanent protection and eliminates misuse.
- Double Lift Cylinders behind mast rails maximize visibility through the mast.
- Class 4 fork Carriage Opening maximizes fork tip visibility at all critical operation heights.
- The low-profile engine hood maximizes visibility to the right side of the machine.
- All-wheel braking provides increased safety and stopping power.
- 46" High Fuel Fill Driver Side position enables safe/low ground-level refueling even when mounted on the transport truck or trailer.
- The pump-mounted Diff-Lock Valve eliminates additional unnecessary hoses, provides a better layout, and ensures easy diagnostic and hose maintenance.
- Oversize 1" Dacrotized Lift Chains ensure a long lifetime while increasing visibility.
- Oversized 4" Mast Carriage Channels and Bearings give trouble-free operation and added strength without problematic wear pads.

## OPTIONS

- Load Back Rest
- Seat Cover
- Rear View Mirror
- Rear Tires
  - Skid Steer
- Forks
  - Lumber
  - Pallet

# **PALFINGER FHS 55 TRUCK-MOUNTED FORKLIFT**



“

*If I have a voice in this, I'd rather have a PALFINGER on the back of my truck instead of the competition."*



# PALFINGER TRUCK-MOUNTED FORKLIFTS - FHS 55 SERIES



We didn't design our forklift with you in mind – we created it with you by our side. The reinvented FHS Series forklift wasn't born in a conference room or as an engineering doodle. Instead, it all started with YOU:

- **The Fleet Managers** – who want a stronger, safer, more comfortable and powerful forklift with incredible visibility and maneuverability to efficiently deliver products on and around your customers' job sites
- **The Company** – that needs to deliver masonry products through soft sugar sands or up steep hills with ease
- **The Operator** – who must navigate over spotless driveways, manicured lawns and confined backyards to deliver building materials

The result is a product with new features, innovations, and patents that permits us to say we have truly reinvented the truck-mounted forklift. The new FHS Series forklift combines the highest level of convenience with a very appealing design and purposeful technologies. We stand by our product and back it up with our national service network, which will keep you on the road, working day after day.

WE MADE IT STRONGER. WE MADE IT SIMPLER.  
WE MADE IT SAFER. WE MADE IT BETTER.  
WE MADE IT PALFINGER.

# STYLE & DESIGN

## THE ALL-NEW PALFINGER FHS SERIES LOOKS NOTHING LIKE ANY OTHER TRUCK-MOUNTED FORKLIFT

The exterior has a striking look with its higher ground clearance, lower profile engine hood, powder-coated chassis, and contemporary angular styling.

Inside, there's increased legroom and a spacious operator cabin. In addition, **our patented swivel seat assembly with 25° outward rotation** increases access when entering and exiting the machine. Finally, there is an **integrated side guard** providing extra protection for the operator.

When seated, the panoramic visibility is like nothing you have seen before. The driver always has the best view of the fork tips and the entire working area.

### SIDE VIEW (LEFT)

- A** Contemporary angular styling with 45° corners offers a sleek look that matches today's commercial vehicles
- B** Standard side mount operator controls eliminate the need to climb on/off the machine during the mounting/dismounting process
- C** Integrated side guard with automatic closing functionality
- D** 3-Point entry and exit with ergonomically arranged steps and grab handles for ease of entry and exit
- E** Ground level diesel fuel fill for easy refueling when the forklift is on the ground or mounted on a truck or trailer





# STYLE & DESIGN



## SIDE VIEW (RIGHT)

- A** Spacious ergonomic operator cabin with ergonomically arranged foot pedals, digital display and easy-reach control levers and switches with armrest
- B** Radiator panel and robust molded bumpers on rear corners
- C** Main frame side pods provide additional structural rigidity and a clean overall look



## FRONT VIEW

- A** Low profile engine hood significantly increases right-hand side visibility
- B** LED work lights
- C** Front DOT compliant street lighting kit
- D** Class IV carriage opening for increased visibility



## REAR VIEW

- A** Main frame design with 45° rear corners minimize turning radius and extend beyond the inset body panels, protecting them from impact
- B** ROPS and FOPS tested and approved overhead guard
- C** Strobe light
- D** Folding SMV sign
- E** Rear DOT compliant street lighting kit
- F** 180° Rear steering for maximum maneuverability
- G** 5° Inward seat positioning increases rear view visibility



## MAIN FRAME CHANNELS

The sturdy main frame uses Standard 4 channel section, which enables the use of larger diameter and wider mast carriage rollers that greatly reduce loading and wear.



## CARRIAGE CYLINDERS

Carriage cylinders are recessed below the mast carriage, providing a lower center of gravity for the machine and added protection from damage caused by falling debris.

## CORROSION RESISTANCE AND GUARDING

- Composite body panels
- KTL-treated and powder-painted chassis
- Galvanized steps, stabilizers, wheel motor guards, transport chain hanger brackets
- Dacrotized mast chains
- Zinc-coated mast and chain rollers
- Wheel rim valve stem guards
- Protruding wrap-around chassis

“

*I love the ability to load and unload the forklift from the ground without climbing up on the machine.”*



# SAFETY & ERGONOMICS

## EASY TO OPERATE: GROUND CONTROL

The PALFINGER Ground Control System comes standard on all models and allows operators to mount and dismount the forklift from a truck or trailer without climbing on board.

Once the forklift is started, operators use three (3) ground-level electro-hydraulic switches on the side-mounting control panel to tilt, extend and lower the machine through the dismount sequence.

By eliminating operator slip and strain hazards from climbing on and off a truck-mounted forklift, PALFINGER's Ground Control System raises the standard in Operator Safety. Operators are no longer required to overextend themselves by trying to climb up on the forklift to dismount from the truck or trailer.



Lower the forklift and go...use the three switches to TILT, EXTEND and LOWER the machine to the ground

## FROM THE GROUND...



Start the engine with the ground level ignition key



Relax the transport chains



Retract and stow the suzie cable



Unpin and stow the transport chains

# OPERATOR COMFORT & SAFETY

## SPACIOUS AND ERGONIMICALLY DESIGNED – SEEING MORE THAN EVER BEFORE

PALFINGER's panoramic visibility sets a new standard in operator visibility and safety. The fork carriage utilizes Class III fork boards with a wide Class IV opening. Lift cylinders positioned behind the mast uprights give way to an unprecedented forward field of vision. As a result, seeing the fork tips has never been easier.



### INSIDE THE CAB, YOU WILL FIND:



Digital display and easy-reach control levels with armrest



Conveniently located weather-resistant control switches



Ergonomically arranged foot pedals with ample floor space



All-weather glass overhead guard cover



Deluxe seat with high visibility orange seatbelt and integrated side guard

# SWIVEL SEAT

## 25° OUTWARD SWIVEL FOR EASE OF ENTRY AND EXIT



Our patented swivel seat assembly significantly increases access when entering and exiting the machine due to the 25° outward rotation.

## 5° INWARD SEAT POSITION FOR IMPROVED 360° VISIBILITY



The 5° inward seat position reduces body movement and neck strain when traveling in reverse, and increases the operator's rear-view field of vision.

The smart design of our integrated, automatically closing side guard always ensures an extra level of protection and safety for the operator while eliminating misuse.

# PALFINGER PERFORMANCE+ PLUS

## INCREASED POWER AND PERFORMANCE

The PALFINGER FHS 55 is highly stable, fast, rugged and exceptionally agile. It effortlessly travels over rough terrain and curbs, up hills and across all job sites. The all-wheel drive and powerful engine provide the operator with more torque and ground speed, smoother hydraulic functions and outstanding performance and handling while navigating through all types of terrain.

Additional performance features include brakes on all three wheels for added safety, along with a pump-mounted differential lock to eliminate the need for large connecting hoses.





## TIER IV COMPLIANT

The 56 PH Kohler 4-cylinder turbo diesel engine provides a reassuring 3 years/2,000 hours engine warranty\*, plus a 5 years/3,000 hours emission warranty.

*\*When following the recommended routine maintenance schedule*

# EASY ACCESS SERVICE

The quick-release, tilt-up hood and hinged rear door provide service-friendly access to all engine components and service points. In addition, the hydrostatic pump and integrated differential lock are easily accessible from the front for service and maintenance.

All PALFINGER systems are of the highest industry standards. Electrical connections are IP68-rated. Hydraulic hosing is kept to a minimum, with extensive use of steel hydraulic lines throughout to minimize leaks.

## SERVICE POINTS

### UNDER THE HOOD

- Oil filter
- Fuel filter
- Engine coolant fill
- Air cleaner & filter
- Radiator fan cowling
- Battery and isolator switch

### BEHIND THE DOOR

- Hydraulic oil filter & filler cap
- Fuses & relays

### FROM THE FRONT

- Pump mounted differential lock





## NATIONWIDE MOBILE FIELD SERVICE

PALFINGER Service is here to keep you moving. Our knowledgeable and experienced technicians service PALFINGER cranes and forklifts, plus other makes and models. As the gold standard in servicing truck-mounted lifting equipment, we're here to help you extend the life of your investment.



# EXPLORE THE PALFINGER FORKLIFT RANGE

Whichever PALFINGER truck-mounted forklift you choose from the FHS Series, you can be sure that it will always be the right choice! All models come with the exceptional safety and performance features you have come to expect from PALFINGER.



**REACH** - With the unique PALFINGER Reach System, you can offload from just one side of the truck or trailer no matter how confined the job site.



## FHS 55 STANDARD

The FHS 55 delivers a truck-mounted forklift with convincing performance and efficiency. It's strong and powerful, yet light and compact enough to easily transport on most trucks and trailers. Designed for applications requiring a lifting capacity of up to 5,500 lbs., count on the FHS 55 to handle all loads—ensuring faster and more efficient deliveries.



## FHS 55 P REACH

The FHS 55 Reach forklift is the picture of precision, efficiency and control. Our patented Reach System extends the forks forward to the centerline of the trailer, while the mast remains firmly against the side of the truck/trailer. This allows the operator to lift full capacity loads at maximum reach while retaining the ability to tilt and side shift at all times—ensuring safe load handling. In addition, the reduced pallet and truck bed damage risk is a key advantage as the operator can lift their load free and clear of the deck.

## 4-WAY

Narrow roadways, paths and openings present special challenges for delivery of long loads such as lumber. This requires an agile 4-way directional forklift that can travel sideways with the load to reach the desired delivery location.



### FHS 55 4W

The 4-way mode selection is as simple as the flip of a switch and within seconds you're ready to travel sideways to your final delivery point. For additional safety in standard and in 4-way mode, the FHS 55 4W is equipped with independent brakes on all 3 wheels.



### FHS 55 4WP REACH

The PALFINGER FHS 55 4WP is the perfect solution for difficult, same side loading/unloading situations. The reach system allows the operator to lift full capacity loads from across the truck bed or trailer, while the steering can be switched to the front wheels to allow effortless sideways driving with the minimal space requirement.

# TECHNICAL SPECIFICATIONS

## FHS 55

|     | MODEL   | FHS 55 STD  | FHS 55 P                                      |
|-----|---|---|---|
|     | TYPE  | Standard  | Reach   |
| 1   | CAPACITY @ 24" LOAD CENTER                                | 5,500 lbs.  | 5,500 lbs.                                    |
| 2   | DIESEL ENGINE   | 56 hp   | 56 hp   |
| 2a  | ENGINE EMISSION COMPLIANCE EPA                            | TIER 4 Final                                      | TIER 4 Final                                  |
| 3   | MAXIMUM ENGINE RPM  | 2,700 rpm   | 2,700 rpm                                     |
| 4   | ELECTRICAL SYSTEM   | 12 Volt   | 12 Volt                                       |
| 5   | DRIVE WHEELS (ALL WITH BRAKES)                            | 3   | 3   |
| 6   | STEERING  | Hydrostatic                                       | Hydrostatic                                   |
| 7   | TIRE TYPE FRONT : SKID STEER                              |   |   |
|     | TIRE TYPE: TRACTOR GRIP                                   | 31" x 15.5" - 15" 8 PLY                           | 31" x 15.5" - 15" 8 PLY                       |
| 8   | TIRE OUTSIDE DIAMETER                                     | 31"   | 31"   |
| 9   | TIRE WIDTH  | 15 1/2"   | 15 1/2"                                       |
| 10  | MAXIMUM SPEED   | 7 mph   | 7 mph   |
| 11  | MAXIMUM GRADABILITY                                       | 30%   | 30%   |
| 12  | TURNING RADIUS  | 75"   | 81"   |
| 13  | UNLADEN WEIGHT EXCLUDING FORKS                            | 120" MAST 6,220 lbs.   144" MAST 6,340 lbs.       | 120" MAST 7,270 lbs.   144" MAST 7,390 lbs.   |
| 14  | WORKING PRESSURE FOR ATTACHMENTS                          | 3,000 psi   | 3,000 psi                                     |
| 15  | TILT OF MAST (FORWARD / BACK)                             | 10° / 8°  | 10° / 8°                                      |
| 15a | TILT OF FORK CARRIAGE (FORWARD / BACK)                    |   | 0° / 6°                                       |
| 16  | SIDESHIFT   | 6"  | 5"  |
| 17  | FORK SECTION: PALLET   BRICK / BLOCK   LUMBER (L x W x H) | 48" x 4" x 1 3/4"   48" x 2" x 2"   48" x 6" x 2" | 48" x 4" x 2"   48" x 2" x 2"   48" x 6" x 2" |
| 18  | MAST CARRIAGE TRAVEL                                      | 31.5"   | 37.4"   |
| 18a | REACH ACROSS TRUCK BED                                    |   | 51"   |
| 19  | COUNTERWEIGHTS  | No  | No  |
| A   | HEIGHT TO TOP OF CANOPY                                   | 101"  | 101"  |
| B   | FORK CARRIAGE WIDTH                                       | 47 1/4" (CLASS IV 25" OPENING)                    | 47 1/4" (CLASS IV 25" OPENING)                |
| C   | FRAME OPENING   | 58"   | 58"   |
| D   | OVERALL WIDTH   | 101 1/2"  | 101 1/2"                                      |
| E   | OVERHANG  | 60"   | 66"   |
| F   | WHEEL BASE  | 65 1/2"   | 71 1/2"                                       |
| G   | C. OF G. FROM FORK FACE                                   | 18 3/4"   | 20 1/2"                                       |
| H1  | LIFT HEIGHT   | 120"   144"                                       | 120"   144"                                   |
| H2  | MAST HEIGHT COLLAPSED                                     | 88 3/4"   100 3/4"                                | 88 3/4"   100 3/4"                            |
| H3  | MAST HEIGHT RAISED  | 148 3/4"   172 3/4"                               | 201"   225"                                   |
| J   | GROUND CLEARANCE  | 11"   | 11"   |
| K   | FACE OF FORK TO CENTER OF FRONT TIRE                      | 15"   | 15"   |
| L   | ANSI STANDARD   | B56.14  | B56.14  |

**FHS 55 4W****FHS 55 4WP**

| 4 Way                                       | 4 Way Reach                                 |
|---|---|
| 5,500 lbs.                                  | 5,500 lbs.                                  |
| 56 hp                                       | 56 hp                                       |
| TIER 4 Final                                | TIER 4 Final                                |
| 2,700 rpm                                   | 2,700 rpm                                   |
| 12 Volt                                     | 12 Volt                                     |
| 3   | 3   |
| Hydrostatic                                 | Hydrostatic                                 |
| 31" x 13" - 16.5" 10 PLY                    | 31" x 13" - 16.5" 10 PLY                    |
| 31" x 15.5" - 15" 8 PLY                     | 31" x 15.5" - 15" 8 PLY                     |
| 31"/31"                                     | 31"/31"                                     |
| 13"/15 1/2"                                 | 13"/15 1/2"                                 |
| 7 mph                                       | 7 mph                                       |
| 30% (15%)                                   | 30% (15%)                                   |
| 75"   | 81"   |
| 120" MAST 6,925 lbs.   144" MAST 7,045 lbs. | 120" MAST 7,985 lbs.   144" MAST 8,105 lbs. |
| 3,000 psi                                   | 3,000 psi                                   |
| 10°/8°                                      | 10°/8°                                      |
| 6"  | 5"  |
| 48" x 6" x 2"                               | 48" x 6" x 2"                               |
| 31.5"                                       | 37.4"                                       |
|   | 51"   |
| No  | No  |
| 101"  | 101"  |
| 47 1/4" (CLASS IV 25" OPENING)              | 47 1/4" (CLASS IV 25" OPENING)              |
| 58"   | 58"   |
| 101 1/2"   101"                             | 101 1/2"   101"                             |
| 60"   | 66"   |
| 65 1/2"                                     | 71 1/2"                                     |
| 17"   | 17 3/4"                                     |
| 120"   144"                                 | 120"   144"                                 |
| 88 3/4"   100 3/4"                          | 88 3/4"   100 3/4"                          |
| 148 3/4"   172 3/4"                         | 201"   225"                                 |
| 11"   | 11"   |
| 15"   | 15"   |
| B56.14                                      | B56.14                                      |

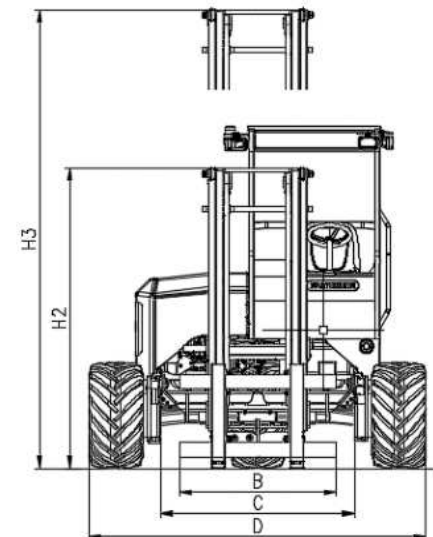
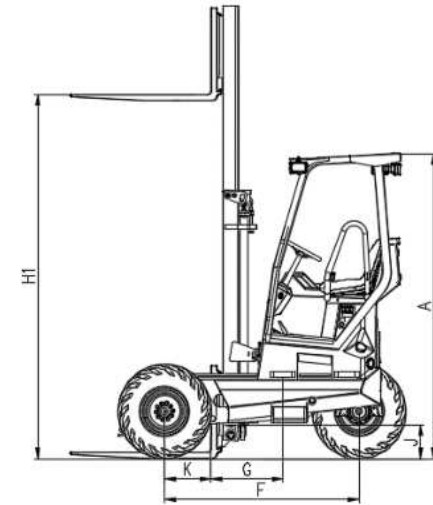

Weights will change depending on wheel and fork options.  
Weights listed do not include forks or accessories.

