

PAL Pro 20 Mechanics Truck Ford F-350 Crew

Cab 4x4



FORD

## PAL PRO 20 MECHANICS TRUCK

### F-350 CREW CAB 4X4

STOCK NUMBER: 1976074

NEW

AVAILABLE



#### OFFER INFORMATION

Location details

4000 Irving Blvd, Dallas, TX, 75247 - United States



Dealer Name

Rush Truck Center



Availability

Available

Product type

New

Stock number

1976074

Contact person

Dub Davis

Dealer E-mail

davisw@rushenterprises.com

Dealer phone

1-214-773-2563

**\$ 119,900**

Prior sale and changes reserved!

Print date: Apr 5, 2026, 7:35:28 PM

## Cab 4x4

**CRANE BODY TECHNICAL DETAILS**

- PCB 20 Series 9 ft heavy duty galvanized steel crane body
- Standard right rear crane mounting compartment
- Compartment tops reinforced with structural angle
- Six recessed cargo tie downs with 6,000 lb capacity
- Two grab handles
- 40 in high side compartments
- Optional compartments can be raised to 60 in with additional structural gusseting
- Masterlock compartment locking system
- Fully integrated and sealed automotive style harness kit
- FMVSS 108 LED light and reflector kit
- Mudflap brackets included
- Entire body electro coat (E Coat) primer
- Understructure and bottom of compartments undercoated
- Body installation kit included for Class 3 to 5 chassis cab with 60 in CA for Ford, GM, and RAM
- Designed to accept up to a 20,000 ft lbs rated crane

**SERVICE CRANE TECHNICAL DETAILS**

- PALFINGER model PSC 3216** telescopic service crane
- 12,500 ft. lbs. capacity
  - 16 ft reach capability
  - One hydraulic extension and one manual extension
  - 4,000 lb vertical lift capacity
  - Boom elevation range from -5° to +80°
  - Double acting cylinders with load holding valves on all cylinders
  - Overload shutdown system
  - Wireless radio remote controller (pistol grip)
  - Toggle controller with 36 ft pendant
  - Crane decals included
  - Crane hook included
  - Load line block included
  - Ecoat prime finish
  - White topcoat paint
  - Crane tie down bolt kit included
  - Available for use on vehicles above 10,001 GVW

**COMPRESSOR TECHNICAL DETAILS**

No Compressor Available. Can add upon request.

**CHASSIS DETAILS**

Ford F-350 Super Cab

- 6.7l Power Stroke Diesel
- 4x4
- XL Chrome Package
- 14,000 Lb. GVWR
- Skid Plates
- Running Boards



- Trailer Brake Controller
- Heavy Duty Front Suspension
- Backup Camera
- Remote Start

# MECHANICS BODY PAL Pro 20

Mechanics Bodies, Service Cranes & Compressors  
Built for the Modern Work Truck.

**LIFETIME EXCELLENCE**





With the best equipment for the job, add a competitive edge to your business in a range of industries. Our mechanics trucks are a reliable partner in: Construction, Roadway, Railway, Agriculture, Oil & Gas, Mining, Utilities and Municipalities.



#### **APPLICABLE CRANE MODELS**

- PSC 3216
- PSC 4016
- PSC 4025

#### **APPLICABLE COMPRESSORS**

- PRC 45V



# HIGHLIGHTS

The PAL Pro 20 is our newest light-weight mechanics body in 9' and 11' standard configurations built to accommodate service cranes up to 20,000 ft\*lbs. of lifting capacity. Designed with two-piece doors bonded with automotive adhesive instead of welding, full length channel drip rails, reinforced raised compartments and compartment tops, 316 marine grade stainless steel hinges, and 3 point latching on all doors for added security. All these features, and more, come standard on the PAL Pro 20 package.

Rely on the right equipment for the job with a factory designed, built and tested mechanics body.

### NON-MARRING BOOM REST

Adjustable non-marring boom support E-coated black.

### DOOR DESIGN ELIMINATE WELDING

Double panel doors with internal C-channel stiffeners, adhered with structural adhesive.



### HINGES SECURITY & RUST PREVENTION

316 marine grade stainless steel hinges with concealed leaves and full length rods for combating rust and improving theft prevention.

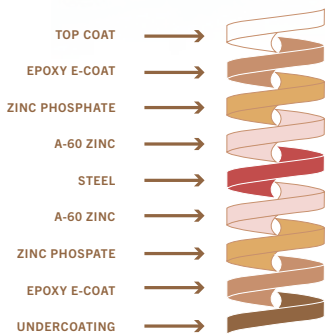

### E-COAT CORROSION PROTECTION

PALFINGER's 12 step electrophoretic deposition dip process cleans the body and applies primer to the metal surfaces, ensuring complete coverage and automotive grade corrosion protection.

### SIDEPACK REINFORCED MOUNT UP

All compartment tops are reinforced to prevent fatigue and cracking when heavy items like welders, tool boxes, and compressors are mounted to the top of your body.

### INTERNAL GUSSETS PREVENTS BODY CRACKING

Every raised compartment comes with PALFINGER's engineered gussets for increased protection against the body cracking in the door corner.



# FEATURES

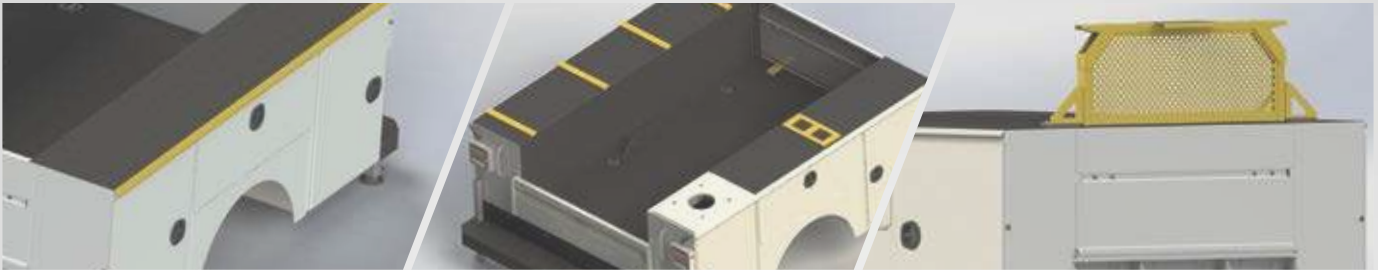

## **DRIP RAIL STAY DRY**

Full length channel drip rails divert water away from the compartment openings.

## **THREADED WELDMENT OPTIONS TO PROTECT YOUR BODY**

Boom rest, welder, compressor, EnPak, Air-n-Arc and AirPak mounts are available from the factory to eliminate the need to drill holes in the body.

## **HEADACHE RACK SAVES COSTLY REPAIRS**

This light bar bracket with a punched screen prevents cargo area contents from making contact with the rear window of the cab – saving you from costly rear window repairs and cleanup.



## **ALUMINUM DIVIDER TRAYS LIGHT WEIGHT SHELVEING**

Aluminum divider trays designed to reduce weight and resist corrosion.

## **ALUMINUM ROLL OUT DRAWERS LIGHT WEIGHT STORAGE**

Tool drawer units options available in aluminum with 4 longitudinal dividers and padded floors.

## **3 POINT COMPRESSION LATCHES IMPROVED SECURITY & SEALING**

Latches are designed for added security and solid contact with the automotive bulb seal on the door frame

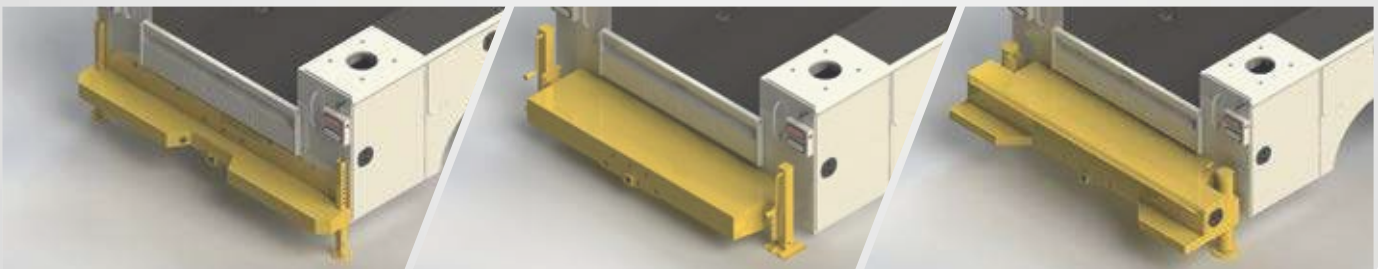

## **STEP BUMPERS LIGHT WEIGHT LOAD SPACE ACCESS**

10" or 17" tread plate step bumper with recess for hitch receiver and crank down outriggers or drop down stabilizers.

## **20" WORK BENCH BUMPER HEAVY DUTY WORK SURFACE**

20" deep work bench bumper with hitch receiver and bolt on manual or hydraulic outriggers.

## **WORK BENCH W/ THRU COMPARTMENT STORAGE & HEAVY DUTY WORK SURFACE**

12" or 21" work bench bumper with hitch receiver and cross tube for extending manual or hydraulic outriggers.

## STANDARD CONFIGURATIONS

### 20-9

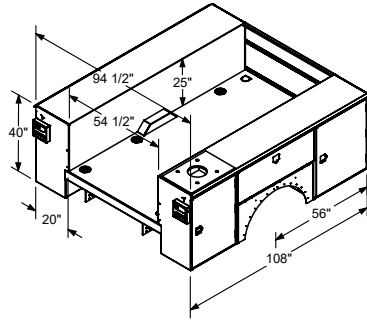

9' standard configuration  
 40" tall compartment heights  
 14" tall one handed tailgate  
 Reinforced compartment tops

### 20-9CS

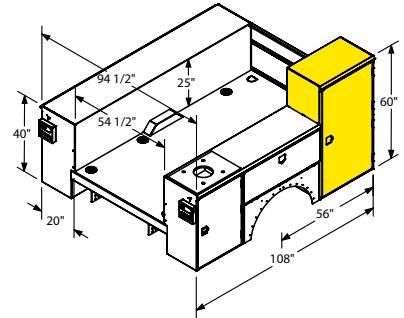

9' standard configuration  
 40" tall compartment heights  
 CS front compartment raised to 60"  
 14" tall one handed tailgate  
 Reinforced compartment tops  
 Reinforced raised compartment

### 20-9SSCS

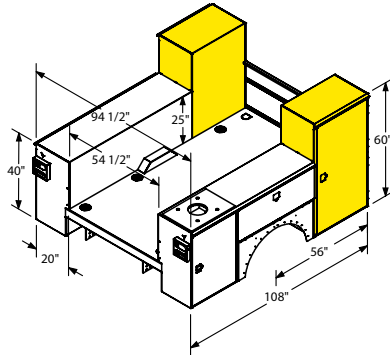

9' standard configuration  
 40" tall compartment heights  
 SS & CS front compartments raised to 60"  
 14" tall one handed tailgate  
 Reinforced compartment tops  
 Reinforced raised compartments

### 20-11

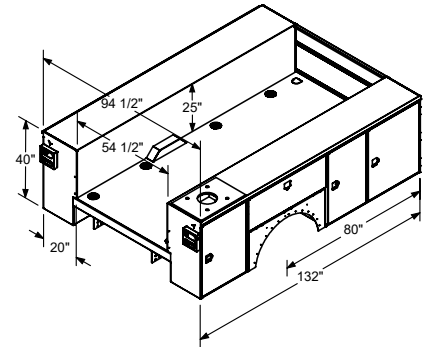

11' standard configuration  
 40" tall compartment heights  
 14" tall one handed tailgate  
 Reinforced compartment tops

### 20-11CS

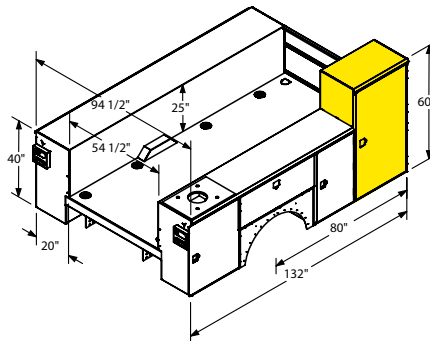

11' standard configuration  
 40" tall compartment heights  
 CS front compartment raised to 60"  
 14" tall one handed tailgate  
 Reinforced compartment tops  
 Reinforced raised compartment

### 20-11SSCS

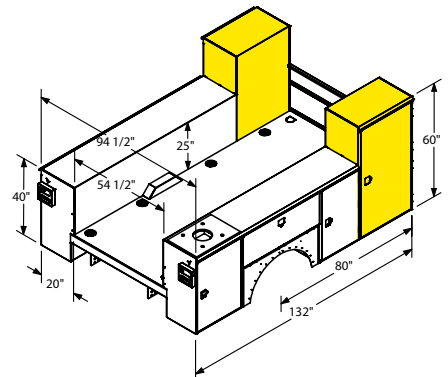

11' standard configuration  
 40" tall compartment heights  
 SS & CS front compartments raised to 60"  
 14" tall one handed tailgate  
 Reinforced compartment tops  
 Reinforced raised compartments

## SERVICE CRANE

# PRODUCT RANGE

### TECHNICAL SPECIFICATIONS

MODEL	CAPACITY	RATED LIFTING MOMENT	MAX LIFTING MOMENT	BOOM EXTENSIONS	BOOM LENGTH	WINCH SPEED	STANDARD WEIGHT	CHASSIS SPECIFICATION
PSC 3216 E	4,000 lbs. (1,814 kg)	12,500 ft*lbs. (17 kNm (1.7 mt))	14,560 ft*lbs. (19.6 kNm (2 mt))	1 Hydraulic + 1 Manual (2 Hydraulic Option)	16 ft. (4.9 m)	21.2 ft./min (6.46 m/min)	650 lbs. (295 kg)	Class 3
PSC 3216 H	4,000 lbs. (1,814 kg)	12,500 ft*lbs. (17 kNm (1.7 mt))	14,560 ft*lbs. (19.6 kNm (2 mt))	1 Hydraulic + 1 Manual (2 Hydraulic Option)	16 ft. (4.9 m)	29.7 ft./min (9.05 m/min)	630 lbs. (286 kg)	Class 3
PSC 4016 E	4,000 lbs. (1,814 kg)	18,500 ft*lbs. (25.1 kNm (2.6 mt))	23,235 ft*lbs. (31.4 kNm (3.2 mt))	1 Hydraulic + 1 Manual (2 Hydraulic Option)	16 ft. (4.9 m)	21.2 ft./min (6.46 m/min)	650 lbs. (295 kg)	Class 3
PSC 4016 H	4,000 lbs. (1,814 kg)	18,500 ft*lbs. (25.1 kNm (2.6 mt))	23,235 ft*lbs. (31.4 kNm (3.2 mt))	1 Hydraulic + 1 Manual (2 Hydraulic Option)	16 ft. (4.9 m)	29.7 ft./min (9.05 m/min)	630 lbs. (286 kg)	Class 3
PSC 4025 E	4,000 lbs. (1,814 kg)	18,500 ft*lbs. (25.1 kNm (2.6 mt))	20,585 ft*lbs. (27.9 kNm (2.9 mt))	2 Hydraulic	25 ft. (7.6 m)	21.2 ft./min (6.46 m/min)	1,010 lbs. (458 kg)	Class 3
PSC 4025 H	4,000 lbs. (1,814 kg)	18,500 ft*lbs. (25.1 kNm (2.6 mt))	20,585 ft*lbs. (27.9 kNm (2.9 mt))	2 Hydraulic	25 ft. (7.6 m)	29.7 ft./min (9.05 m/min)	995 lbs. (451 kg)	Class 3
PSC 5025 E	5,000 lbs. (2,268 kg)	32,500 ft*lbs. (44.2 kNm (4.5 mt))	36,360 ft*lbs. (49.3 kNm (5 mt))	2 Hydraulic	25 ft. (7.6 m)	18.8 ft./min (5.73 m/min)	1,170 lbs. (530 kg)	Class 4
PSC 5025 H	5,000 lbs. (2,268 kg)	32,500 ft*lbs. (44.2 kNm (4.5 mt))	36,360 ft*lbs. (49.3 kNm (5 mt))	2 Hydraulic	25 ft. (7.6 m)	56 ft./min (17.07 m/min)	1,155 lbs. (525 kg)	Class 4
PSC 6025 E	6,000 lbs. (2,750 kg)	38,500 ft*lbs. (52.2 kNm (5.3 mt))	42,800 ft*lbs. (58.0 kNm (5.9 mt))	2 Hydraulic	25 ft. (7.6 m)	43.3 ft./min (13.20 m/min)	1,280 lbs. (580 kg)	Class 4
PSC 6025 H	6,000 lbs. (2,750 kg)	38,500 ft*lbs. (52.2 kNm (5.3 mt))	42,800 ft*lbs. (58.0 kNm (5.9 mt))	2 Hydraulic	25 ft. (7.6 m)	51 ft./min (15.54 m/min)	1,230 lbs. (560 kg)	Class 4
PSC 8029 H	8,000 lbs. (3,650 kg)	43,000 ft*lbs. (58.3 kNm (5.9 mt))	49,180 ft*lbs. (66.5 kNm (6.8 mt))	2 Hydraulic	29 ft. (8.9 m)	60 ft./min (18.28 m/min)	2,149 lbs. (975 kg)	Class 5
PSC 10829 H	10,800 lbs. (4,900 kg)	62,000 ft*lbs. (84.1 kNm (8.6 mt))	68,900 ft*lbs. (93.2 kNm (9.5 mt))	2 Hydraulic	29 ft. (8.9 m)	60 ft./min (18.28 m/min)	2,407 lbs. (1,092 kg)	Class 6
PSC 12529 H	12,500 lbs. (5,700 kg)	72,000 ft*lbs. (97.6 kNm (10 mt))	79,450 ft*lbs. (107.7 kNm (11 mt))	2 Hydraulic	29 ft. (8.9 m)	60 ft./min (18.28 m/min)	2,731 lbs. (1,239 kg)	Class 6
PSC 14029 H	14,000 lbs. (6,400 kg)	86,000 ft*lbs. (116.6 kNm (11.9 mt))	94,676 ft*lbs. (128.4 kNm (13 mt))	2 Hydraulic	29 ft. (8.9 m)	60 ft./min (18.28 m/min)	2,833 lbs. (1,285 kg)	Class 7



OSP\_PALPRO20\_06/20

Cranes shown in the leaflet are partially optional equipped and do not always correspond to the standard version. All PSC models are subject to change as PALFINGER updates, improves, and technologically advances their cranes and the industry.

**OMAHA STANDARD PALFINGER**  
 3501 S. 11th Street | Council Bluffs, IA  
 51501-0876 | USA  
 T + 1 800 279 2201  
 info@palfingerna.com

**PALFINGER.COM**

# ELECTRIC / HYDRAULIC SERVICE CRANE PSC 3216

LIGHTER | LONGER | STRONGER

LIFETIME EXCELLENCE



DISCLOSURE: Image does not show the standard shipping package.



# BUILT TO LAST

Meeting or exceeding all ASME and OSHA standards, the PSC 3216 can be specified as either an electric/hydraulic or full hydraulic service crane with 4,000 lbs. capacity. Just like all of our service crane models, the PSC 3216 features wireless proportional control and a single weld hexagonal boom design. The crane is exclusively E-coated by PALFINGER for the best rust protection in the industry.

## E-COAT PROTECTION

Most rust resistant telescopic crane on the market



- MEDIA BLAST**  
A high quality process that removes any surface imperfections and provides an optimized surface for E-coating.
- E-COAT**  
Automotive grade and environmentally friendly coating process is applied with precision over the entire product ensuring superior corrosion protection.
- TOP COAT**  
All E-coated steel components receive a top coat finish that ensures maximum durability.

**LIGHTER.**  
PALFINGER's service cranes are as much as **30% lighter** than the competition — without sacrificing strength or reach. Less weight means more payload for tools and supplies necessary on the job site.

**LONGER.**  
Up to **30% longer** than the competition, PALFINGER's service cranes have the longest reach in the industry. More reach means fewer setup adjustments on the job site and improved access for those challenging lifts. Standard boom lengths are 16', 25', and 29' depending on the size of the crane.

**STRONGER.**  
PALFINGER's service cranes are up to **20% stronger** than the competition, with a superior lifting moment rating and load chart to do more work in more places. With PALFINGER's safety systems, including the exclusive winch damage prevention system, lifting more is also safer than ever before.

# STANDARD FEATURES



- PLANETARY WINCH**  
Planetary winch provides speed and durability.
- HORSE HEAD**  
Low profile design. Optional boom tip hook(s) and lights. No A2B components to interfere with operation.
- INTELLIGENT WINCH CONSOLE (IWC)**  
Two-block damage prevention system is integrated into the winch mounting platform eliminating the need for boom tip apparatus and cord reel. Complies with ASME B30.5.

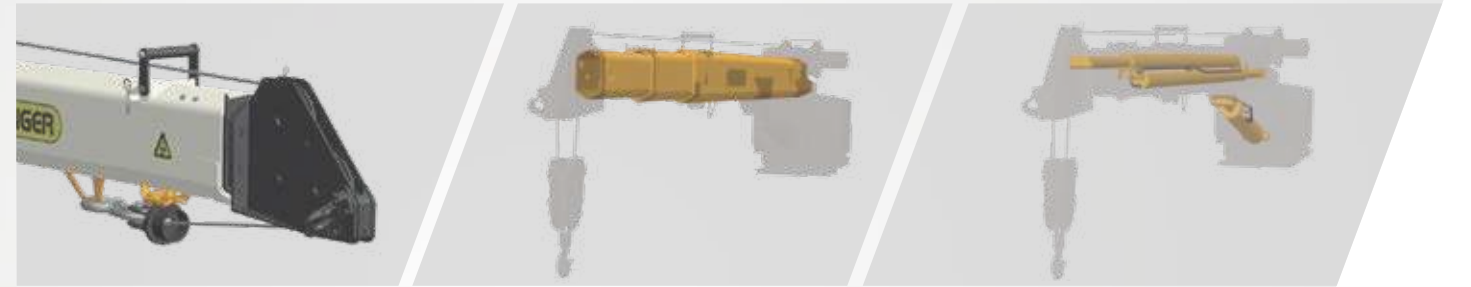

- LOAD BLOCK STOWING BRACKET**  
Bracket and pads designed to keep load block from contacting the boom when stowed.
- HEXAGONAL BOOMS**  
Ultra-low maintenance high tensile strength self-centering single weld boom sections powered by internal extension cylinders.
- CYLINDERS**  
Internal extension cylinders for 16' of outreach (manual tip section). All cylinders are E-coated and use a 5 stage marine grade seal system.



- CONTROL SYSTEM**  
Features a standard proportional wireless remote control unit, integrated E-stop button, warning horn and manual valve activation capability. Cranes are controlled with 12V DC power supply.
- PROPORTIONAL CONTROL**  
Through the control valve, single function proportional control of all hydraulic functions is standard.



**3-YEAR WARRANTY**  
PALFINGER service cranes come with an industry leading 3-year warranty on all structural components

# OPTIMIZED TO WORK HARDER

PALFINGER's small PSC service cranes are the perfect fit for light-duty crane bodies and mechanics bodies. Every crane features 4-bolt installation and weight optimization for maximum payload performance. Choose either electric/hydraulic or hydraulic crane configurations, and pick from a wide range of options and accessories to complete your service truck build with the tools you need. Contact your PALFINGER representative to find the right solution for your business.



## MORE STABLE

PALFINGER's wide range of hydraulic or manual crank outrigger kit options provide stability for your mechanics body or crane-reinforced body/flatbed. Add our 12V Powerpack to an electric crane installation to provide hydraulic power to hydraulic outriggers without requiring a PTO/pump.

## MORE SECURE

PALFINGER boom rests are available in adjustable or fixed configurations and feature easy 4-bolt installation and soft strap saddle design to eliminate marring/scratching of the boom.

## MORE SECURE

Each crane is available with accessories like LED boom tip lights, boom tip hooks and more to turn a small crane into a multi-tool that gets the job done right.

## UPFITTER FRIENDLY

Thanks to a 4-bolt installation pattern and readily accessible installation instructions, mounting a PALFINGER PSC crane is an easy job. Hydraulic accessories are available including flow control valves, hydraulic tanks, and electrical installation kits to maximize the performance of the service crane.

# OPTIONS & ACCESSORIES



### ACOUSTIC 90% LOAD WARNING FOR INCREASED SAFETY

An audible warning communicates to the operator that the service crane is working at 90% load capacity and will soon reach maximum capacity.

### 3RD WRAP LIMITING SYSTEM

Integrated system prevents wire rope spool off, ensuring three wraps remain on drum. Exceeds ASME B30.5.

### BOOM TIP HOOKS

PALFINGER exclusive 1.5 ton capacity boom tip hooks. Available on either or both sides of the boom tip. Horsehead has threaded weldment for mounting.



### OUTRIGGERS FOR ADDED STABILITY

Support your lifting application needs with manual and hydraulic outrigger options.

### BOOM TIP LIGHTING

With the addition of a retractable cord reel we bring power to the boom tip to light dual work lights that swing freely while raising and lowering the boom to illuminate your working area.

### FULLY HYDRAULIC BOOM EXTENSION

Add PALFINGER's dual hydraulic boom extension option to eliminate the manual slide out extension for easier and quicker operation.



### PROTECTIVE CASE WITH BELT LOOP KEEPS REMOTE AT YOUR SIDE

Nylon case with clear plastic cover protects your remote control from harsh weather elements, while the belt loop allows you to attach the remote to your work belt for added convenience on the job.

### SILICONE COVER FOR REMOTE KEEPS REMOTE CLEAN

Flexible silicone cover helps keep dust, dirt, and grime off of your remote control – so you can focus on controlling your service crane and not cleaning the remote.

### REMOTE STORAGE BRACKET SECURELY STOWS REMOTE

Stow the remote control using the metal storage bracket and mount it in the cab or the crane compartment. Thanks to the remote magnet, the remote will be held securely in place during transport.



# TECHNICAL SPECIFICATIONS

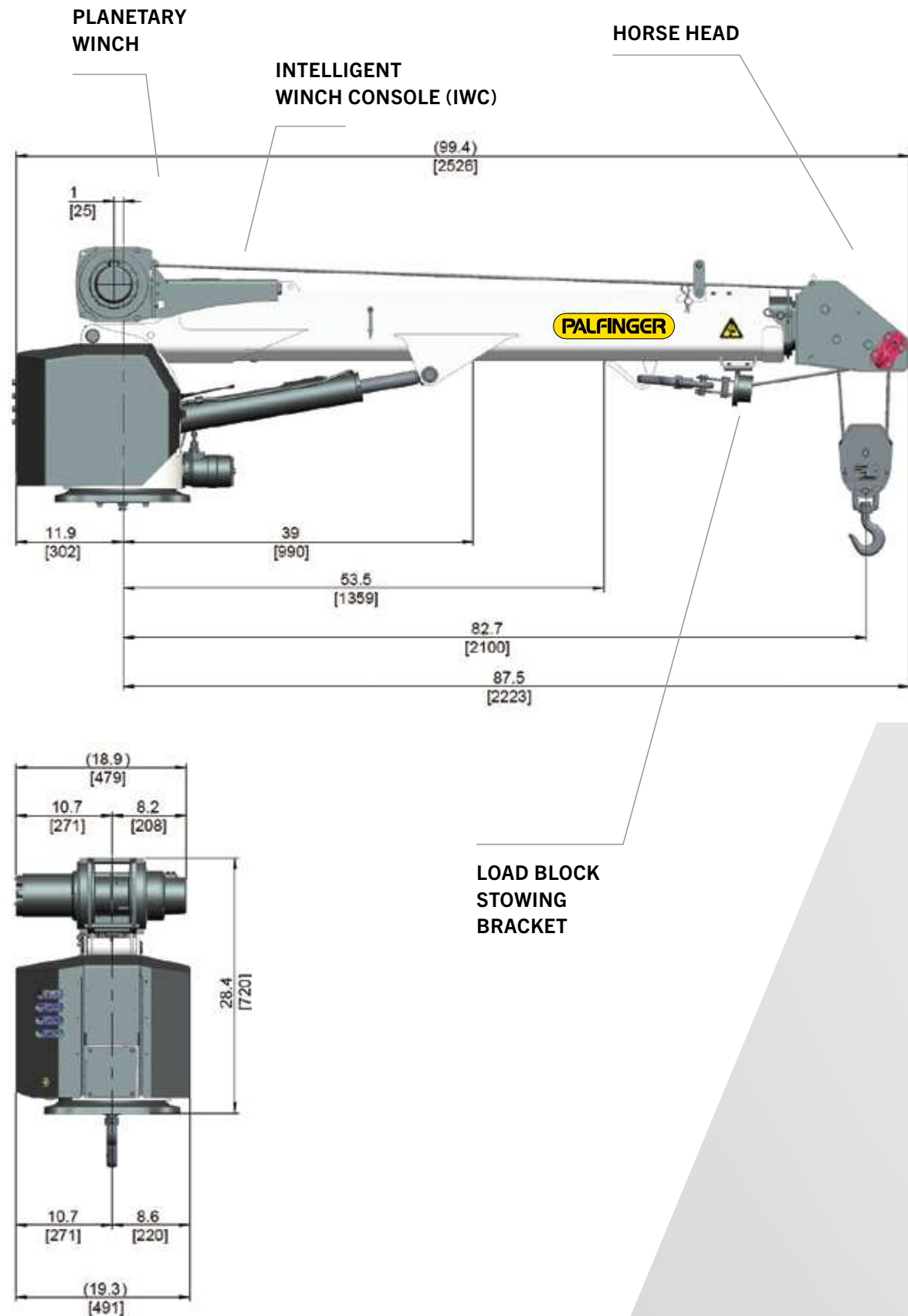

## TECHNICAL SPECIFICATIONS

### CRANE RATING

Rated lifting moment	12,500 ft*lbs. (17.0 kNm (1.7 mt))
Maximum lifting moment	14,560 ft*lbs. (19.6 kNm (2 mt))
Boom extensions	11.4 ft. (3.5 m), 16 ft. (4.9 m)
	1 hydraulic, 1 manual (optional 2 hydraulic)
Crane weight <b>Electric</b>	650 lbs. (295 kg)
Crane weight <b>Hydraulic</b>	630 lbs. (286 kg)
Hydraulically powered extensions	

### CONTROL SYSTEM

- Wireless remote control unit
- Integrated E-stop button
- Manual emergency valve activation capability
- Integrated warning horn
- 12V DC power supply

### ROTATION SYSTEM

Slewing torque	2,130 ft*lbs. (2.9 kNm (0.3 mt))
Slewing angle <b>Electric</b>	Continuous rotation
Slewing angle <b>Hydraulic</b>	410 ° rotation

### STANDARDS (meets or exceeds)

Crane design	ASME B30.5	OSHA 1910.28
Calculation	EN 12999 H1,B6	

### PLANETARY GEAR WINCH

- Max. winch force single line 2,000 lbs. (907 kg)
- Max. winch force double line 4,000 lbs. (1,814 kg)
- Max. line speed **Electric** 21.2 ft./min (6.46 m/min)
- Max. line speed **Hydraulic** 29.7 ft./min (9.05 m/min)
- Cable size and length 1/4" x 80' (6.3 mm x 24.3 m)
- Two-block damage prevention system
- 3rd wrap end stop system option
- Planetary gear winch

### HYDRAULIC SYSTEM

- Operating pressure 2,800 psi (19.3 Mpa (193 bar))
- Required oil flow **Hydraulic** 3.5 GPM (13.2 l/min)
- Electronic overload protection system
- Five stage marine-grade seals on all cylinders
- Non integrated load-holding valves on all cylinders

### CRANE | CHASSIS INTERFACE

Base plate dimension	15" x 15" (380 mm x 380 mm)
Hole pattern	12" x 12" (305 mm x 305 mm)
Mounting bolts	4 x 1" -8 UNC

### CHASSIS RECOMMENDATION

Chassis style	Conventional
Minimum GVWR	Class 3 (10,001 lbs. (4,540 kg))

Weights of load-handling devices are part of the load lifted and must be deducted from the capacity.

....lbs  
....kg

Boxes denote two-part line required.

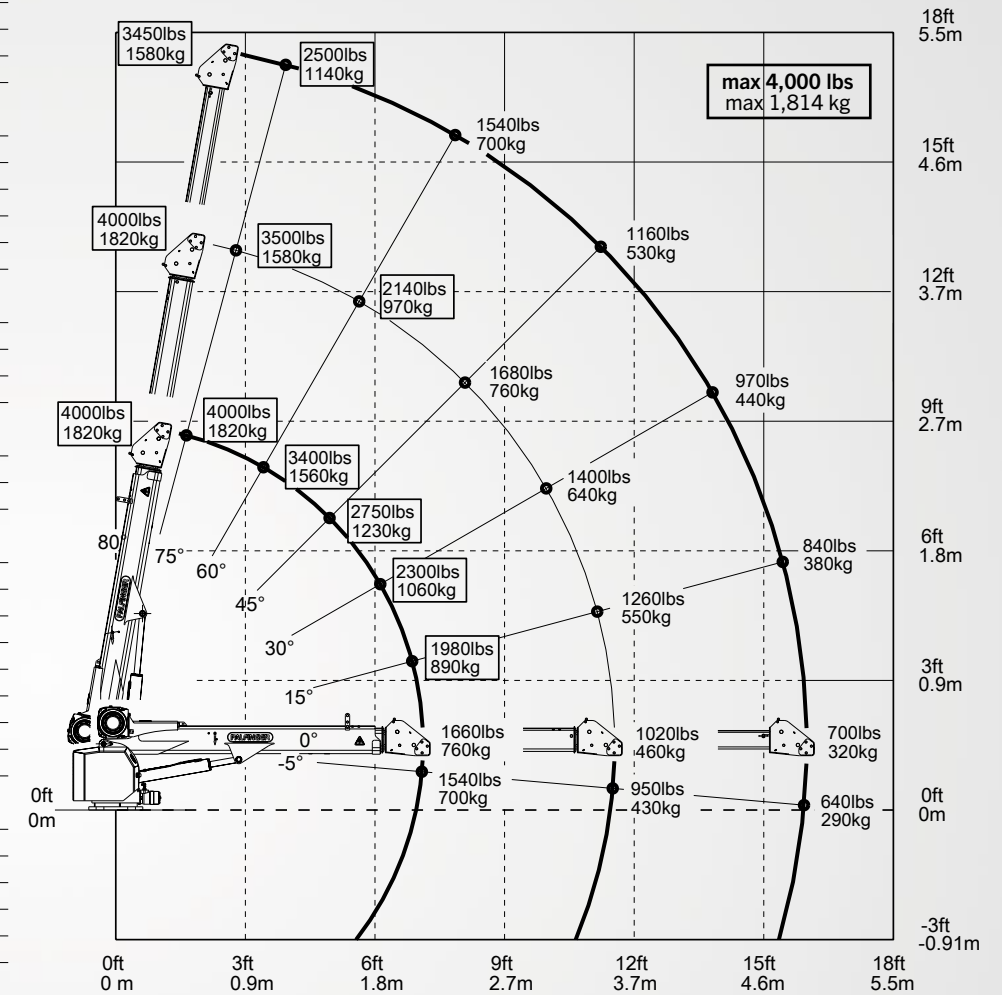

# PRODUCT RANGE

## TECHNICAL SPECIFICATIONS

MODEL	CAPACITY	RATED LIFTING MOMENT	MAX LIFTING MOMENT	BOOM EXTENSIONS	BOOM LENGTH	WINCH SPEED	STANDARD WEIGHT	CHASSIS SPECIFICATION
PSC 3216 E	4,000 lbs. (1,814 kg)	12,500 ft*lbs. (17 kNm (1.7 mt))	14,560 ft*lbs. (19.6 kNm (2 mt))	1 Hydraulic + 1 Manual (2 Hydraulic Option)	16 ft. (4.9 m)	21.2 ft./min (6.46 m/min)	650 lbs. (295 kg)	Class 3
PSC 3216 H	4,000 lbs. (1,814 kg)	12,500 ft*lbs. (17 kNm (1.7 mt))	14,560 ft*lbs. (19.6 kNm (2 mt))	1 Hydraulic + 1 Manual (2 Hydraulic Option)	16 ft. (4.9 m)	29.7 ft./min (9.05 m/min)	630 lbs. (286 kg)	Class 3
PSC 4016 E	4,000 lbs. (1,814 kg)	18,500 ft*lbs. (25.1 kNm (2.6 mt))	23,235 ft*lbs. (31.4 kNm (3.2 mt))	1 Hydraulic + 1 Manual (2 Hydraulic Option)	16 ft. (4.9 m)	21.2 ft./min (6.46 m/min)	650 lbs. (295 kg)	Class 3
PSC 4016 H	4,000 lbs. (1,814 kg)	18,500 ft*lbs. (25.1 kNm (2.6 mt))	23,235 ft*lbs. (31.4 kNm (3.2 mt))	1 Hydraulic + 1 Manual (2 Hydraulic Option)	16 ft. (4.9 m)	29.7 ft./min (9.05 m/min)	630 lbs. (286 kg)	Class 3
PSC 4025 E	4,000 lbs. (1,814 kg)	18,500 ft*lbs. (25.1 kNm (2.6 mt))	20,585 ft*lbs. (27.9 kNm (2.9 mt))	2 Hydraulic	25 ft. (7.6 m)	21.2 ft./min (6.46 m/min)	1,010 lbs. (458 kg)	Class 3
PSC 4025 H	4,000 lbs. (1,814 kg)	18,500 ft*lbs. (25.1 kNm (2.6 mt))	20,585 ft*lbs. (27.9 kNm (2.9 mt))	2 Hydraulic	25 ft. (7.6 m)	29.7 ft./min (9.05 m/min)	995 lbs. (451 kg)	Class 3
PSC 5025 E	5,000 lbs. (2,268 kg)	32,500 ft*lbs. (44.2 kNm (4.5 mt))	36,360 ft*lbs. (49.3 kNm (5 mt))	2 Hydraulic	25 ft. (7.6 m)	18.8 ft./min (5.73 m/min)	1,170 lbs. (530 kg)	Class 4
PSC 5025 H	5,000 lbs. (2,268 kg)	32,500 ft*lbs. (44.2 kNm (4.5 mt))	36,360 ft*lbs. (49.3 kNm (5 mt))	2 Hydraulic	25 ft. (7.6 m)	56 ft./min (17.07 m/min)	1,155 lbs. (525 kg)	Class 4
PSC 6025 E	6,000 lbs. (2,750 kg)	38,500 ft*lbs. (52.2 kNm (5.3 mt))	42,800 ft*lbs. (58.0 kNm (5.9 mt))	2 Hydraulic	25 ft. (7.6 m)	43.3 ft./min (13.20 m/min)	1,280 lbs. (580 kg)	Class 4
PSC 6025 H	6,000 lbs. (2,750 kg)	38,500 ft*lbs. (52.2 kNm (5.3 mt))	42,800 ft*lbs. (58.0 kNm (5.9 mt))	2 Hydraulic	25 ft. (7.6 m)	51 ft./min (15.54 m/min)	1,230 lbs. (560 kg)	Class 4
PSC 8029 H	8,000 lbs. (3,650 kg)	43,000 ft*lbs. (58.3 kNm (5.9 mt))	49,180 ft*lbs. (66.5 kNm (6.8 mt))	2 Hydraulic	29 ft. (8.9 m)	60 ft./min (18.28 m/min)	2,149 lbs. (975 kg)	Class 5
PSC 10829 H	10,800 lbs. (4,900 kg)	62,000 ft*lbs. (84.1 kNm (8.6 mt))	68,900 ft*lbs. (93.2 kNm (9.5 mt))	2 Hydraulic	29 ft. (8.9 m)	60 ft./min (18.28 m/min)	2,407 lbs. (1,092 kg)	Class 6
PSC 12529 H	12,500 lbs. (5,700 kg)	72,000 ft*lbs. (97.6 kNm (10 mt))	79,450 ft*lbs. (107.7 kNm (11 mt))	2 Hydraulic	29 ft. (8.9 m)	60 ft./min (18.28 m/min)	2,731 lbs. (1,239 kg)	Class 6
PSC 14029 H	14,000 lbs. (6,400 kg)	86,000 ft*lbs. (116.6 kNm (11.9 mt))	94,676 ft*lbs. (128.4 kNm (13 mt))	2 Hydraulic	29 ft. (8.9 m)	60 ft./min (18.28 m/min)	2,833 lbs. (1,285 kg)	Class 7



PROUDLY ASSEMBLED  
in the USA

OSP-PSC3216 | 06/20

Cranes shown in the leaflet are partially optional equipped and do not always correspond to the standard version. All PSC models are subject to change as PALFINGER updates, improves, and technologically advances their cranes and the industry.

OMAHA STANDARD PALFINGER  
3501 S. 11th Street | Council Bluffs, IA  
51501-0876 | USA  
T + 1 800 279 2201  
info@palfingerna.com

**PALFINGER.COM**