

ETC 40 IH - Insulated Articulated Telescopic Ford

New F-550 Diesel 4x4



FORD

ETC 40 IH - INSULATED ARTICULATED TELESCOPIC NEW F-550 DIESEL 4X4

NEW

ARRIVING SOON



OFFER INFORMATION

Location details

341 NW 122nd Street, Oklahoma City, OK, 73114 -

United States 

Dealer Name

PALFINGER

Availability

Arriving Soon

Product type

New

Contact person

Chris Shallenberg

Dealer E-mail

c.shallenberg@palfinger.com

Dealer phone

+1-405-479-7468

AERIAL UNIT DETAILS

- 45 ft Working Height
- 30 ft Side Reach
- Insulated boom
- Articulated-Telescopic
- Full Hydraulics Controls
- 180 degree platform rotator
- 24 x 30 Platform

BODY DETAILS

- PALFINGER Steel Service Bed
- 132 in Length + 36 in Tail shelf
- 60 Galvanneal Steel material
- Stainless Latches
- Master lock system for all doors
- LED Lighting
- Non Skid coating on walking surfaces
- CS Tail shelf Side Entry

CHASSIS DETAILS

- New FORD F-550
- 84" CA
- 6.7 Liter Diesel Engine
- Automatic Transmission
- 4x4
- AM/FM/CD Radio

ETC 40 IH

ARTICULATED / TELESCOPIC INSULATED



INSULATED VERSATILITY

The ETC 40 IH is a powerful insulated unit with a host of standard and optional features to satisfy the needs of our customers. With a working height of 45 feet, this unit offers continuous rotation, full pressure hydraulic controls and a 400 pound bucket capacity as standard features. It can be fully customized to a customer's individual need by adding a host of options including two speed throttle, bucket tilt / rescue, bucket cover and others. This model is built to satisfy customer demand for power, reach, and innovative design.



DEPEND ON IT.



ETC 40IH

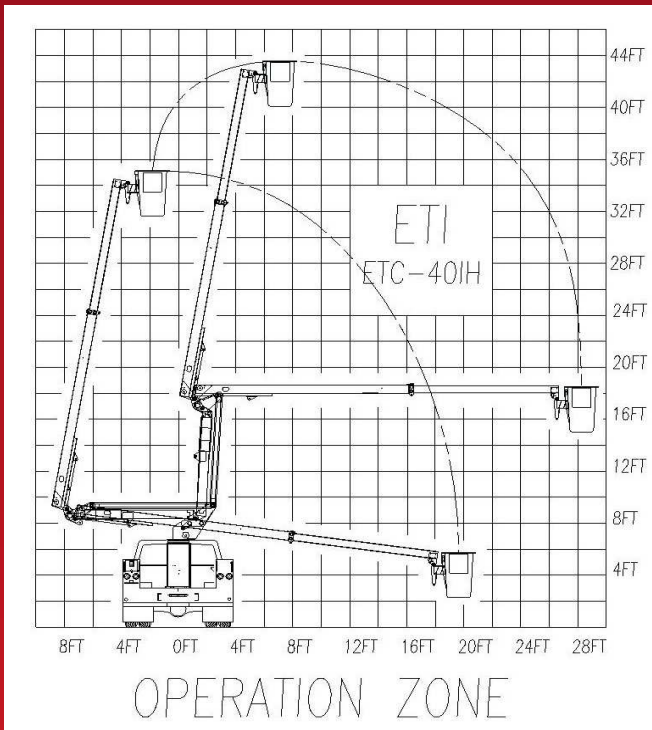

**EQUIPMENT TECHNOLOGY LLC
IS A FULL SERVICE SOLUTION
PROVIDER OF THE HIGHEST
QUALITY DESIGN,
MANUFACTURING, AND POST
SALE SERVICE.**

EQUIPMENT TECHNOLOGY LLC

341 NW 122nd
Oklahoma City, OK 73114
Toll-Free: 1-888-748-3841 • Fax: 1-405-755-6829
etiequipment.com

GENERAL SPECIFICATIONS*

Height to bottom of bucket.....	40ft.-0in.
Working height.....	45ft.-0in.
Sidereach, Endmount.....	29ft.-4in.
Stowed height.....	10ft.-4in.
Rated bucket capacity.....	400lbs.

MINIMUM VEHICLE SPECIFICATIONS

- GVWR (with Dual Rear Wheels)..... 19,500lbs.
- GAWR (front)..... 7,000lbs.
- GAWR (rear)..... 13,500lbs.
- C.A..... 60in.

STANDARD FEATURES

- Continuous rotation is standard on all ETC units.
- Full pressure hydraulic controls located at basket and turret with full feathering capabilities from both upper and lower controls.
- Shear ball rotation with an extended shaft for manual rotation.
- Internally mounted holding valves (integral part of cylinder) lock cylinders in place in the event of hydraulic failure.
- All pins turn on replaceable bushings.
- Single handle upper control.
- Lower boom fiberglass insert.
- 24" x 30" basket.
- 400 lbs. bucket capacity.

OPTIONS

- Emergency hydraulic power (12VDC)
- Engine start/stop at bucket
- Hydraulic tool circuit
- Two speed throttle
- Bucket tilt/rescue
- Bucket liner
- Bucket cover
- 180 degree bucket rotator.
- Two outriggers
- Various DC power options including cab comfort



Specifications are subject to change without notice
Note (*): All specifications are based on 40" frame height