

ETC 35 SNT - Non-Insulated Articulated



Telescopic Ford New F-450 Gas 4x2

FORD

ETC 35 SNT - NON-INSULATED ARTICULATED TELESCOPIC

NEW F-450 GAS 4X2

NEW

ARRIVING SOON



OFFER INFORMATION

Location details

341 NW 122nd Street, Oklahoma City, OK, 73114 -

United States 

Dealer Name

PALFINGER

Availability

Arriving Soon

Product type

New

Contact person

Chris Shallenberg

Dealer E-mail

c.shallenberg@palfinger.com

Dealer phone

+1-405-479-7468

AERIAL UNIT DETAILS

- 40 ft Working Height
- 26' ft Side Reach
- Articulated Telescopic
- Elec/Hydraulics Controls
- 24 x 30 Platform

BODY DETAILS

- PALFINGER Steel Service Bed
- 108 in Length + 36 in Tail shelf
- 60 Galvanneal Steel material
- Stainless Latches
- Master lock system for all doors
- LED Lighting
- Non Skid coating on walking surfaces
- CS Tail shelf Side Entry

CHASSIS DETAILS

- New Ford F-450
- Gas Engine
- Automatic Transmission
- 4x2
- Electric Windows and Locks
- Backup Camera

ETC 35 SNT

ARTICULATED / TELESCOPIC
NON-INSULATED



POWERFUL SOLUTION

The ETC 35 SNT is a non-insulated unit with 40' of working height and 390 degrees of non-continuous rotation. This aerial is an articulated, telescoping model providing the end-user a powerful solution to meet all personnel lifting needs in the field. Bucket mounted controls, variable speed controls and hydraulic bucket leveling are standard on this unit with a multitude of available options to suit each customized need.



DEPEND ON IT.



ETC35SNT

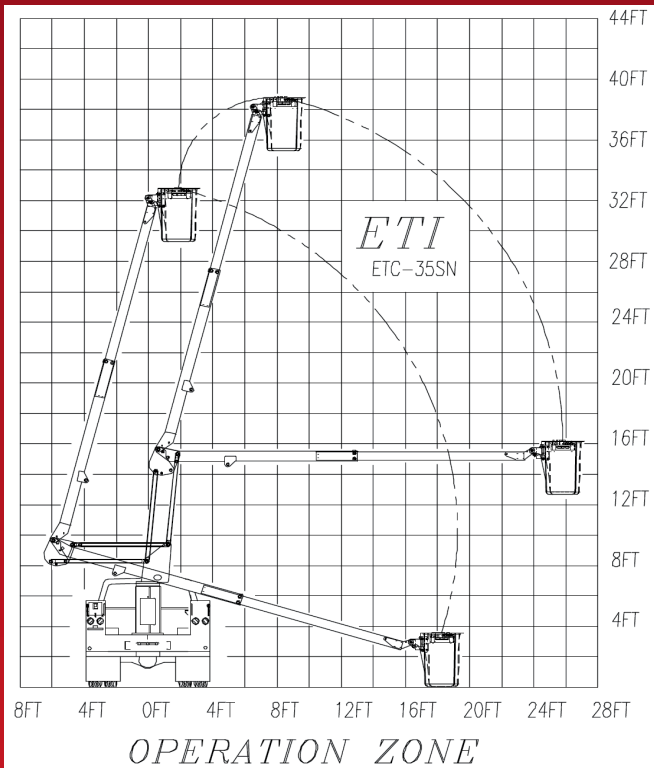

EQUIPMENT TECHNOLOGY LLC IS A FULL SERVICE SOLUTION PROVIDER OF THE HIGHEST QUALITY DESIGN, MANUFACTURING, AND POST SALE SERVICE.

EQUIPMENT TECHNOLOGY LLC

341 NW 122nd
 Oklahoma City, OK 73114
 Toll-Free: 1-888-748-3841 • Fax: 1-405-755-6829
etiequipment.com

GENERAL SPECIFICATIONS*

Height to bottom of bucket	35 ft. - 0 in.
Working height	40 ft. - 0 in.
Side reach, End mount	26 ft. - 0 in.
Rotation	390° Non-continuous
Lower boom articulation	0 to 95 degrees
Upper boom travel	-17 to 75 degrees
Stow height	9 ft. - 9 in.
Rated bucket capacity	350 lbs.

MINIMUM VEHICLE SPECIFICATIONS

- GVWR 16,000 lbs.
- C.A. 60 in

STANDARD FEATURES

- Bucket mounted controls
- Variable speed controls
- Hydraulic bucket leveling
- Emergency upper boom controlled descent
- Engine start/stop at bucket

OPTIONS

- Emergency hydraulic power (12VDC)
- Air line to bucket
- Bridgeframe Hi-Cube body
- 90 degree bucket rotator
- 400 lbs bucket capacity
- Various DC power options
- Single handle control



Specifications are subject to change without notice
 Note (*): All specifications are based on 40" frame height