

MAN

## P 370 KS

### MAN TGM 18.290 4X2 BB CH

CONTRACT NUMBER: 15370217

NEW

SPECIAL OFFER

AVAILABLE NOW



### SPECIFICATION

The P 370 KS is agile, versatile, compact and extremely powerful. This platform combines the best of two worlds. It integrates the impressive flexibility of the WT series and the compact design and well-known counter slewing system of the KS series.

### OFFER INFORMATION

Location details

Löbau, 02708 - Germany 

Dealer Name

Palfinger Platforms GmbH

Product type

New

Contract number

15370217

Dealer E-mail

[sales.platforms@palfinger.com](mailto:sales.platforms@palfinger.com)

Dealer phone

004935854796121

## PRODUCT

<b>Manufacturer</b>	Palfinger	<b>Basket size</b>	2,00 x 0,80 x 1,10 m
<b>Model</b>	P 370 KS	<b>Basket capacity</b>	max. 500 kg
<b>Construction year</b>	2026	<b>Basket turning device</b>	ca. +/- 85°
<b>Outreach</b>	31,50 m	<b>Basket arm angle</b>	185°
<b>Max. height of work</b>	37,00 m	<b>Basket material</b>	Aluminium
<b>Turret rotation</b>	500°		

## TRUCK

<b>Truck manufacturer</b>	MAN	<b>Power</b>	213 kW (290 PS)
<b>Construction year</b>	2022	<b>Emmission standard</b>	EURO6
<b>Drivers cabine</b>	Fahrerhaus CC: das Kompakte (schmal, kurz, normalhoch)	<b>First registration</b>	one day registration 02/2026
<b>Wheel base</b>	3875 mm	<b>TÜV / AU</b>	No GSR II - Special Price

# Working diagrams

## Palfinger P 370KS

on

MAN 18.XXX 16t

The working diagrams shown below have the following preconditions:

**Solid line:**

Standard working diagram

Working height = height of basket bottom + 2.0 m

The basket is in basic position (not turned) and retracted

**The following applies generally:**

All specifications refer to standard aluminum basket without additional equipment

Maximum inclination 0,5°

Set-up inclination is max. 2° with automatic range adjustment.

**Note on working diagram:**

Additional attachments that deviate from the standard reduce range and basket load

Special baskets have different ranges

Reach at plastic workman basket ~ 0,8m reduced

Permitted maximum basket load according to technical description

The outreaches are approximate dimensions and depend on the chassis, the type of support and the lifting platform's additional equipment.

Illustrations of truck and unit are only of symbolic nature and do not allow any conclusions regarding technical design.

Subject to technical change!

# Palfinger P 370KS

## Rear view

Extension of stabiliser  
outrigger

Front left	100%
Front right	100%
Rear left	100%
Rear right	100%

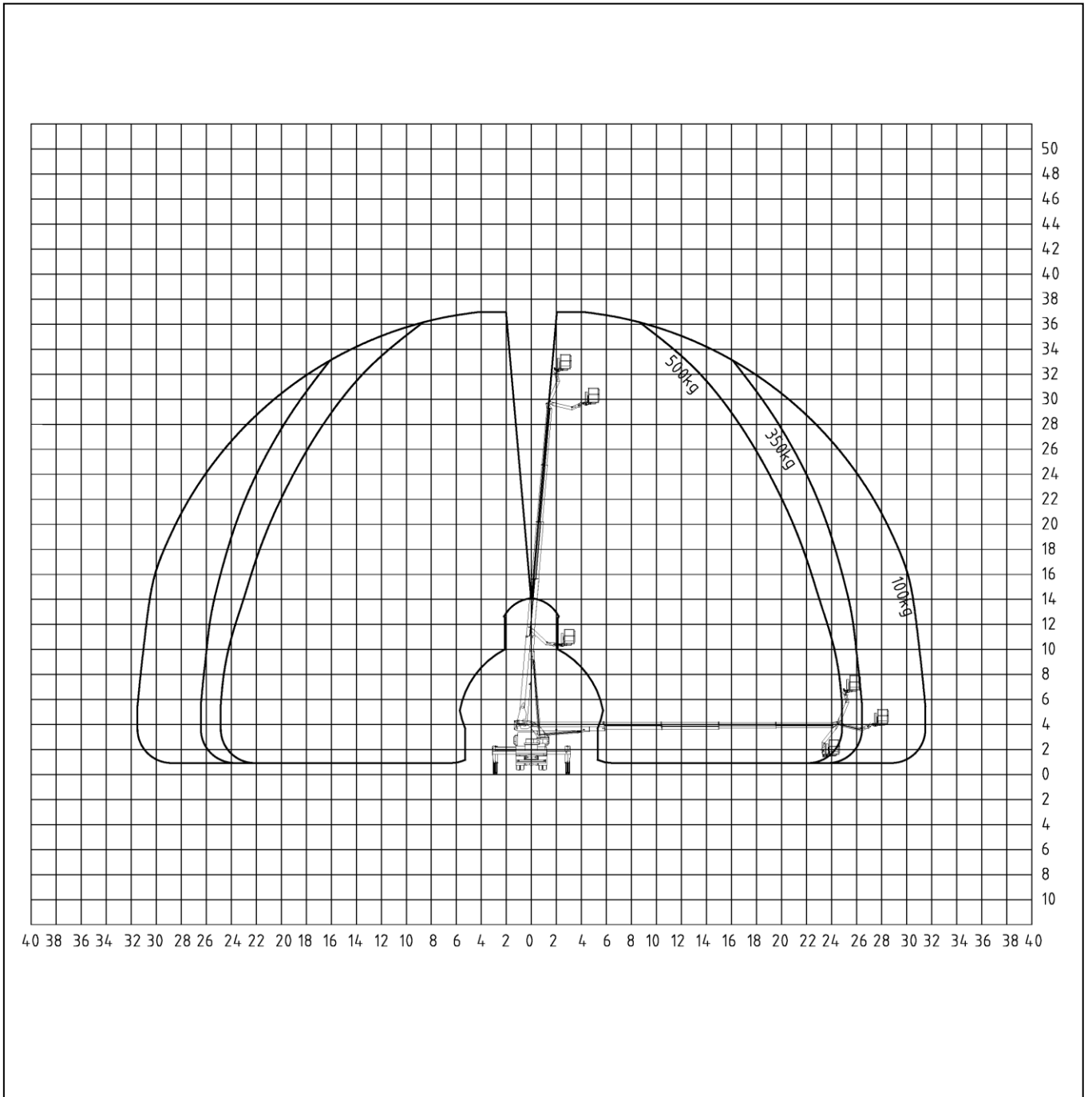

# Palfinger P 370KS

## Top view

Extension of stabiliser  
outrigger

Front left	100%
Front right	100%
Rear left	100%
Rear right	100%

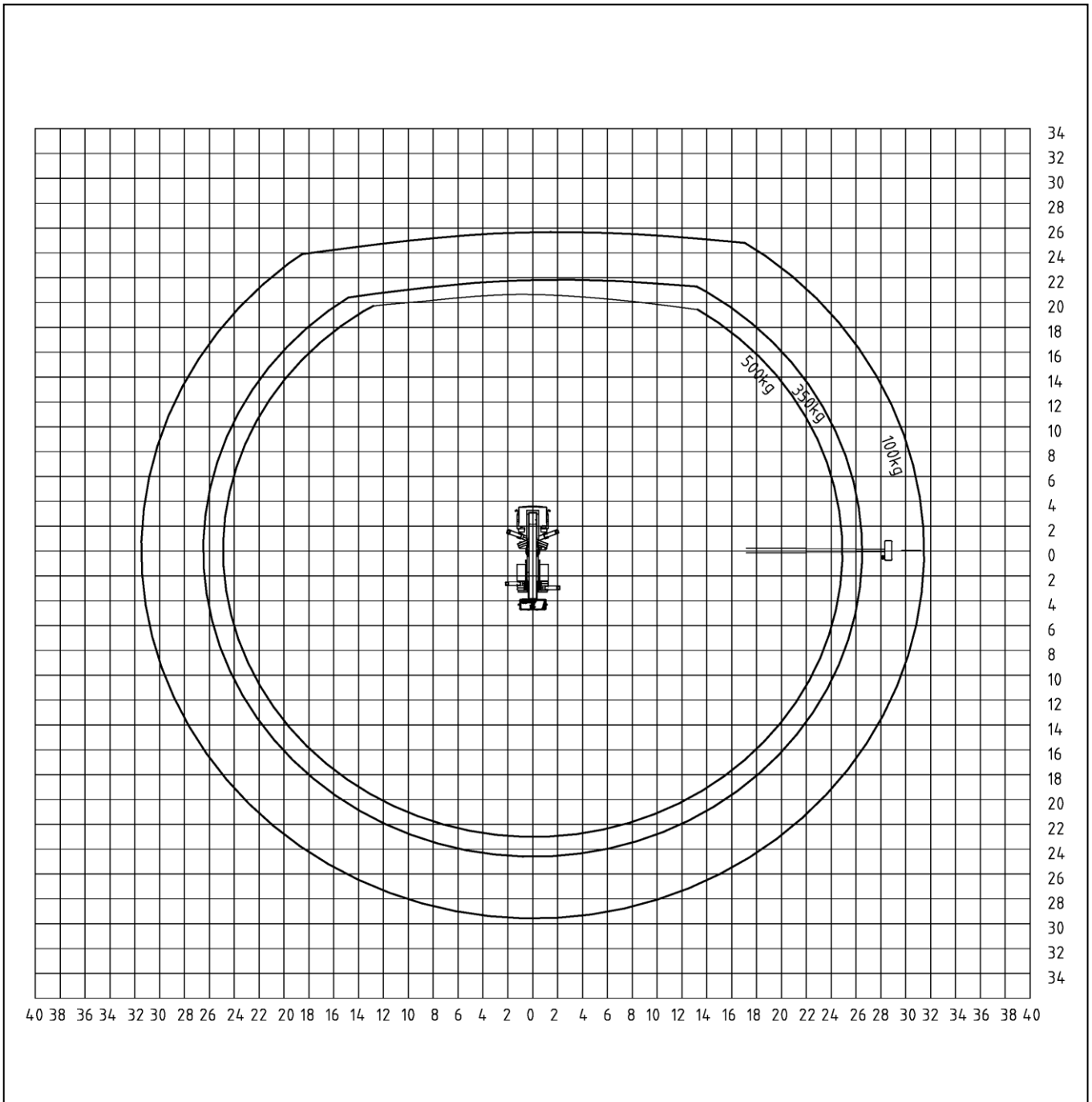

# Palfinger P 370KS

## Left view

Extension of stabiliser  
outrigger

Front left	100%
Front right	100%
Rear left	100%
Rear right	100%

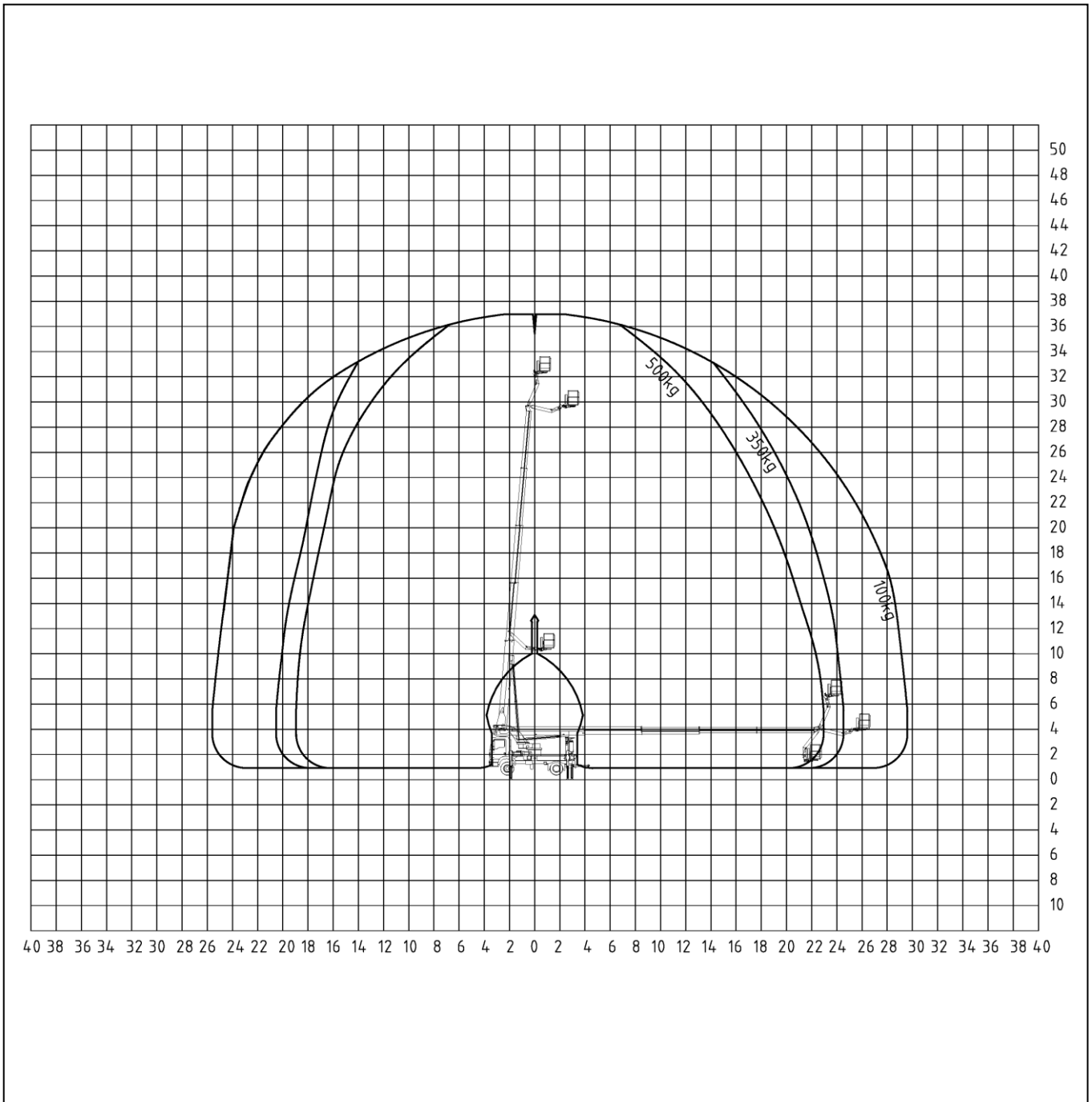

# Palfinger P 370KS

## Rear view

Extension of stabiliser  
outrigger

Front left	50%
Front right	50%
Rear left	50%
Rear right	50%

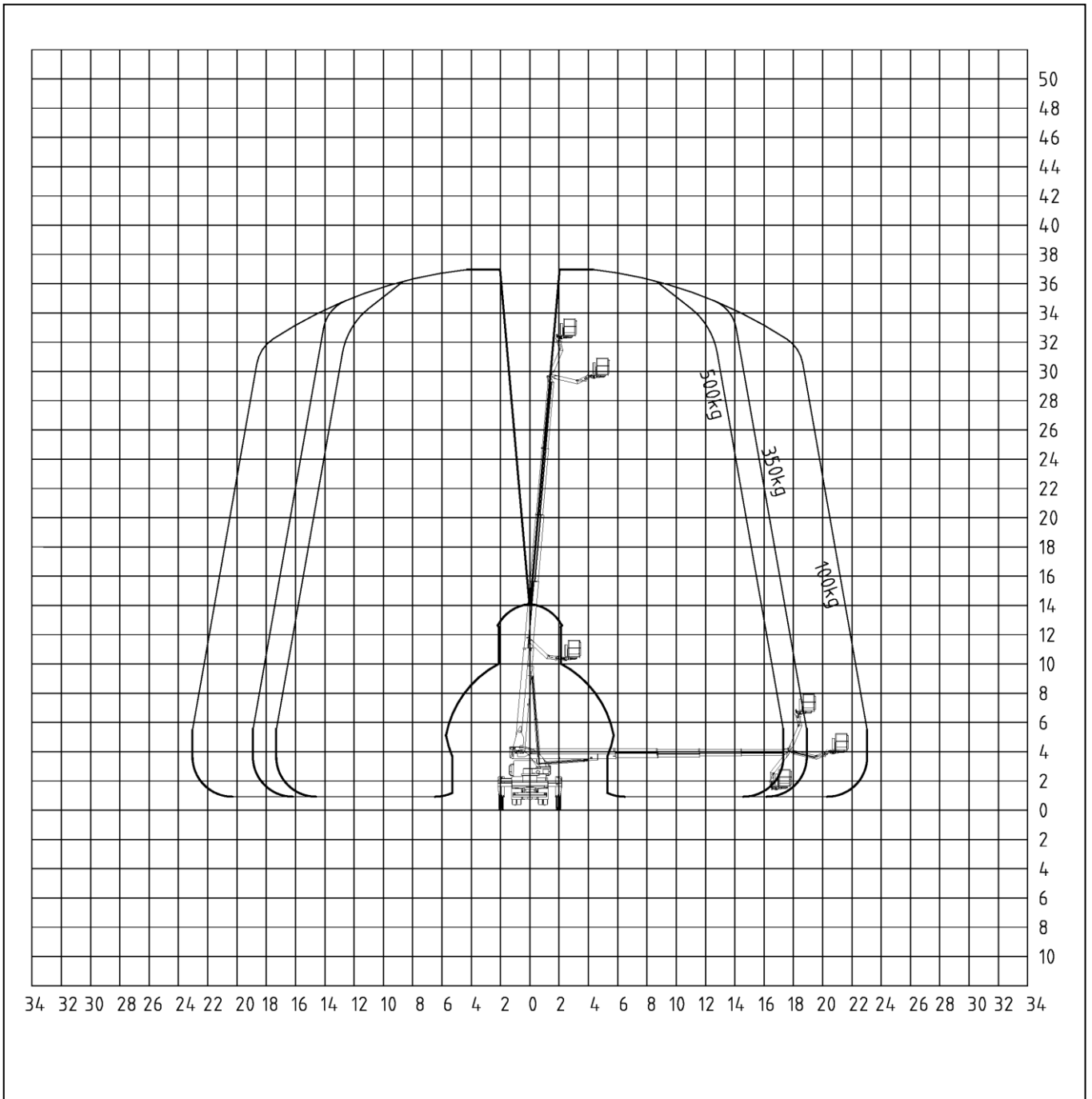

# Palfinger P 370KS

## Top view

Extension of stabiliser  
outrigger

- Front left 50%
- Front right 50%
- Rear left 50%
- Rear right 50%

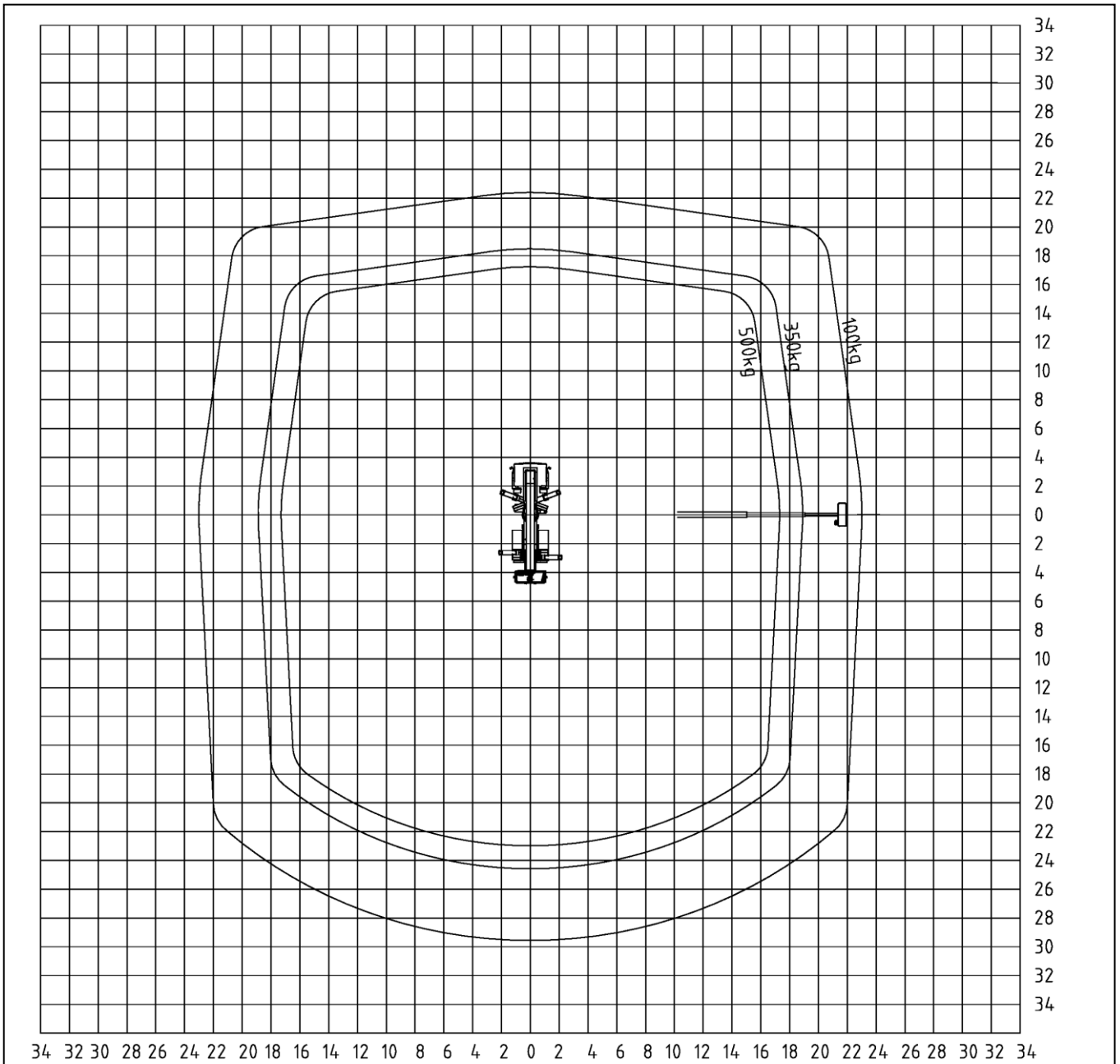

# Palfinger P 370KS

## Left view

Extension of stabiliser  
outrigger

Front left	50%
Front right	50%
Rear left	50%
Rear right	50%

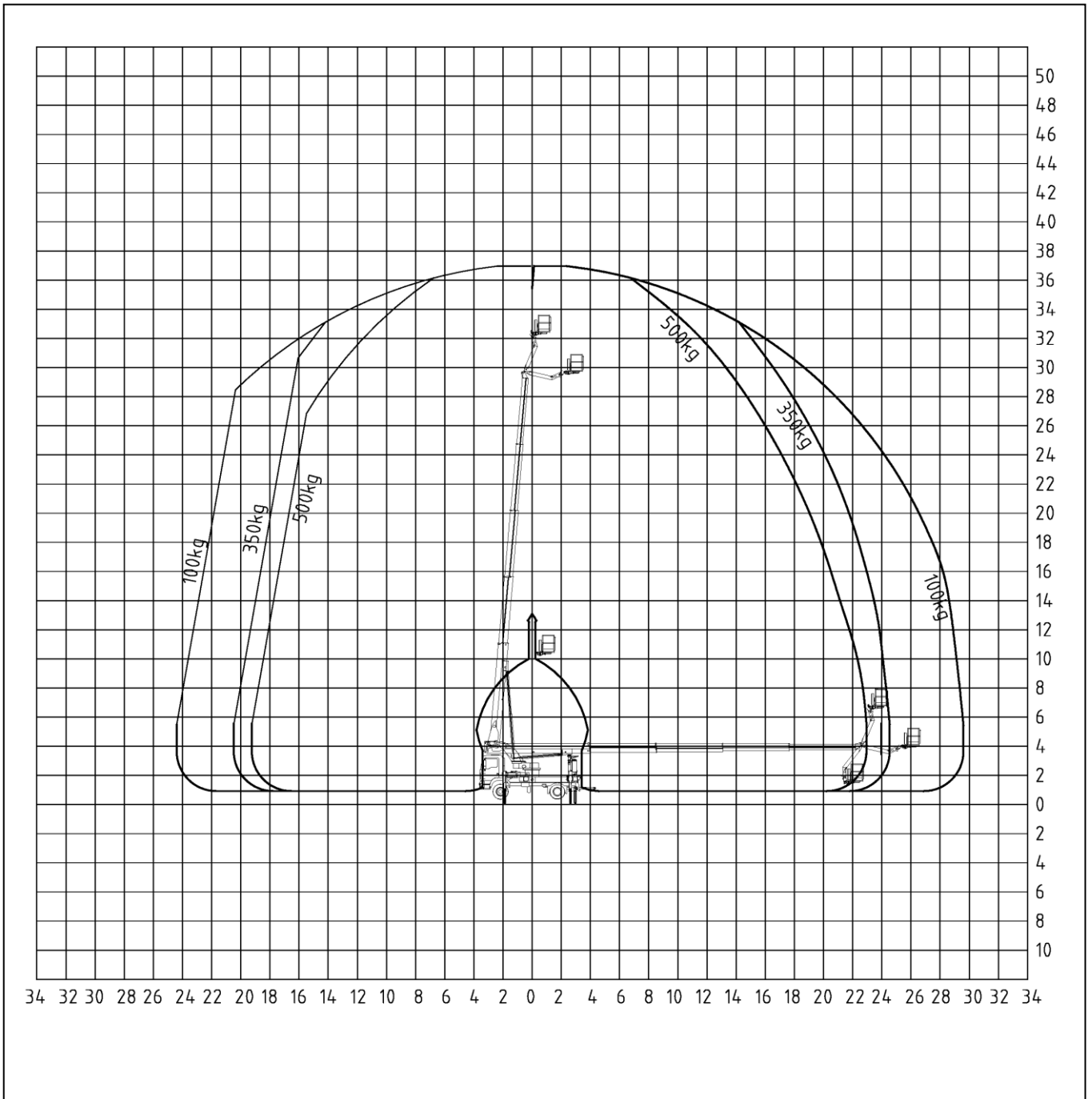

# Palfinger P 370KS

## Rear view

Extension of stabiliser  
outrigger

Front left	0%
Front right	0%
Rear left	0%
Rear right	0%

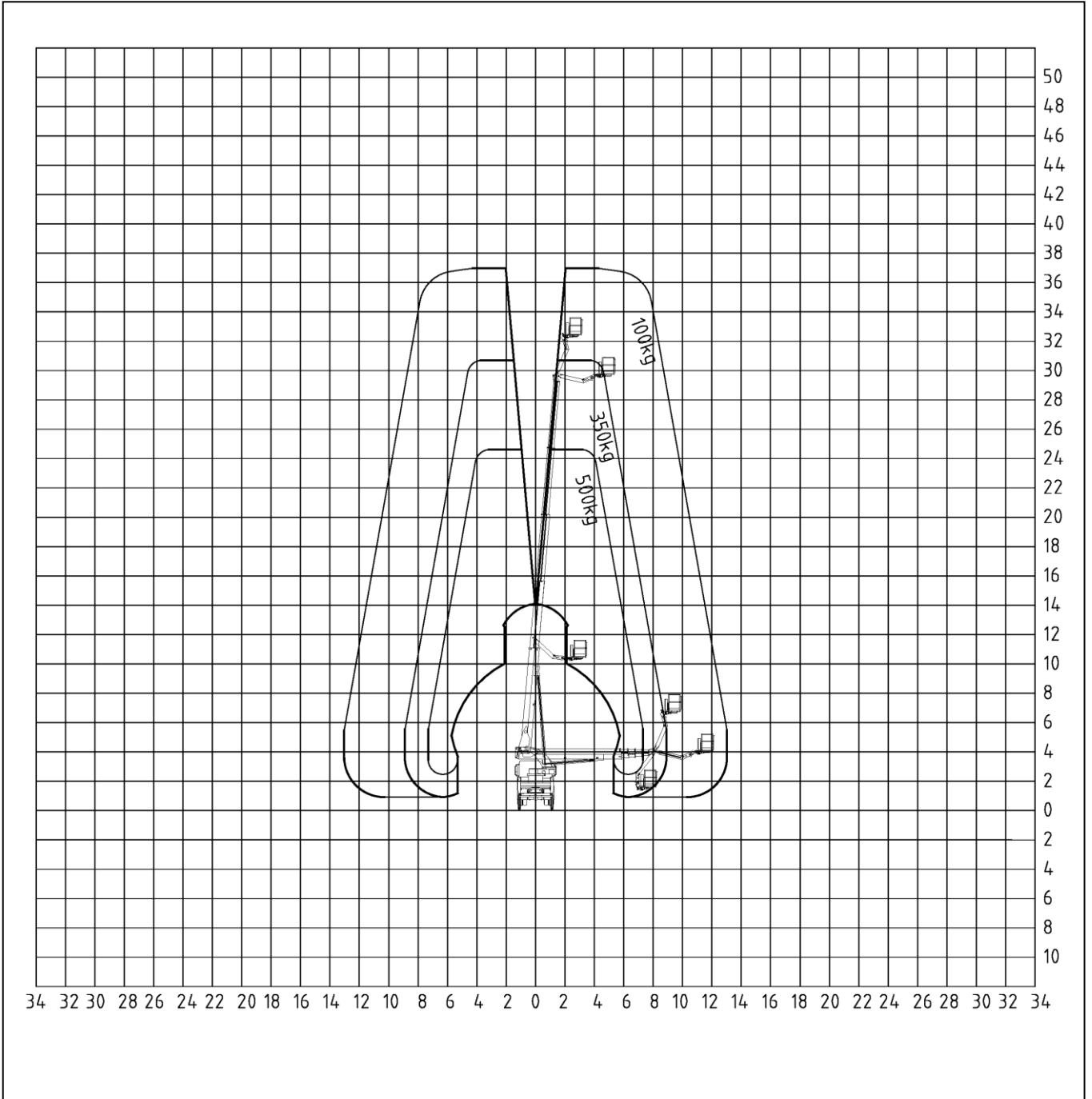

# Palfinger P 370KS

## Top view

Extension of stabiliser  
outrigger

Front left	0%
Front right	0%
Rear left	0%
Rear right	0%

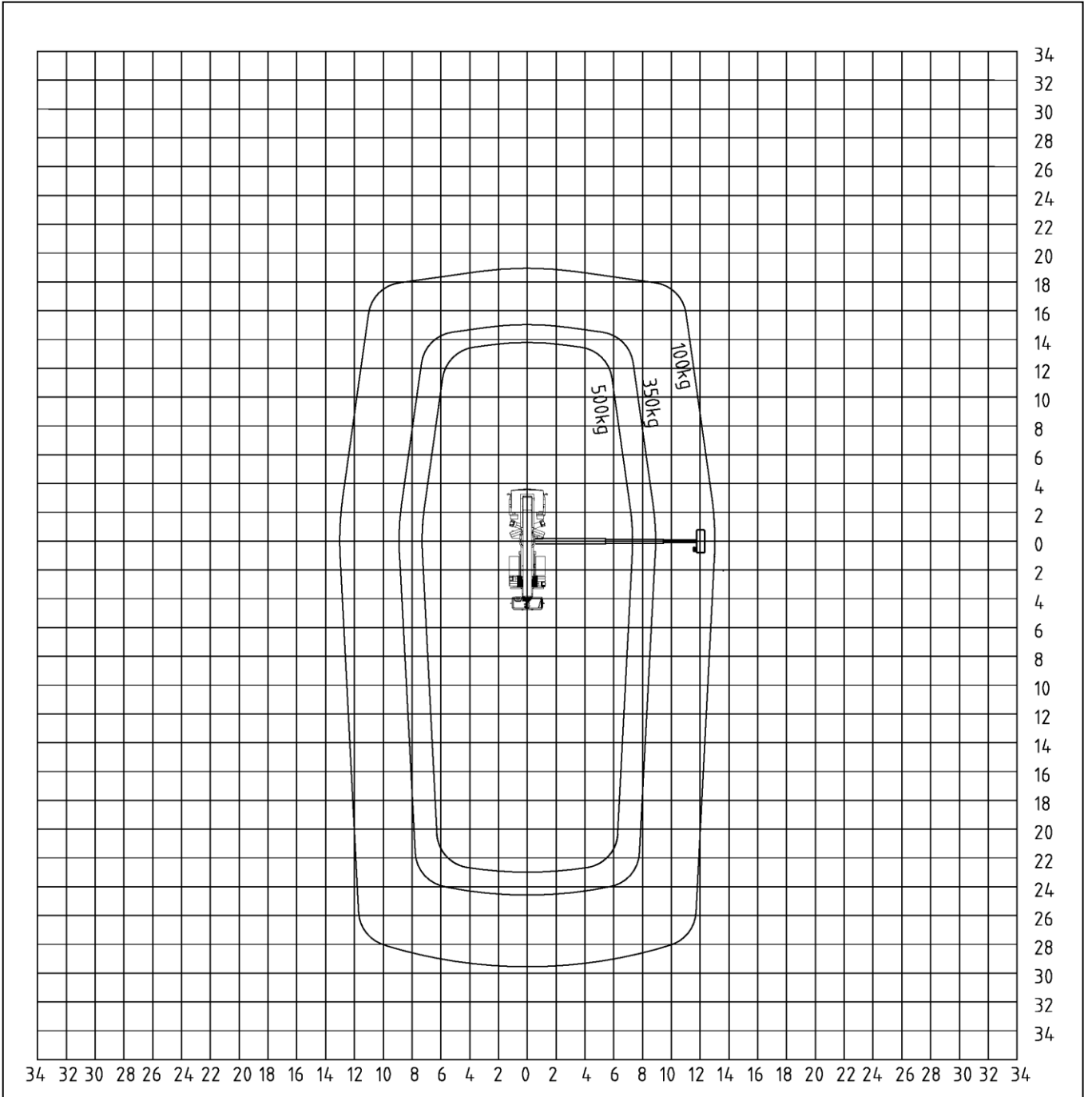

# Palfinger P 370KS

## Left view

Extension of stabiliser  
outrigger

Front left	0%
Front right	0%
Rear left	0%
Rear right	0%

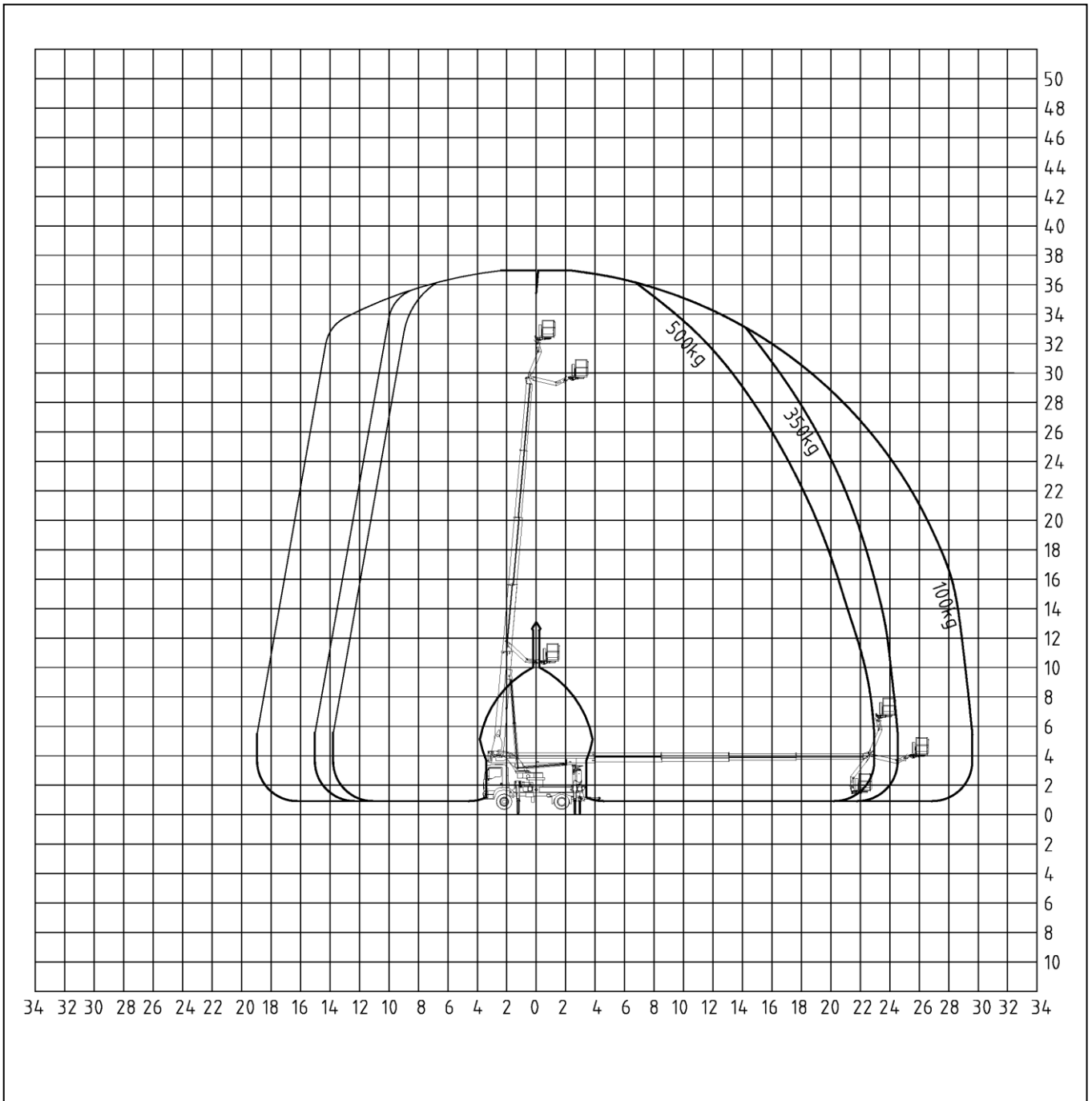

## YOUR REQUESTED SPECIFICATION

P 370 KS - P 370 KS - Palfinger Access Platform

The P 370 KS is agile, versatile, compact and extremely powerful. This platform combines the best of two worlds. It integrates the impressive flexibility of the WT series and the compact design and well-known counter slewing system of the KS series.

FZTYP - FZTYP

0024 - MAN TGM 18.XXX 4x2 Euro6 C-Cab

FAT00312 - Modification MAN TGM 18t 4x2 (P370KS)

- Relocation of chassis components
- Relocation of exhaust system
- Mounting chassis brackets
- Mounting hydraulic pump
- Electrical modification incl. signal provision
- Mounting of display in cab

KWZ00102 - Tool storage tray, 500 mm

Tool storage tray integrated in the cage, 500 mm long

Only available for GRP-cage!

GGK00103 - Tool box and bracket

Plastic tool box and bracket on base

SSG00103 - Protection guard over hydraulic tank

Protection guard over hydraulic tank at arm boom rest

ABW00106 - Bordering 400mm, both sides hinged

Bordering 400mm high, on the platform decking as part of the chassis covering, hinged at right and left hand side with gap between bordering and platform decking

ABW02001 - Attachment point for load securing nets

Attachment point for load securing nets at the bordering

AAL00204 - Ladder to the platform right side  
Access ladder to the platform decking right side

---

SSG00101 - Protection guard on top of driver's cab  
Made of wave grid

---

AHA01003 - Bracket 7 traffic cones (without cones)  
Bracket for 7 traffic cones (without traffic cones)

---

SSR00102 - 2 Covers for warning beacon on turntable  
2 Covers for warning beacon on turntable

---

SSA00102 - Cover for vehicle transmission  
Cover on sub frame to protected the vehicle Transmission.

---

ELW00123 - Flashing light, fixed left on turntable  
Flashing light, yellow, fixed, on the left side at the turntable, Type Comet-B LED

---

ELW00124 - Flashing light, fixed right on turntable  
Flashing light, yellow, fixed, on the right side at the turntable, Type Comet-B LED

---

SSS00102 - Device for checking axle-position  
Device for checking axle-position for both axles, with one sensor per tyre each

---

EDE00501 - Telematic-module  
Telematics module mounted on the Platform and wired ready for operation.  
For use of the extensive applications, a Palfinger Connected software contract must be concluded.

---

DDK00101 - Operating instructions, stickers German  
Operating instructions, stickers, labels and display messages (if display available) in German language

---

DDK00102 - Operating instructions, stickers English  
Operating instructions, stickers, labels and display messages (if display available) in English language

---

DDK00199 - Second set of documentation + stickers  
additional manual, stickers and labels in a second language (please specify the second language)

---

LSS00101 - Warning hatching acc to DIN 30710

Warning hatching at the chassis according to DIN 30710, fixed horizontally at the front side

---

LSS00104 - Application of warning stripes DIN 30710

Application of warning stripes in accordance with DIN 30710, applied in horizontal direction to the driver's and passenger's side of the truck

---

ZAN00201 - DEKRA acc. §21 StVZO 7,5-18t

DEKRA inspection acc. to §21 StVZO.

In order to carry out the inspection the truck's data sheet and/or COC is required! (GVW 7,5t - 18t)

---

EXT-WAR-01

Extended Warranty 12+12 Month

---

—

## EQUIPMENT

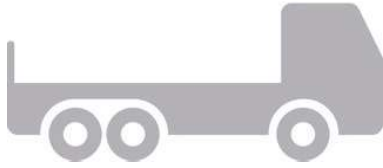

PPG02

MAN TGM 18.290 4x2 BB - Standardconfig.

- Emission class EURO 6D
- Driver's cab CC
- wheelbase 3.875 mm
- Gross weight 18.000 Kg
- 150 l fuel tank, right
- 35 l AdBlue-Tank, right
- Parking brake, on front axle(s), pneumatic, additional, exhaustible
- Diesel engine MAN D0836 LFLAO, 213 kW (290 PS) Leistung,
- 1.150 Nm torque, Euro 6d
- MAN TipMatic 12.12 OD
- Tyres, M+S Label front and rear axle
- Differentiallocks on driver rear axles
- Assisted high-beam headlight
- Exterior rear-view mirror, electrically adjustable with manoeuvring aid
- Mirror housing, not painted
- Kerb mirror, right, electrically adjustable
- Front mirror, mechanical adjustment
- Comfort driver's seat, air-sprung, with lumbar support and shoulder adjustment
- Driver's seat heating
- Air-conditioning system, Climatronic
- MAN mediasystem navigation advanced 7 Zoll
- MAN soundsystem advanced
- Europe and Russia navigation map
- Smartphone integration
- 2 clevis mounted at the rear frame
- Top coating driver's cab: PURE WHITE RAL 9010
- Top coating chassis: GRAPHITE BLACK RAL 9011

# MAN Truck & Bus SE



## Scope of delivery

Basic data		Weights	
Order number:	812969373	Gross weight:	18000 / 18000 / 18000
Vehicle number:	08D0589	1. Front axle:	7100 / 7100 / 7500
Vehicle variant:	TGM 18.290 4x2 BB CH	2. Front axle:	0 / 0 / 0
Basic vehicle:	L08D AA 02	3. Front axle:	0 / 0 / 0
Status:	Ready for delivery	Leading axle:	0 / 0 / 0
Earliest/latest delivery:	09.03.2023 - 09.03.2023	1. Rear axle:	11500 / 11500 / 11500
Change stop:		2. Rear axle:	0 / 0 / 0
MAN Code:	5AAOCTR0	Trailing axle:	0 / 0 / 0
VIN:	WMA08DZZ4PP214236	Hide no-codes:	Yes
Engine number:			

Add/remove	Code	Description
------------	------	-------------

Current scope of delivery

### Vehicle characteristics

#### Basic characteristics

0PI Z7	TG3
0P3MB	MAN
0P3MA	Trucks
0P3MB	NHMR
0P2U9	Chassis
0P2UB	Chassis class, light/medium
0P3GA	Destination: Germany (DE)
0P8LF	Merchant tonnage 18 t
0PGCU	Basic layout of vehicle, all-round
0P2TS	Frame type, normal height
0P2UQ	Vehicle type, platform truck and chassis (LK)
0P3AS	Left-hand-drive
0P3F5	Right-hand traffic
0P2L6	Vehicle documents in German
0P8NL	Labelling in German
0T0AO	Type truck 08D
0P6CU	D08R6N_EURO6_L
0P6FC	LK_CC_3875_1925
0PGDB	CC_LM
0PHBD	Cab position 530 mm (distance from frame lower edge to cab floor)

**Add/remove    Code    Description**

**Registration**

0P3JR	Vehicle approval, N3 class
0P2UJ	Maximum speed limiter, 89 km/h, tolerance +1 km/h, electronic, engine speed regulation
0PJPC	Regulation (EC) 595/2009, Euro VIe (heavy commercial vehicle emissions) fulfilled
0P2YJ	Maximum vehicle noise level, 78 dB in acc. with UN/ECE-R 51.03
0PHA1	Height over cab, unloaded up to 4,000 mm
0PHDB	Swing out of vehicle rear up to 800 mm/1,000 mm with raised or steered last axle
0PKAW	Vehicle classification in accordance with regulation (EU) 2018/858

**Documents**

0P2Q7	European standard exhaust emission confirmation
0P3AZ	Registration documentation, national
0P3CK	Special confirmation, heavy load / municipal operation
0P2E3	L-plate and low-noise acceleration (in acc. with KDV 1967)

**Application scope / transport tasks**

0P6W5	Special applications
0P0UU	Increase of the tyre load capacity by 10% (for communal supplement)
0P2RR	220 Skylifter
0P0G7	Temperate range, vehicle deployment, moderate
0P4F0	Case hardness of final drive Distribution

**Lines, editions and packages**

0PJTD	Special request paintwork
0PJT1	Without Individual Lion package

**Horizontal and vertical loads**

0P5PB	18,000 kg permitted gross load, vertical, nat. appr.
0P5S4	18,000 kg permitted gross load, vertical, tech.
0P8GQ	18,000 kg permitted gross load, vertical, tech. Plus
0P5KQ	7,100 kg permitted load on front axle, nat. appr.
0P5LK	7,100 kg permitted load on front axle, tech.
0P8D1	7,500 kg permitted load on front axle, tech. Plus
0P7C0	7100/0kg load variant, vertical, front axles, national registration
0P7CB	7100/0kg load variant, vertical, front axles, tech.
0P7R0	7500/0kg load variant, vertical, front axles, tech. plus
0P5G7	11,500 kg permitted load on rear axle NatZu
0P5I J	11,500 kg permitted load on rear axle, tech.
0P8BN	11,500 kg permitted load on rear axle, tech. Plus
0P7B1	0/11500/0/0kg load variant, vertical, rear axles, national registration
0P7F1	0/11500/0/0kg load variant, vertical, rear axles, tech.

Add/remove	Code	Description
------------	------	-------------

	0P7J1	0/11500/0/0kg load variant, vertical, rear axles, tech. plus
--	-------	--

	0P9CU	Load key, vertical, 023
--	-------	-------------------------

	0P8XD	0kN D value
--	-------	-------------

	0P9E1	0/0kg load variant, horizontal, assign., national registration
--	-------	--

	0PAPJ	0/0kg load variant, horizontal, assign., tech. hom.
--	-------	---

	0P9TI	0/0kg load var., hor., assign., tech. plus, D-value=0kN, without gradeability restrictions
--	-------	--

	0P9BI	Load key, horizontal, 021
--	-------	---------------------------

**Notification texts**

	0PJRV	Without note (propshaft wear)
--	-------	-------------------------------

**Scopes for adaptation for military use**

**Chassis**

**Vehicle frame (wheelbase, overhang, ...)**

	0P2ZJ	Main wheelbase, 3,875 mm
--	-------	--------------------------

	0P3DG	Frame overhang, rear, 1,925 mm
--	-------	--------------------------------

	0P0Y5	Main frame side member thickness, 7 mm
--	-------	--

	0P0XT	Vehicle rear, straight end of frame
--	-------	-------------------------------------

**Exhaust system, air intake**

	0P1BI	Exhaust silencer, side, right, offset to the rear
--	-------	---

	0P1BT	Exhaust tailpipe, towards middle of frame
--	-------	---

	0P0AY	Air intake, behind cab, raised
--	-------	--------------------------------

	0PHCV	Exhaust silencer cover (styling)
--	-------	----------------------------------

**Battery cases, batteries, alternator**

	0PHLB	2 batteries, 12 V, 150 Ah, standard (SLI), maintenance free
--	-------	---

	0P1BZ	Three-phase alternator 28 V, 120 A, 3,360 W, LIN
--	-------	--

	0P0VS	Small battery box, 2 batteries
--	-------	--------------------------------

	0P0WD	Battery box, left
--	-------	-------------------

	0P0WF	Main battery switch, mechanical
--	-------	---------------------------------

	0P1V1	Fuses
--	-------	-------

	0P0W	Battery cable extension, 6 m
--	------	------------------------------

	0P0WK	Lockable battery box, without padlock
--	-------	---------------------------------------

**Tanks and fuel line**

	0P4DZ	Fuel tank capacity 150 l, right
--	-------	---------------------------------

	0P4GN	Fuel tank, right, steel
--	-------	-------------------------

	0P4HF	Tank cross-section, right, low
--	-------	--------------------------------

	0P4HA	Tanks, right, lower position
--	-------	------------------------------

	0P4CZ	AdBlue tank capacity 35 l, right
--	-------	----------------------------------

	0P4HU	AdBlue tank, right, plastic
--	-------	-----------------------------

Add/remove	Code	Description
------------	------	-------------

	0P4H5	Fuel tank cap, lockable for master key system
--	-------	---

	0P4GE	Cap for AdBlue tank, lockable
--	-------	-------------------------------

	0PKN2	Fuel pre-filter on the frame
--	-------	------------------------------

**Frame attachments**

	0P1FN	Underride protection, front
--	-------	-----------------------------

	0P0VH	Without working platform
--	-------	--------------------------

	0P1FG	Without underride protection, side
--	-------	------------------------------------

	0PJR1	Final cross member, with hole pattern 83 x 56 mm
--	-------	--

	0P1FB	Without underride protection, rear
--	-------	------------------------------------

	0P1FO	Wheel chock, 1 unit, with retaining device
--	-------	--

	0P0X4	Loose body attachment bracket
--	-------	-------------------------------

**Pneumatic brakes, compressed-air generation, brake system**

	0P4Y2	Air compressor, single cylinder, 238 ccm, with economy system
--	-------	---

	0P0B2	Air dryer, heated
--	-------	-------------------

	0P0AB	Compressed-air treatment, pneumatically controlled
--	-------	--

	0P0XH	Steel compressed-air tank
--	-------	---------------------------

	0P0BL	Electronic brake system (EBS)
--	-------	-------------------------------

	0P0BE	Anti-lock braking system (ABS)
--	-------	--------------------------------

	0P0CM	Full brake assistant
--	-------	----------------------

	0PHPM	Without preparation for EBS Full control unit
--	-------	---

	0P0BU	Engine brake, exhaust flap
--	-------	----------------------------

	0P1I 9	Disc brakes on front axle
--	--------	---------------------------

	0P1I 4	Disc brakes on rear axle
--	--------	--------------------------

	0P3KG	Parking brake control, in instrument panel
--	-------	--

	0PGBL	Parking brake with spring-type actuator on rear axles (incl. leading axle/ trailing axle)
--	-------	---

	0P0C1	Parking brake, on front axle(s), pneumatic, additional, exhaustible
--	-------	---

	0P1TF	MAN EasyStart immobiliser
--	-------	---------------------------

	0P0BG	Brake lining thickness display, with brake lining wear warning
--	-------	--

	0P0BI	Harmonisation of brake lining wear
--	-------	------------------------------------

**Lights and acoustic signals on the chassis (rear lights, ...)**

	0P2AQ	Rear lights
--	-------	-------------

	0P0CG	Emergency braking signal, hazard light activation, automatic
--	-------	--

	0P3CE	Acoust. Reversing warning system deactivatable when reverse gear selected
--	-------	---

	0P2AD	Light function test
--	-------	---------------------

	0P2BJ	Side marker lights, LED
--	-------	-------------------------

**Driveline/running gear**

**Engine, radiator**

Add/remove	Code	Description
	0PI AJ	Diesel engine MAN D0836 LFLBJ, 213 kW (290 hp) output, 1,150 Nm torque, Euro 6e
	0PHZN	Engine, with on-board diagnosis, OBD-E
	0PHI F	Fuel filter, heated, for fuels up to Cleanliness Class 21
	0P4XP	Fuel pre-filter, with oil separator/water trap, with water sensor, heated
	0P8PM	Ventilation, crankcase, closed
	0P2E7	Anti-noise skirt, engine
	0P4XX	Engine cooler, normal length
	0P0B6	Engine oil dipstick and digital oil level gauge
	0P0AK	Antifreeze, down to -32 °C
	0P0GD	Flame-start system
	0PGCM	Stationary regeneration for catalytic converter, executable at any time, for light loads
	<b>Gearbox, clutch</b>	
	0P5VP	MAN TipMatic 12.12 OD
	0PGDA	Gearbox for normal percentage of overrun during driving operation
	0P3KI	MAN TipMatic actuation, with drop arm, manual (DNR option, switching strategy option)
	0P0ER	MAN Idle Speed Driving gearbox function
	0P0FA	MAN TipMatic Efficiency driving program, up to 70,000 kg
	0P0DS	Single-disc clutch, 395 mm, dry
	<b>Wheels, tyres</b>	
	0PFVØ	Required tyre speed index J
	0PHWD	Tyres front axle Continental 295/80R22.5 CROSS TRAC HS3 Steering-S+G TL
	0P0P0	Rim type, front axle, steel, single-part
	0P0NI	Rim size, front axle, 10-hole, 9.00x22.5
	0P0PR	Wheel nut cover ring, front axle
	0PJDB	Tyres, rear axle, Continental 295/80R22.5 CONTI ECOREGIONAL HD3 Drive-Local TL
	0PJBH	Tyre tread CONTI ECOREGIONAL HD3, rear axle
	0P0OO	Rim type, rear axle, steel, single-part
	0P0MQ	Rim size, rear axle, 10-hole, 8.25x22.5
	<b>Axles</b>	
	0P3B1	4x2
	0P1JX	Steering ratio, standard
	0P1JW	Steering oil tank with dipstick
	0P5EQ	Front axle, 7,500 kg, not driven, cranked, steered, not liftable
	0P1AT	Mudguard, front axle
	0P1XS	Splash guard mat on mudguard, front axle, longer at bottom
	0P4ZL	Rear axle, 11,500 kg, HY axle without drive shaft, straight, not steered, not liftable
	0P1HN	Twin tyre on rear axle

**Add/remove    Code            Description**

0P1AI	Mudguard, rear axle
0P1XK	Splash guard mat on mudguard, rear axle, longer at bottom
0P0D9	Axle ratio, i = 4.63
0P0DI	Differential locks on driven rear axles
0P0DL	Without differential locks, front axles
<b>Axle control system and suspension</b>	
0P2YB	Suspension type for front axles and driven rear axles, leaf/leaf (BB)
0P1JC	Leaf-spring suspension on front axle, parabolic, 1-leaf, steel
0PGBF	Leaf-spring suspension on rear axle, parabolic, 4-leaf, steel
0P5CZ	Spring load-bearing capacity front axle 7,500 kg
0P5BT	Spring load-bearing capacity of rear axle, 11,500 kg
0P1M4	Shock absorbers on front axle
0P1LQ	Shock absorbers on rear axle
0P1LD	Stabiliser, front axle
0P1LA	Stabiliser, rear axle
0P6ZY	Axle location system not as wishbone

**Cab**

**Cab and cab exterior**

0P2DK	Compact CC cab
0P1V8	Cab mount, Basic
0P1V6	Cab tilt mechanism, manual
0P1VY	No tilting roof/sliding roof
0P1SD	Bumper, plastic
0P1VE	Front step, integrated, with grab option
0P1X0	Windscreen, composite safety glass, tinted
0P1WJ	No sunblind, in front of windscreen
0P1WG	Wiper system for windscreen
0P1UM	Wiper activation, automatic, with rain sensor (automatic wipers)
0P1UZ	Step unit, rigid
0P1WR	Central locking, with remote control
0P3JU	Vehicle key, 4 units
0P1WW	No door extension
0P2DQ	Door labelling, according to trade tonnage of vehicle
0P1W0	Door windows, tinted
0P1WM	Door window, safety glass
0P1VB	Cab rear wall, with window

**Lights and acoustic signals on cab exterior (headlights, horn, ...)**

Add/remove	Code	Description
------------	------	-------------

	0P1ZN	Front headlights, H7
	0P2BQ	Daytime driving lights with rear lights, LED
	0P2AH	Fog lights, H7
	0P1Z6	Turn signal lights, sides, bulb
	0P2AC	Headlight beam regulator, manual
	0P1ZH	Assisted high-beam headlight
	0P1ZE	Driving-light control, automatic, with light sensor
	0P2BT	Contour lights, bulb, 2 units
	0P1ZW	Comfort indicator function, can be activated
	0P1W	Horn, two-tone, electrical
	0P1YK	Spotlight, 1 unit, cab roof, left
	0PJQA	Spotlight, LED, white
	0P5U5	Switch for spotlight/manoeuvring light
	0P2A5	Preparation for loading area lighting
	0PJRO	Without revolving beacons at the rear of the vehicle
	<b>Mirrors and mirror replacements</b>	
	0P2CB	Exterior rear-view mirror, electrically adjustable with manoeuvring aid
	0P2CG	Kerb mirror, right, electrically adjustable
	0P2CJ	Front mirror, mechanical adjustment
	0P2CP	Mirror housing, not painted
	0P2CT	Vehicle components, suitable for body width larger than 2,400 mm to 2,600 mm
	0P2D3	Preparation for rear-view camera, 2 units, one camera linked to reverse gear
	<b>Seats</b>	
	0P2PQ	Seat covers, fabric, standard
	0P2P5	Comfort driver's seat, air-sprung, with lumbar support and shoulder adjustment
	0P2PX	Driver's seat heating
	0P2OE	Driver's seat arm rests
	0P4XQ	Adjustment of seat belt height, driver's seat
	0P2OO	Co-driver's seat, not sprung, with storage box
	0P2G6	Storage space, in seat bracket of co-driver's seat
	0P8L1	Indicator, seat belt, 1st row of seats, acoustic and visual
	<b>Driver's workplace</b>	
	0P2GD	Multi-function steering wheel, adjustable height and angle
	0P2GE	Steering wheel, with parking position
	0P3K0	Steering lock, with electronic immobiliser
	0P3L3	Instrumentation, Basic km/h
	0P5DV	Tachograph, digital, with telecommunication (as per DSRC), CONTINENTAL

Add/remove	Code	Description
------------	------	-------------

	0P2KG	Tachograph, calibrated
--	-------	------------------------

	0P2JJ	Remote download for digital tachographs
--	-------	---

	0P2MF	Preparation for Toll Collect toll recording system
--	-------	--

	0P2MA	Driving hours indicator, instrumentation
--	-------	--

	0P2HX	Socket, cab centre, 2 units, 12 V and 24 V
--	-------	--

	0P2FO	Plug-in ashtray, instrument panel in middle section, 1 unit
--	-------	---

	0P2I H	Cigarette lighter
--	--------	-------------------

	0P3KE	Standard control field, inside of driver's door, with door open operated externally, 4 function buttons
--	-------	---

	0P2FJ	Single DIN slots, 4 units, roof space, front
--	-------	--

**Cab air-conditioning system**

	0P2NT	Air-conditioning system, Climatronic
--	-------	--------------------------------------

**Bunk area**

	0PKNE	Without bunk area package
--	-------	---------------------------

**Cab interior**

	0P2I 6	Colour scheme for interior styling, dark
--	--------	--

	0PGBT	Interior styling analogous to colour scheme
--	-------	---

	0P2FE	Windscreen roller blind, internal
--	-------	-----------------------------------

	0PKNF	Without interior lighting package
--	-------	-----------------------------------

	0PHA6	Interior light, central
--	-------	-------------------------

	0P2I R	Reading light, 2 units, 1 on driver's side and 1 on co-driver's side
--	--------	--

	0P2I O	Entry lighting
--	--------	----------------

	0PHPK	Entry handles, standard
--	-------	-------------------------

	0P2I A	Door interior cladding, washable
--	--------	----------------------------------

	0P2EZ	Stowage compartment, 2 units, cab rear wall, driver's side and centre
--	-------	---

	0P2G2	Grab handle, above door, internal, 2 units, 1 right and 1 left
--	-------	--

**Accessories and tools**

	0P2TX	Vehicle toolkit
--	-------	-----------------

	0P3F3	First aid kit
--	-------	---------------

	0P3FI	Warning triangle, 1 units
--	-------	---------------------------

	0P3FF	Hazard warning light, 1 units, with continuous light function
--	-------	---

	0P3F6	No jack
--	-------	---------

**Intelligent Truck**

**Assistance systems**

	0P1TN	Electronic Stability Program (ESP)
--	-------	------------------------------------

	0P1T2	Anti-slip control (ASR)
--	-------	-------------------------

	0P1TR	Tempomat (cruise control, CC)
--	-------	-------------------------------

	0P0C3	Road speed limiter, adjustable, limiter (engine speed regulation)
--	-------	---

Add/remove	Code	Description
------------	------	-------------

	0P1U3	Advanced Emergency Brake Assist (EBA)
--	-------	---------------------------------------

	0P1TT	Lane Guard System (LGS)
--	-------	-------------------------

**Infotainment (radio,...)**

	0P2M0	MMT infotainment system, Advanced Mid
--	-------	---------------------------------------

	0P2MG	MAN sound system
--	-------	------------------

	0P2MK	Europe and Russia navigation map
--	-------	----------------------------------

	0P2N4	Online traffic for navigation function
--	-------	--

	0P2M0	Connectivity Board module
--	-------	---------------------------

	0P2NE	Smartphone integration
--	-------	------------------------

	0P2MC	MAN app integration
--	-------	---------------------

	0P2JQ	English additionally for display
--	-------	----------------------------------

**Bodies/interfaces**

**Interfaces to semitrailer (e.g. fifth-wheel coupling, brake connection,..)**

	0P103	Without trailer brake connection behind cab
--	-------	---

	0P1RJ	No fifth-wheel coupling
--	-------	-------------------------

**Interfaces to trailer (e.g. trailer coupling, brake connections,..)**

	0P1NQ	Without trailer/towing coupling on final cross member
--	-------	---

	0P100	Without trailer brake connection at end of frame, centre
--	-------	--

	0P10W	Without trailer socket at frame end
--	-------	-------------------------------------

	0P109	Without trailer socket for anti-lock brake system (ABS)
--	-------	---

**Ex works bodies and interfaces to bodies (e.g. tipper indicator...)**

	0P2NA	Interface for data exch. with body (customer-specific control module) and engine intermediate speed control (ZDR), front area of cab
--	-------	--

	0P2J3	Interface for vehicle data (FMS)
--	-------	----------------------------------

**Attachments and interfaces to attachments (e.g. silo compressor, front mounting)**

**PTOs**

	0P4PY	PTO, gearbox-dependent, type NH/1b, with flange, f=1.22, position approx. 3:00 o'clock
--	-------	--

	0P4VJ	PTO, gearbox-dependent, continuous operation
--	-------	--

	0P4X9	PTO, gearbox-dependent, shiftable
--	-------	-----------------------------------

	0P4VR	Without fan wheel for PTO, gearbox-dependent
--	-------	--

	0P4W0	Function parameters for PTO, gearbox-dependent, stationary operation
--	-------	--

	0P4VU	Gearbox shift blocking for PTO operation, electric/electronic
--	-------	---

	0P4X0	Sector-specific parameterisation, general
--	-------	---

**Towing, recovery and lashing**

	0P1MK	Central coupling jaw, integrated in bumper/front cross member, with lock pin
--	-------	--

	0P1S2	Shackles, 2 units, end of frame
--	-------	---------------------------------

**Paintworks**

**Paintwork, cab, top**

Add/remove	Code	Description
------------	------	-------------

	0P6YB	Top coating, cab
--	-------	------------------

**Paintwork, cab, bottom**

	0P6X9	Textured coating, step units
--	-------	------------------------------

	0P6YG	Textured coating, mudguard, behind cab
--	-------	--

	0P6YP	Textured coating, bumper, plastic
--	-------	-----------------------------------

**Paintwork, chassis**

	0P6YC	Top coating, chassis
--	-------	----------------------

	0P6YL	Top coating, rims, steel, white-aluminium
--	-------	---

**Paintwork, body**

**Nationale Baugruppe**

**Nationale Subbaugruppe**

	DE02G	Serienmäßige Garantie
--	-------	-----------------------

	DE04A	1 MAN Fahrerjacke, reflektierend (Damen/Herren)
--	-------	---

	DE19A	Servicebetrieb: Einweisung im Service nach Aufbaufertigstellung
--	-------	---

	DE1TR	Transportpauschale Leichte Reihe
--	-------	----------------------------------

	DE3DT	DTCO personalisieren - Eingabe der Halterdaten, amtl. Kennzeichen
--	-------	---

**Wheel**

**Front axle**

		Tyres front axle Continental 295/80R22.5 CROSS TRAC HS3 Steering-S+G TL Rim type, front axle, steel, single-part Rim size, front axle, 10-hole, 9.00x22.5
--	--	---

**Rear axle**

		Tyres, rear axle, Continental 295/80R22.5 CONTI ECOREGIONAL HD3 Drive-Local TL Rim type, rear axle, steel, single-part Rim size, rear axle, 10-hole, 8.25x22.5
--	--	--

**Colour**

**chassis**

		GRAPHITE BLACK RAL 9011 - Water
--	--	---------------------------------

**cab**

		PURE WHITE RAL 9010 - Normal
--	--	------------------------------

