

MAN

P 370 KS

MAN TGM 18.290 4X2 BB

NY

I PRODUKTION



TILBUDSINFORMATION

Lokationsdetaljer

Modena, 41122 - Italien 

Forhandler, detaljer

Palfinger SRL

Tilgængelig fra

31.05.2026

Produkttype

Ny

Kontaktperson

Palfinger SRL

Forhandler, e-mail

info@palfingerplatformsitaly.it

Forhandler, telefon

059252426

Producent	PALFINGER	Søjlerotation	500°
Model	P 370 KS	Kurvestørrelse	2,00 x 0,80 x 1,10 m
Produktionsår	2026	Kurvens kapacitet	500 kg
Rækkevidde	31,5 m	Basket arm angle	185°
Maks. arbejdshøjde	37,0 m	Kurvemateriale	Aluminium
Lastbilproducent	MAN	Hestekræfter	213 kW / 290 PS
Vehicle type	TGM 18.290	Emissionsnorm	Euro 6
Førerhus	C	Aksler	4x2
Akselafstand	4.425 mm	Totalvægt	18.000 kg

Working diagrams

Palfinger P 370KS

on

MAN 18.XXX 16t

The working diagrams shown below have the following preconditions:

Solid line:

Standard working diagram

Working height = height of basket bottom + 2.0 m

The basket is in basic position (not turned) and retracted

The following applies generally:

All specifications refer to standard aluminum basket without additional equipment

Maximum inclination 0,5°

Set-up inclination is max. 2° with automatic range adjustment.

Note on working diagram:

Additional attachments that deviate from the standard reduce range and basket load

Special baskets have different ranges

Reach at plastic workman basket ~ 0,8m reduced

Permitted maximum basket load according to technical description

The outreaches are approximate dimensions and depend on the chassis, the type of support and the lifting platform's additional equipment.

Illustrations of truck and unit are only of symbolic nature and do not allow any conclusions regarding technical design.

Subject to technical change!

Palfinger P 370KS

Rear view

Extension of stabiliser
outrigger

Front left	100%
Front right	100%
Rear left	100%
Rear right	100%

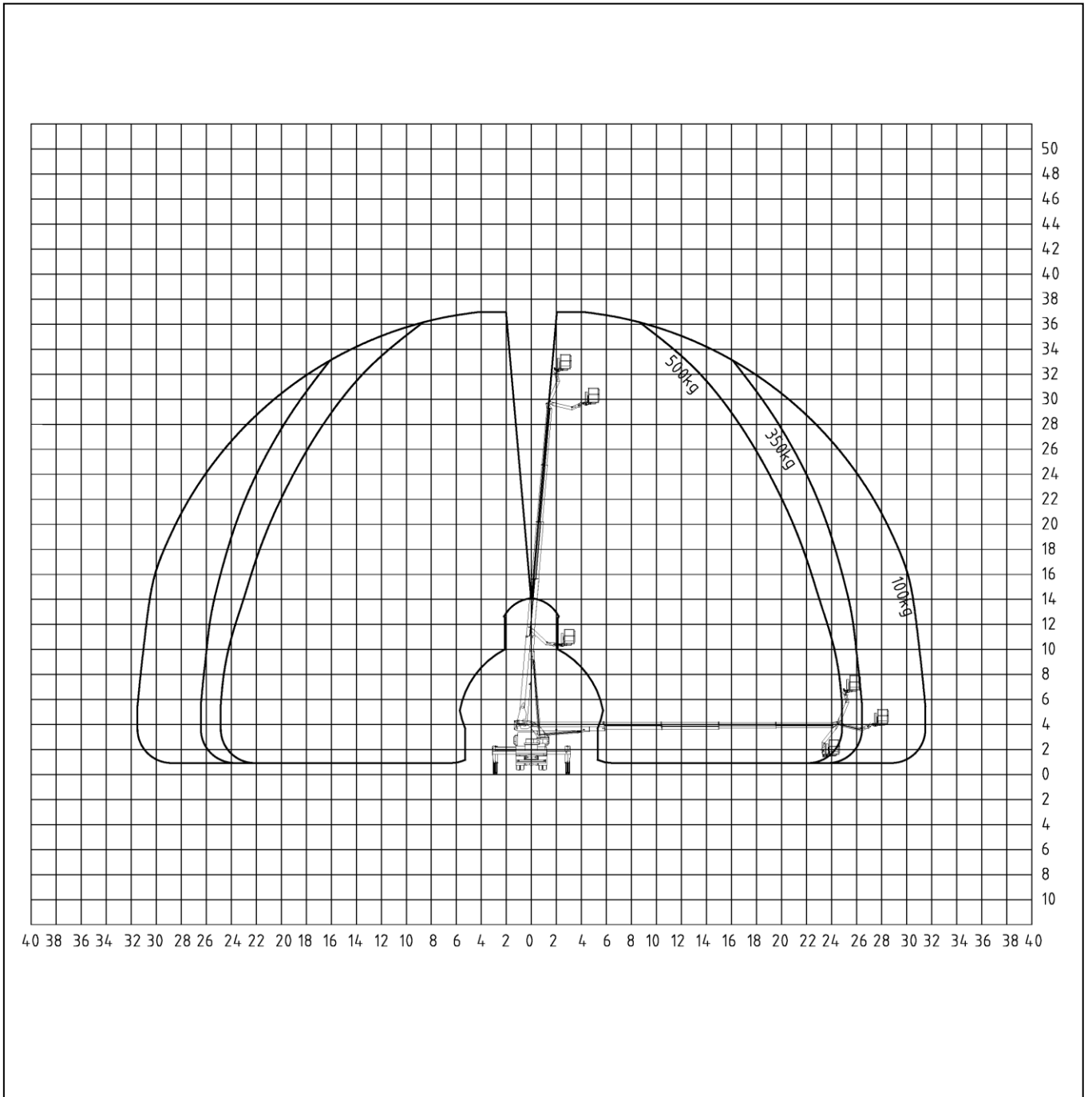

Palfinger P 370KS

Top view

Extension of stabiliser
outrigger

Front left	100%
Front right	100%
Rear left	100%
Rear right	100%

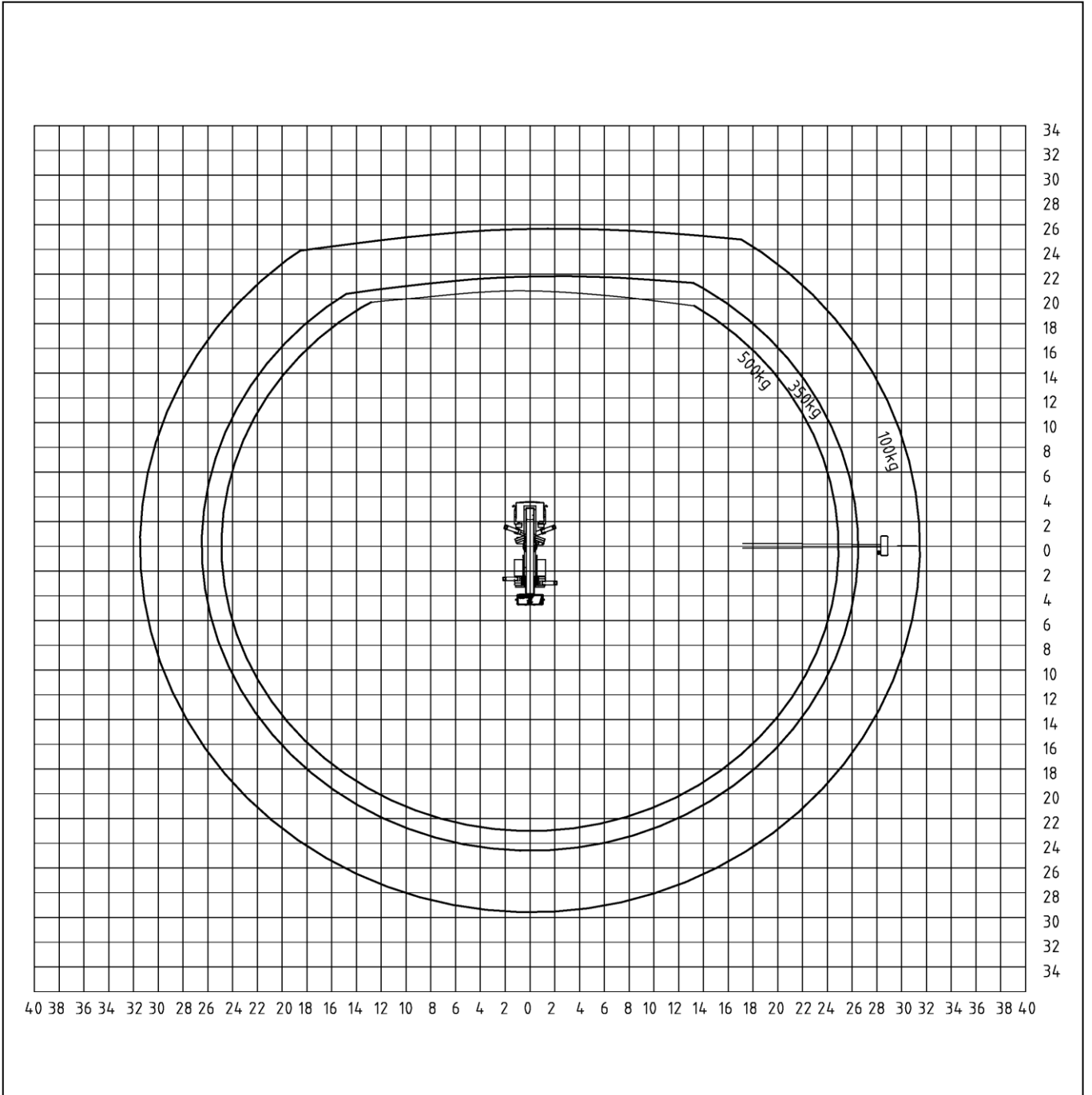

Palfinger P 370KS

Left view

Extension of stabiliser
outrigger

Front left	100%
Front right	100%
Rear left	100%
Rear right	100%

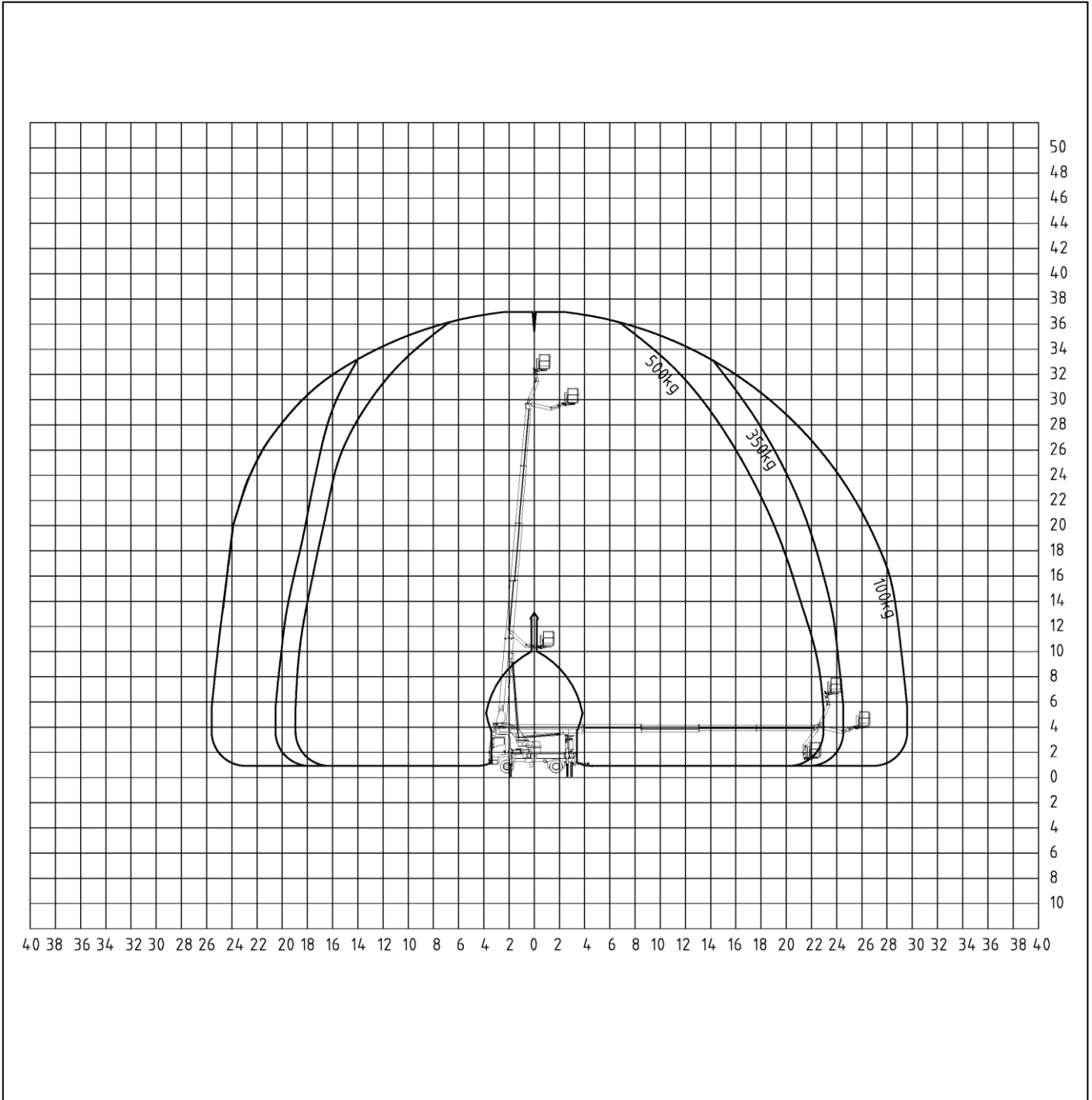

Palfinger P 370KS

Rear view

Extension of stabiliser
outrigger

Front left	50%
Front right	50%
Rear left	50%
Rear right	50%

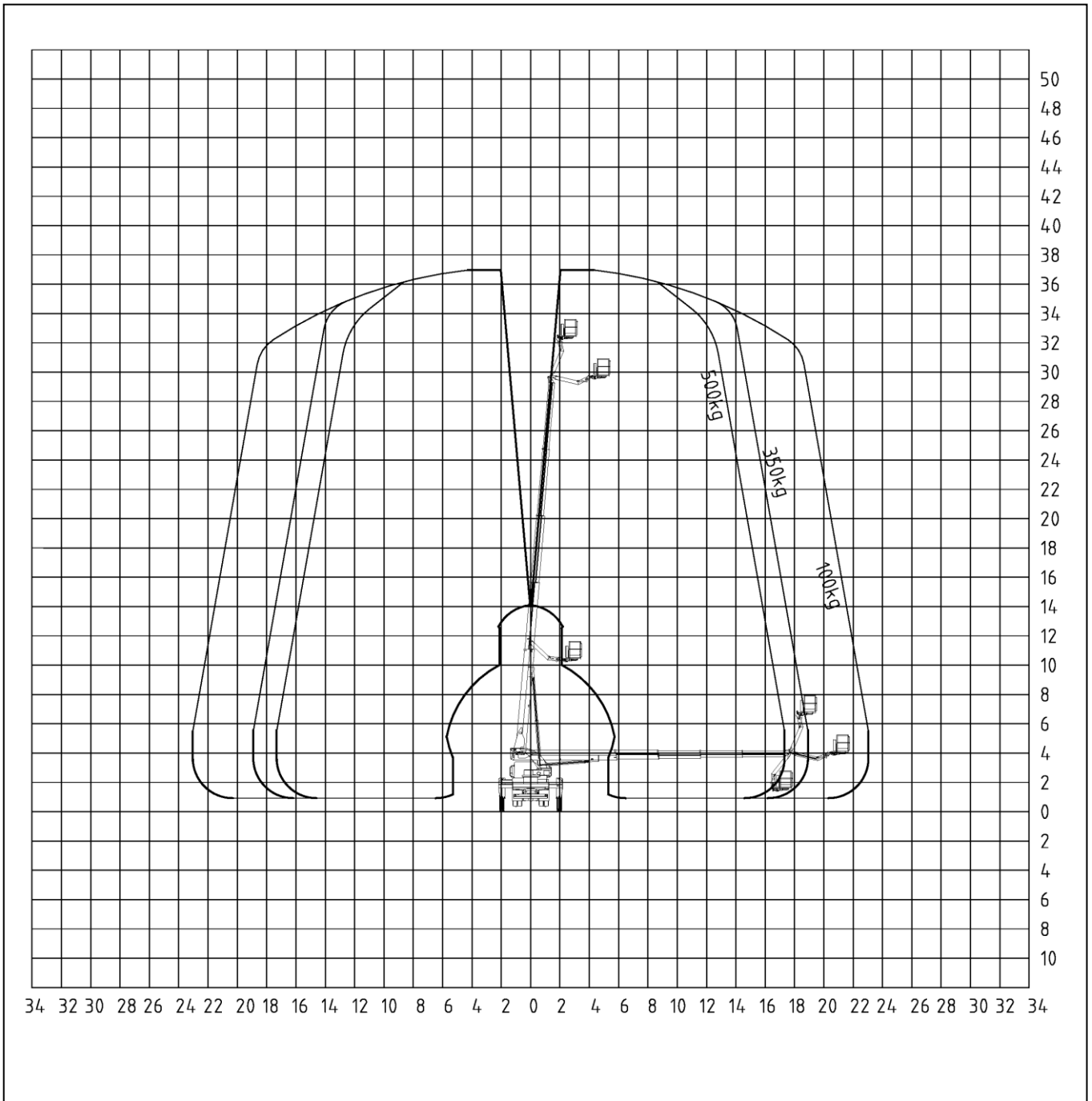

Palfinger P 370KS

Top view

Extension of stabiliser
outrigger

- Front left 50%
- Front right 50%
- Rear left 50%
- Rear right 50%

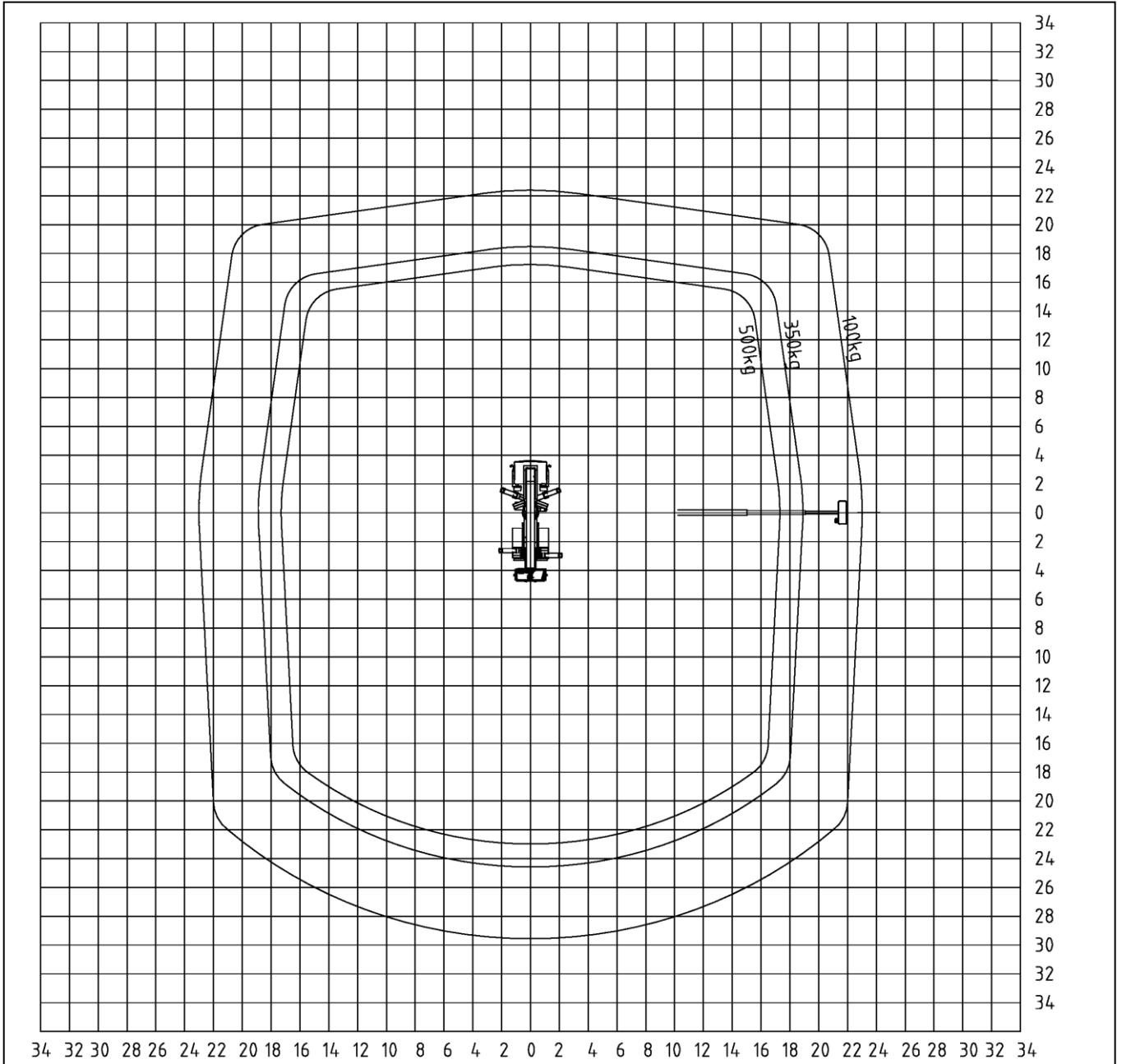

Palfinger P 370KS

Left view

Extension of stabiliser
outrigger

Front left	50%
Front right	50%
Rear left	50%
Rear right	50%

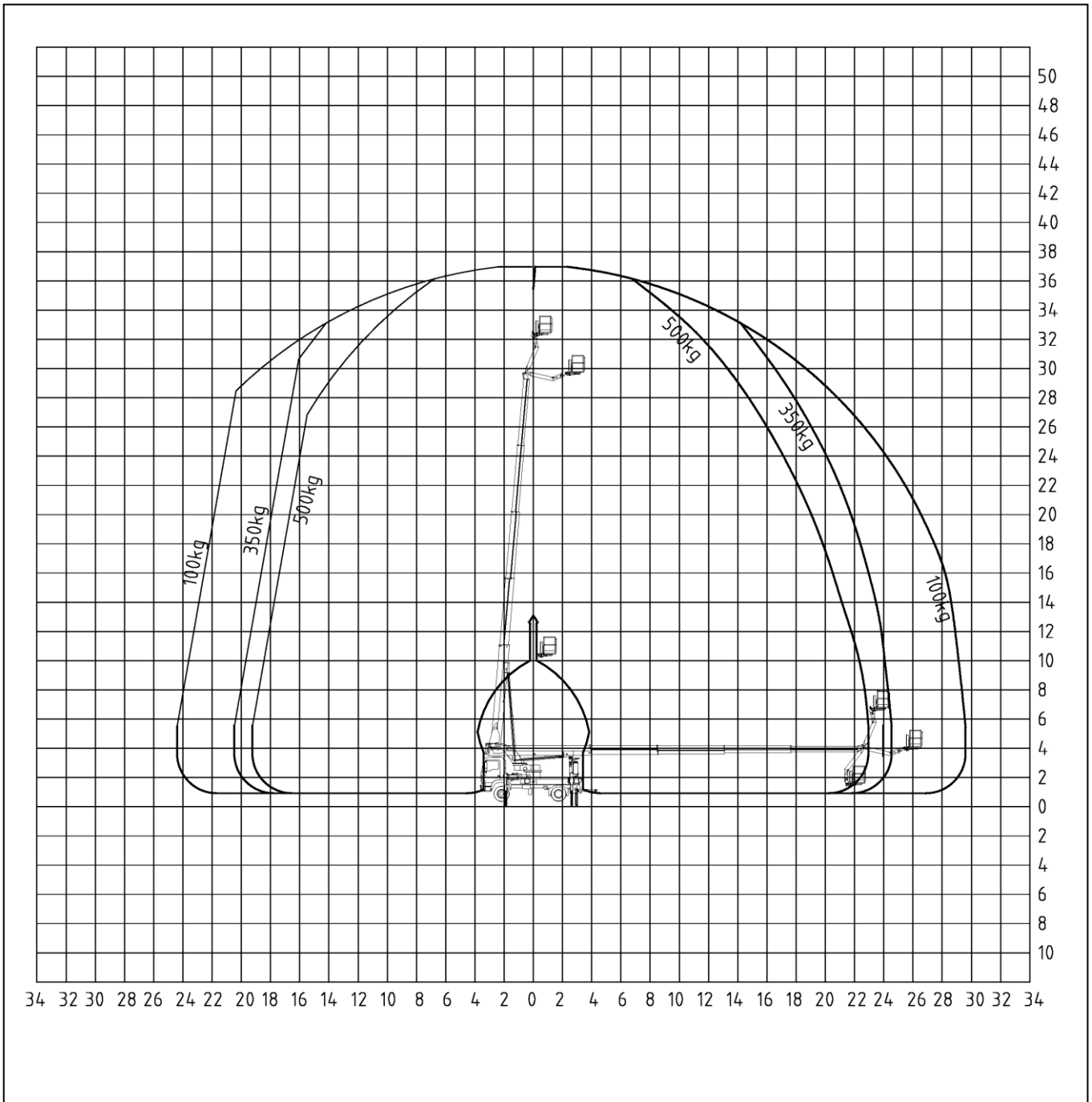

Palfinger P 370KS

Rear view

Extension of stabiliser
outrigger

Front left	0%
Front right	0%
Rear left	0%
Rear right	0%

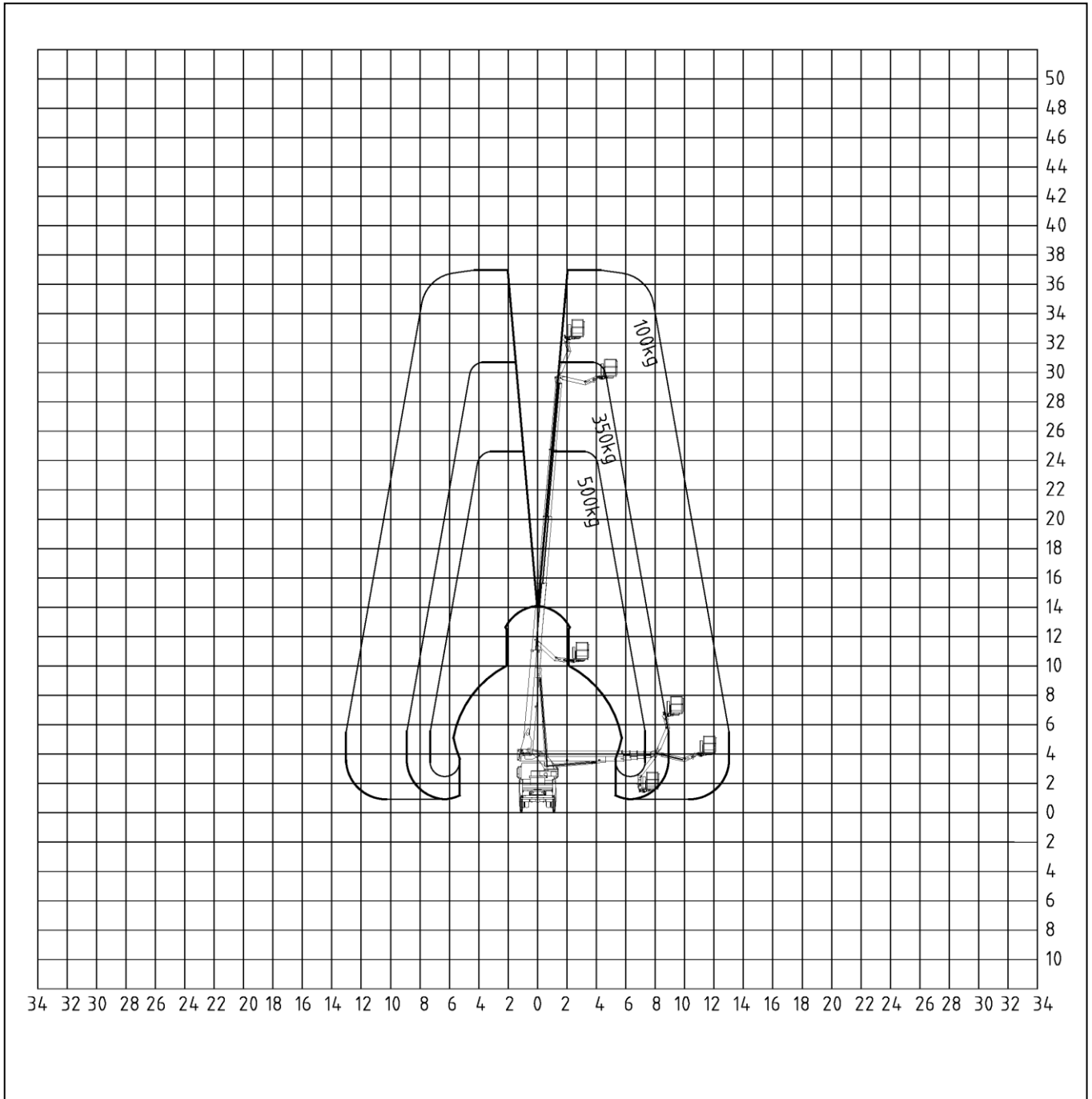

Palfinger P 370KS

Top view

Extension of stabiliser
outrigger

Front left	0%
Front right	0%
Rear left	0%
Rear right	0%

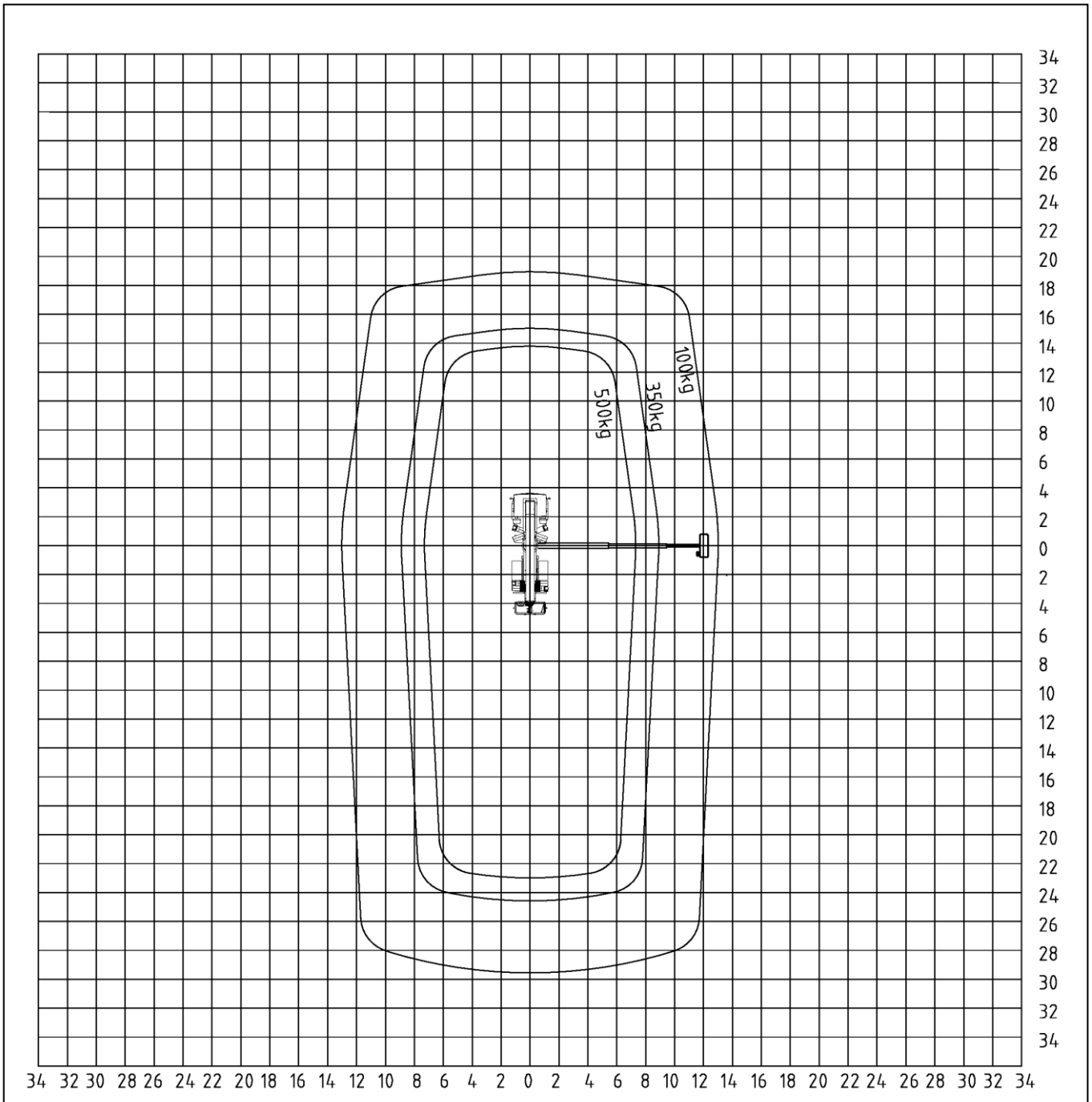

Palfinger P 370KS

Left view

Extension of stabiliser
outrigger

Front left	0%
Front right	0%
Rear left	0%
Rear right	0%

